



# YOUR **TOTAL SOLUTION** FOR **READING**

PRE  
**K**

Practice Activities for Reading Success!



- Kindergarten Readiness Guide
- Colors and Shapes
- Basic Concepts
- Early Writing Skills
- Letters and Sounds



Name \_\_\_\_\_

ALPHABET LETTERS AND SOUNDS

Letter Bb

Directions: Trace and write the letter Bb.



# YOUR **TOTAL** **SOLUTION** FOR **READING**

PRE  
**K**



An imprint of Carson-Dellosa Publishing LLC  
P.O. Box 35665  
Greensboro, NC 27425 USA

Carson-Dellosa Publishing LLC  
P.O. Box 35665  
Greensboro, NC 27425 USA

© 2014 Carson-Dellosa Publishing LLC. Except as permitted under the United States Copyright Act, no part of this publication may be reproduced, stored, or distributed in any form or by any means (mechanically, electronically, recording, etc.) without the prior written consent of Carson-Dellosa Publishing LLC.

ISBN 978-1-4838-1164-2



# Table of Contents

Colors . . . . .	4
Shapes . . . . .	22
Sizes . . . . .	32
Opposites . . . . .	38
Classifying . . . . .	48
Same and Different . . . . .	54
Left to Right . . . . .	64
Top to Bottom . . . . .	70
Lines and Circles . . . . .	76
Alphabet Letters and Sounds . . . . .	84
Review Letters A–Z . . . . .	188
Reading Comprehension Skills . . . . .	194
Critical Thinking . . . . .	207
Kindergarten Readiness Guide . . . . .	214
Answer Key . . . . .	222

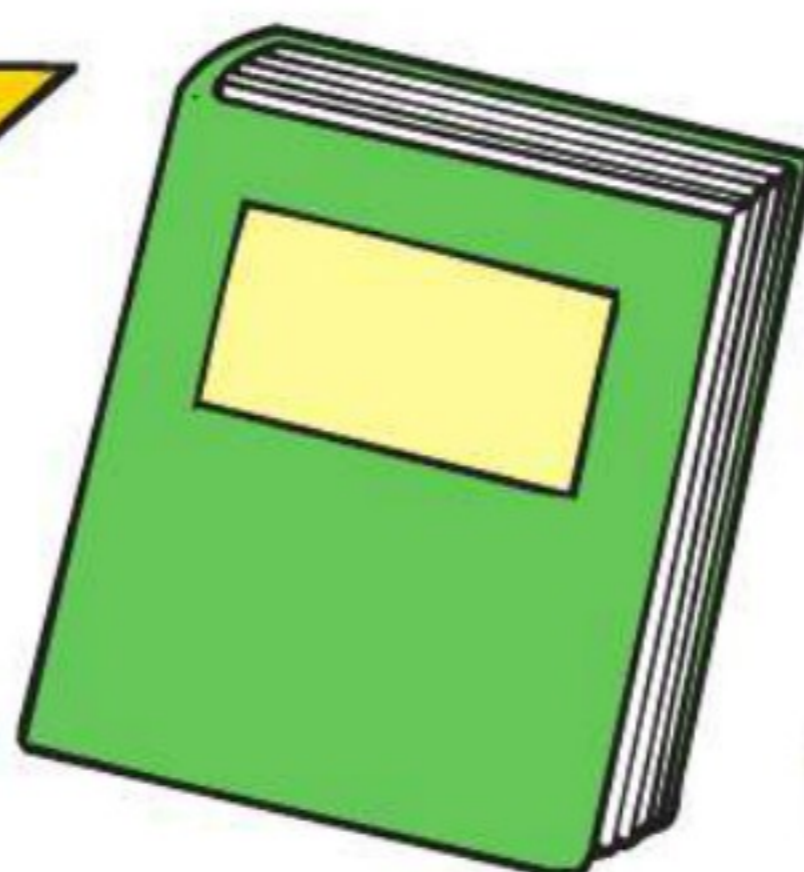
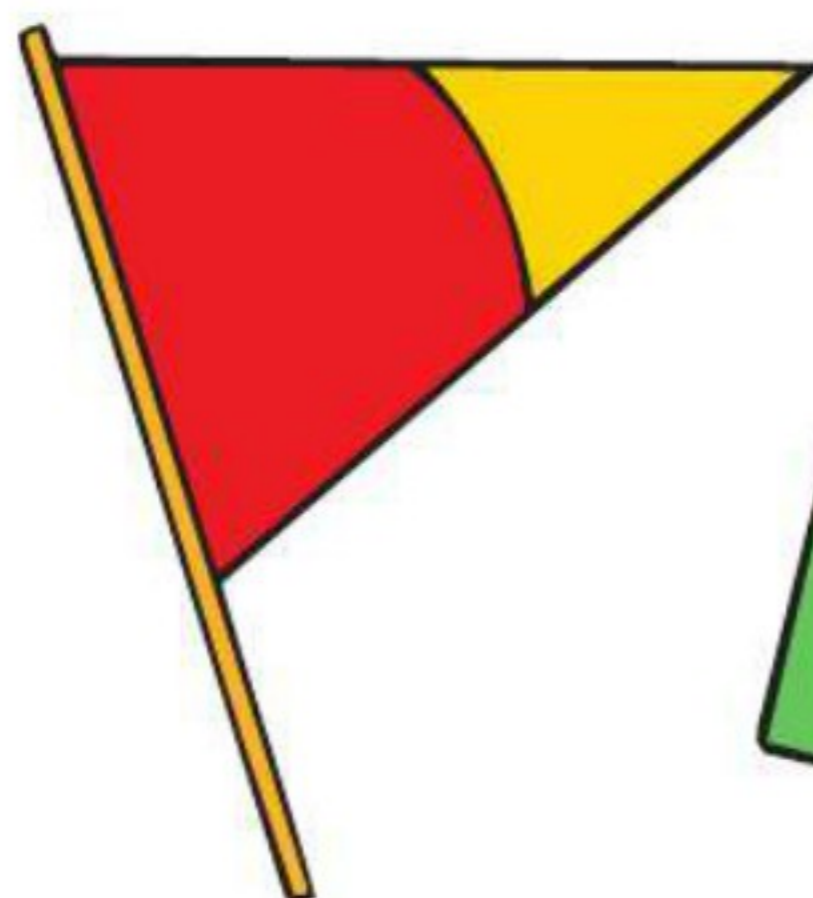
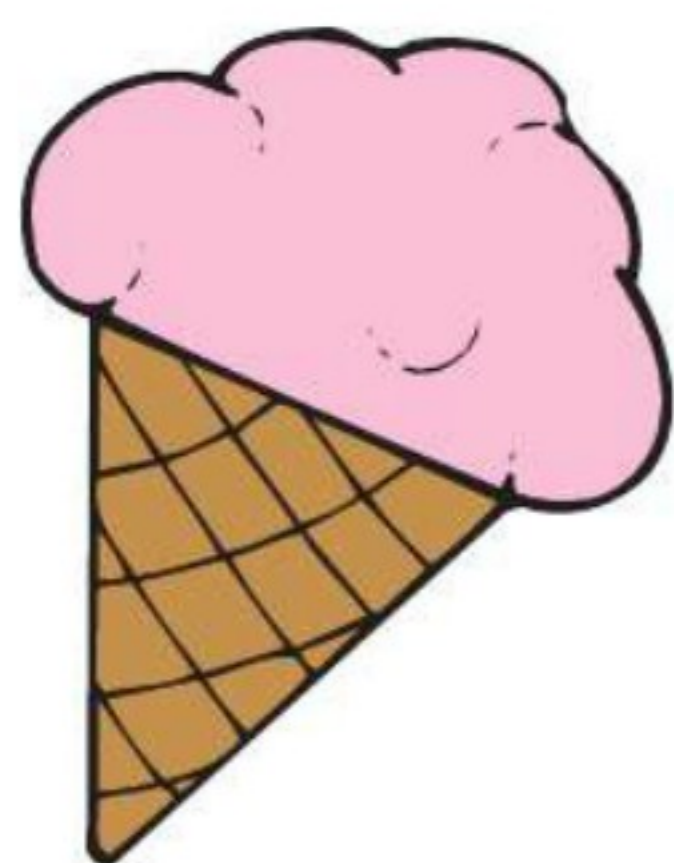



# Color Red Things

**Directions:** Color  Kitty's  **red**.

Color  the pictures to match the .

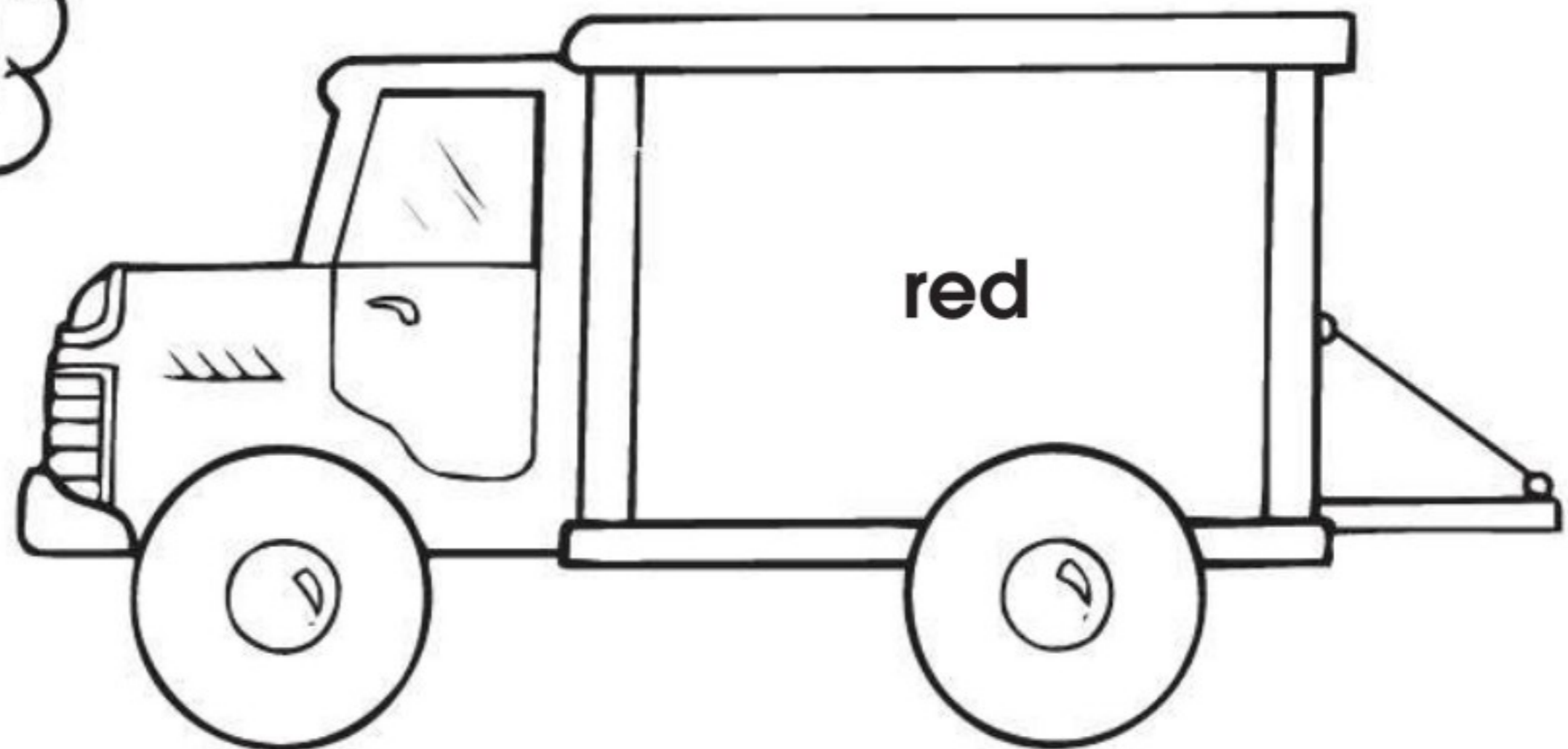
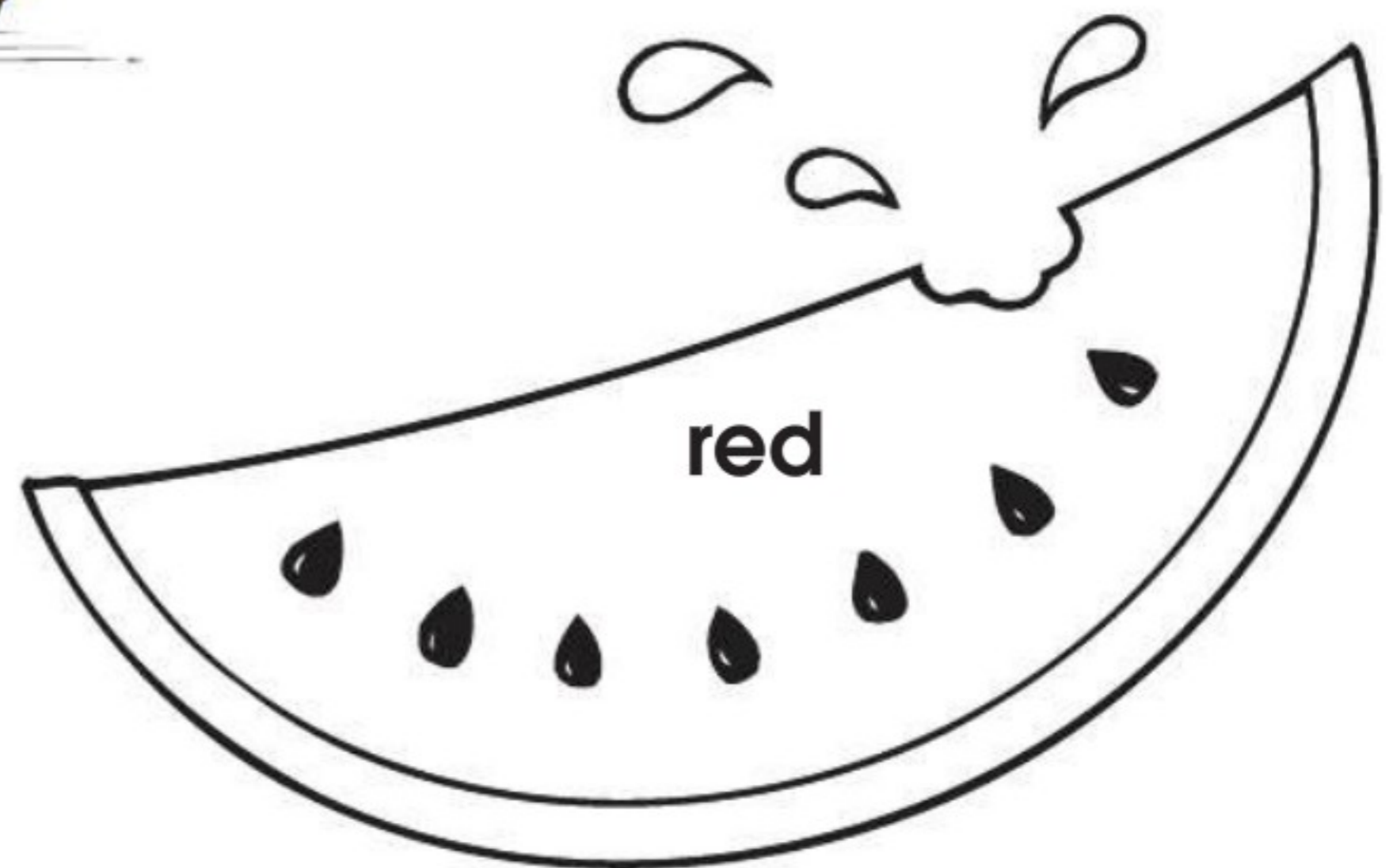
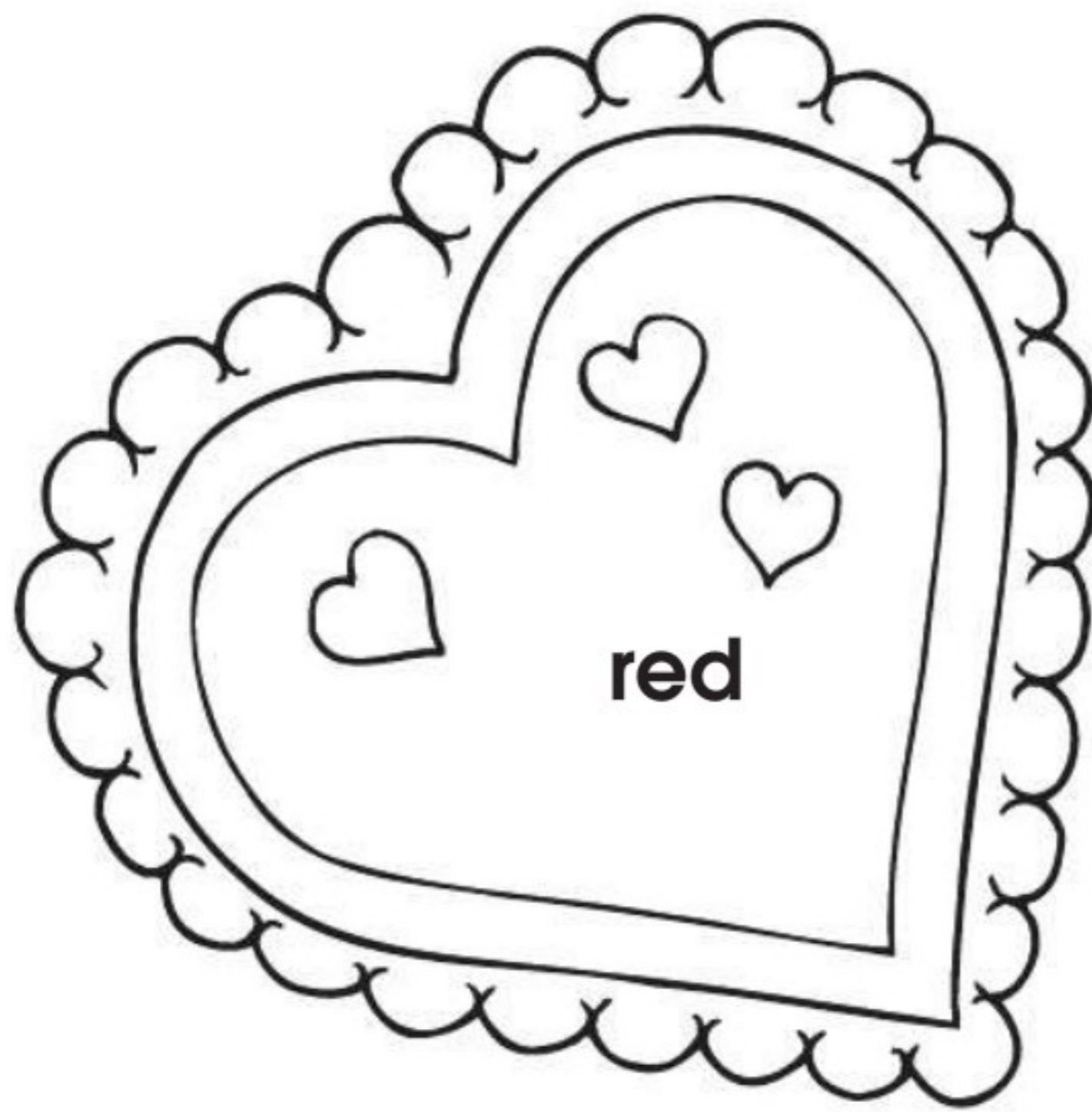
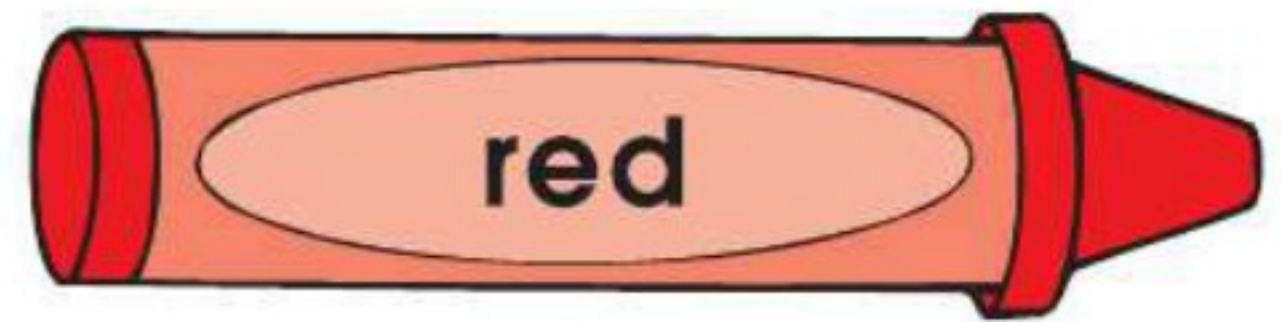
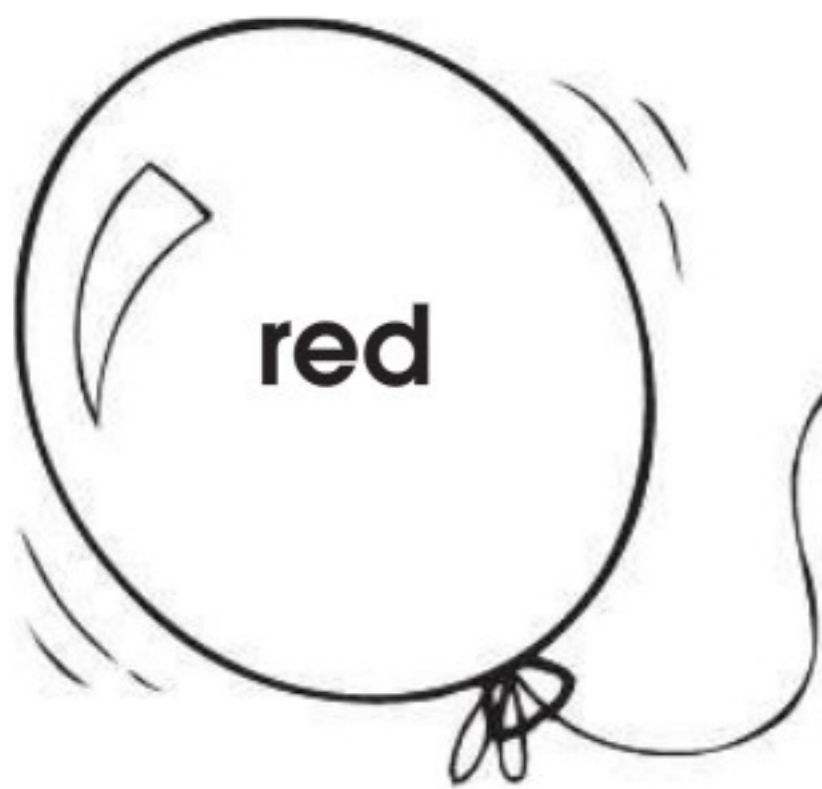

**Note to Parents:** Have a scavenger hunt in your home to gather red items with your child.

Name \_\_\_\_\_

COLORS



## Trace and Write Red

**Directions:** Trace  the word "red" in the second box below. Then, in the third box, write  "red" on your own.

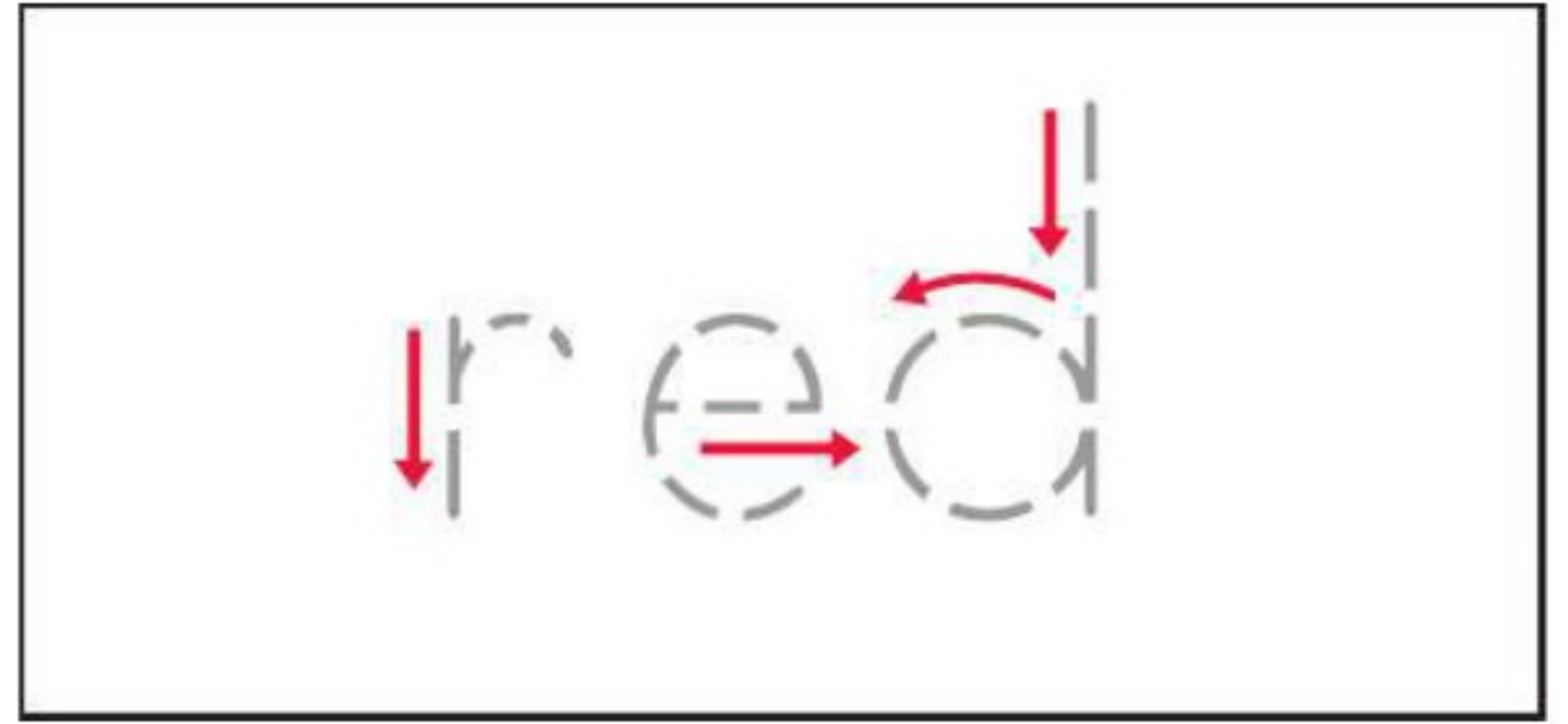

**Directions:** Which three could be red?

Color  with red.

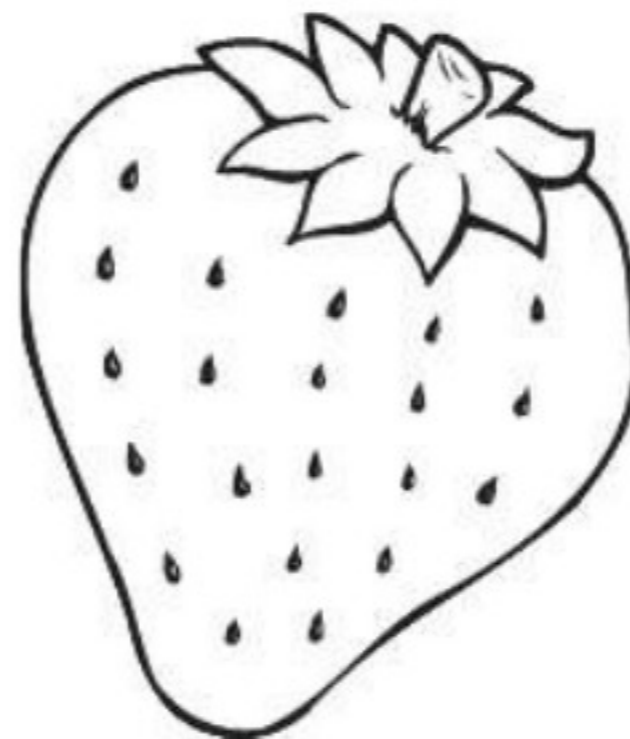
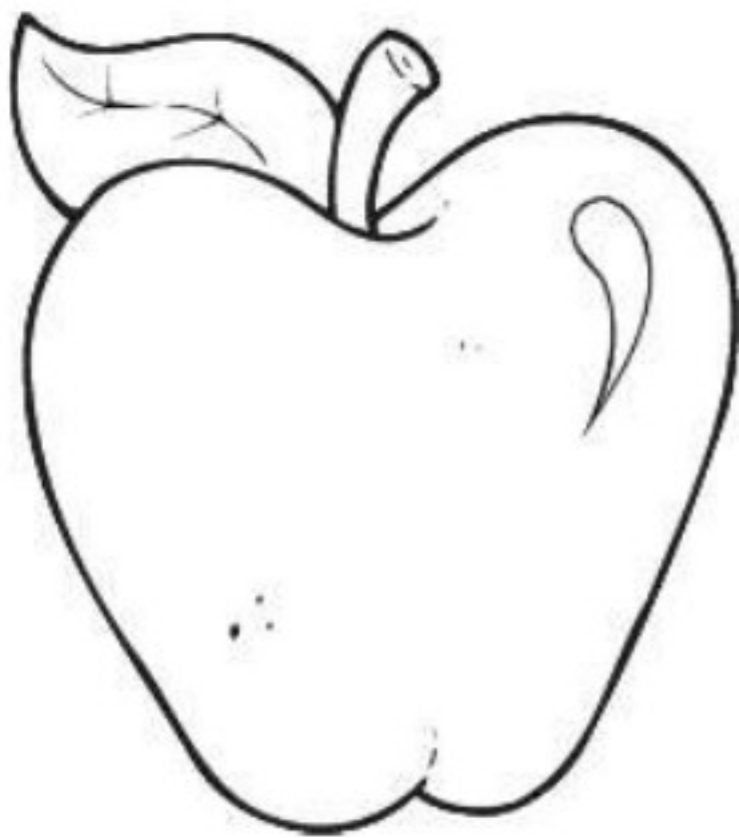
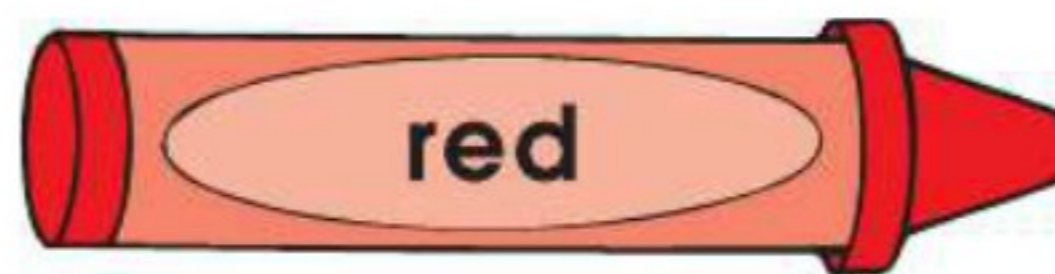

**Note to Parents:** Ask your child to name things that are red.



# Color Yellow Things

**Directions:** Color  Dilly's  **yellow**.

Color  the pictures to match the .

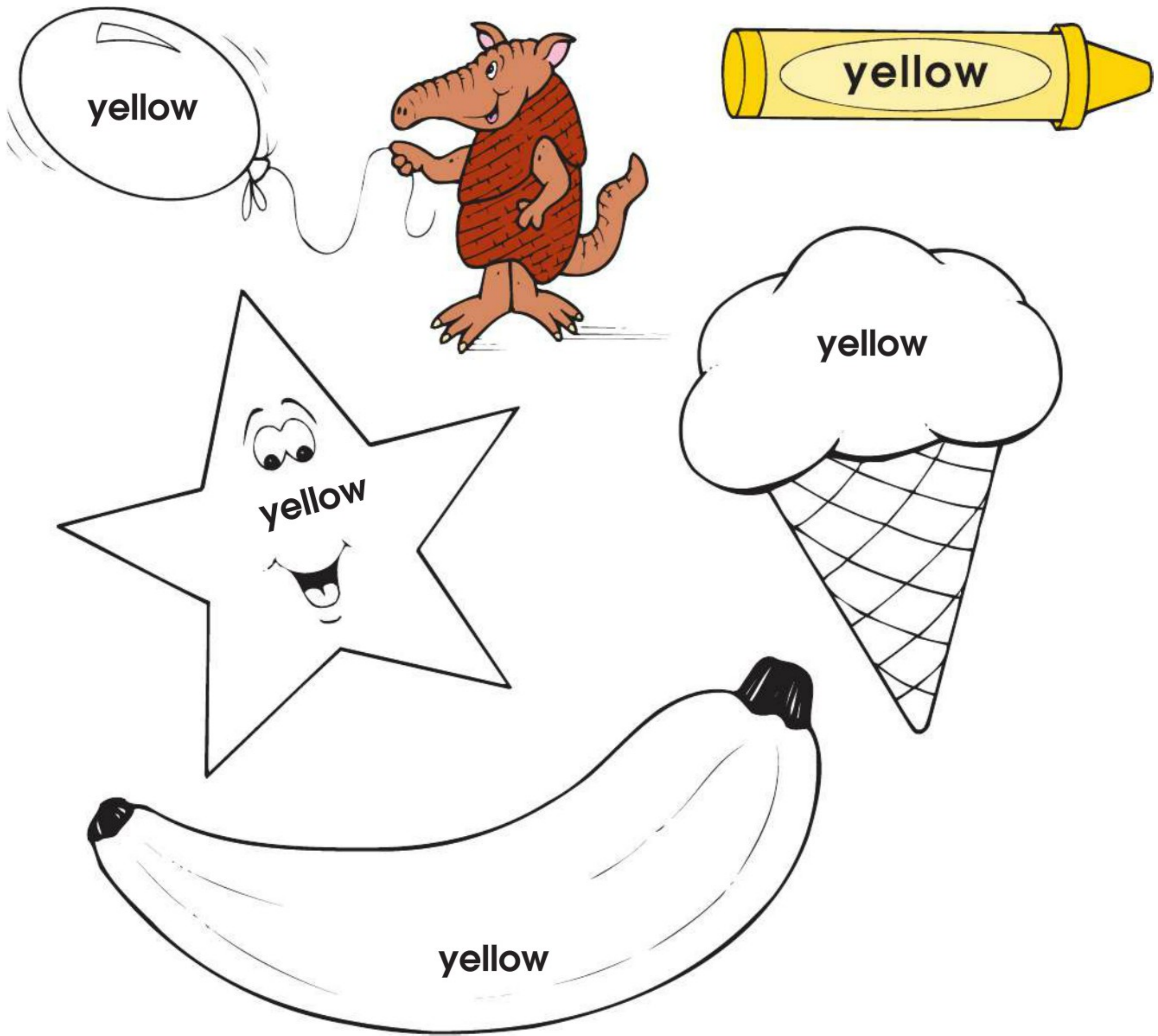

**Note to Parents:** Have a scavenger hunt in your home to gather yellow items with your child.





## Trace and Write Yellow

**Directions:** Trace  the word "yellow" in the second box below. Then, in the third box, write  "yellow" on your own.

yellow

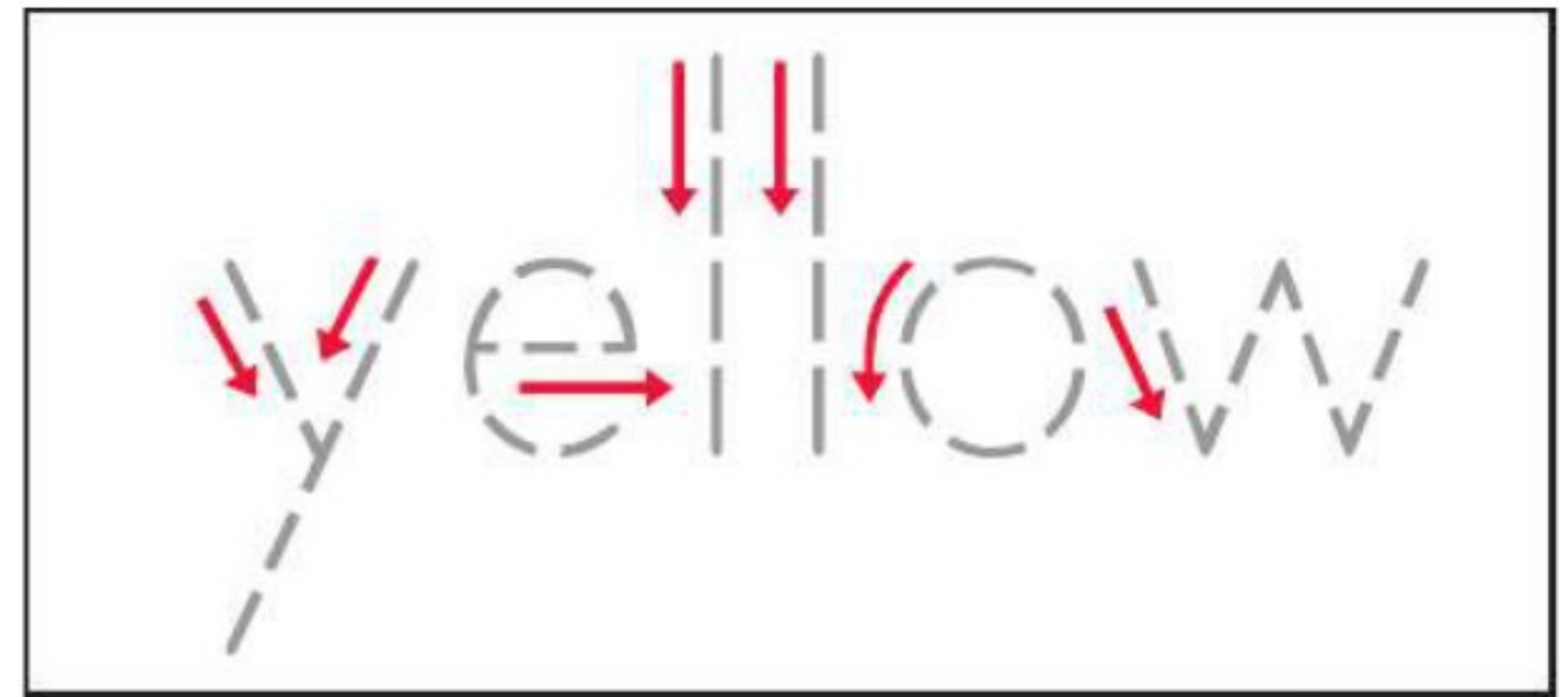

**Directions:** Which three could be yellow? Color  with yellow.

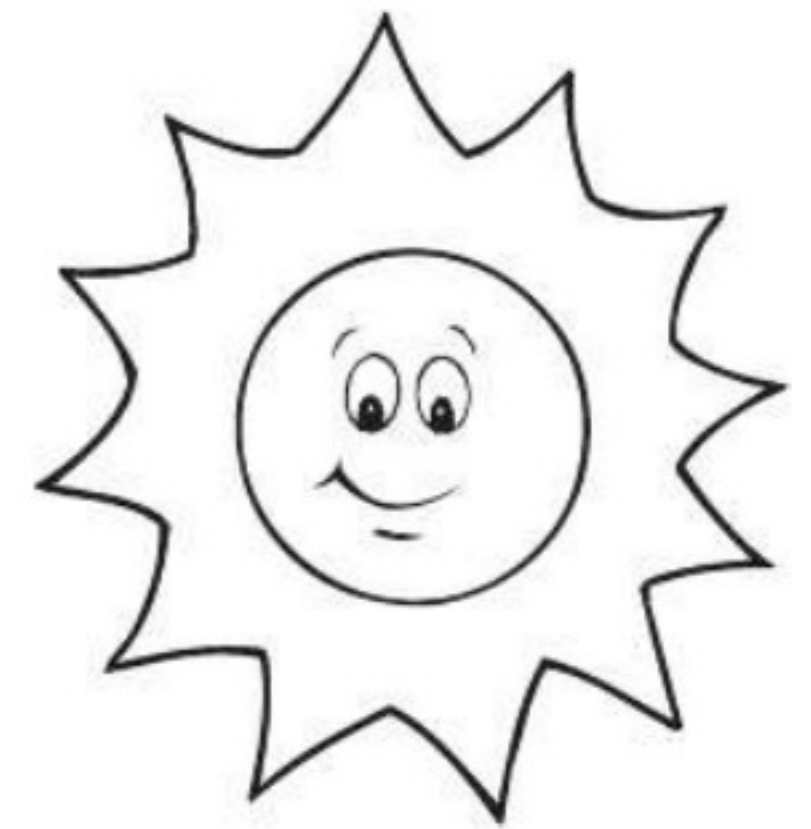
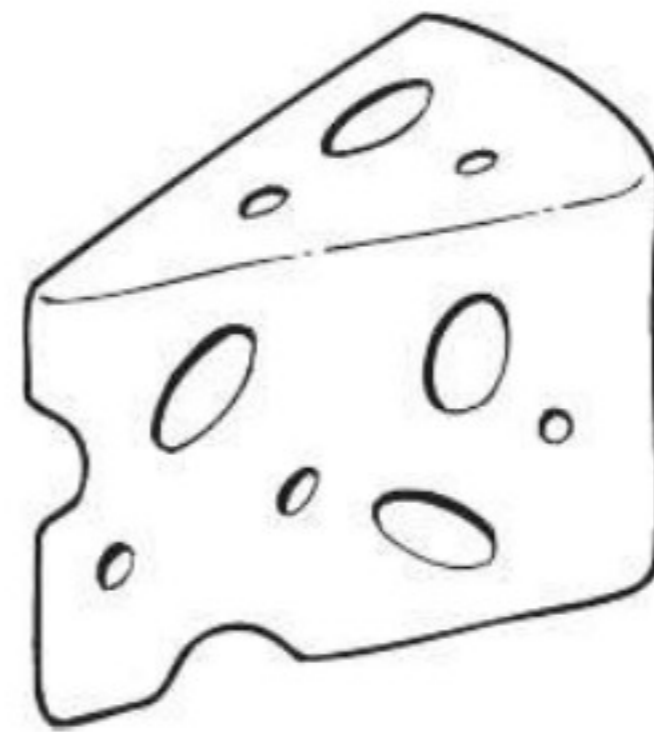
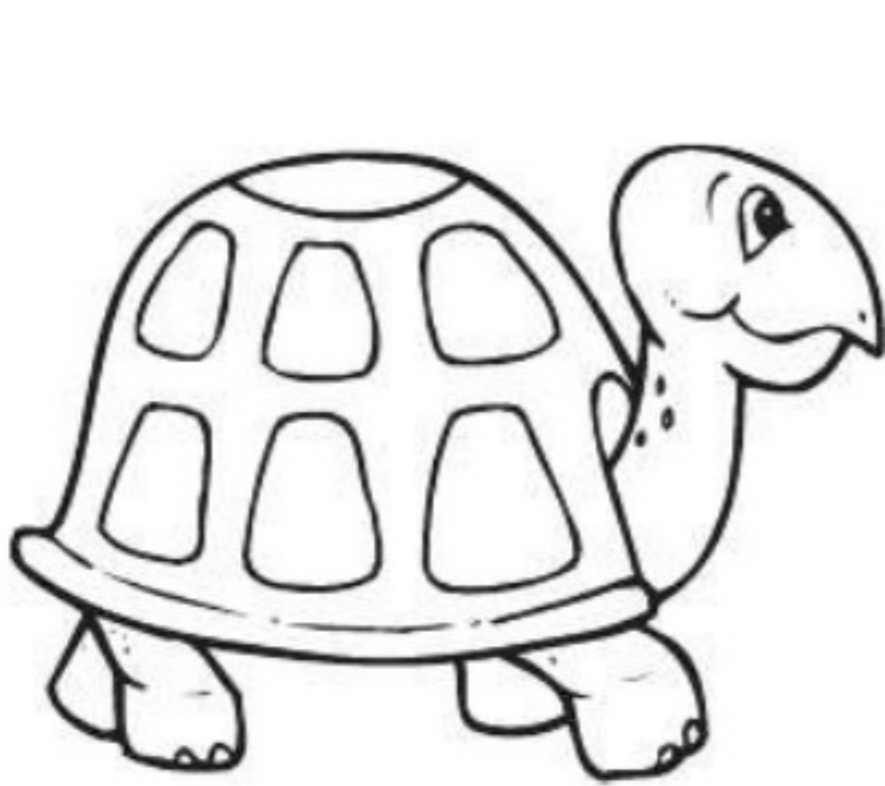

**Note to Parents:** Ask your child to name things that are yellow.



# Color Blue Things

**Directions:** Color  Teddy's  **blue**.

Color  the pictures to match the .

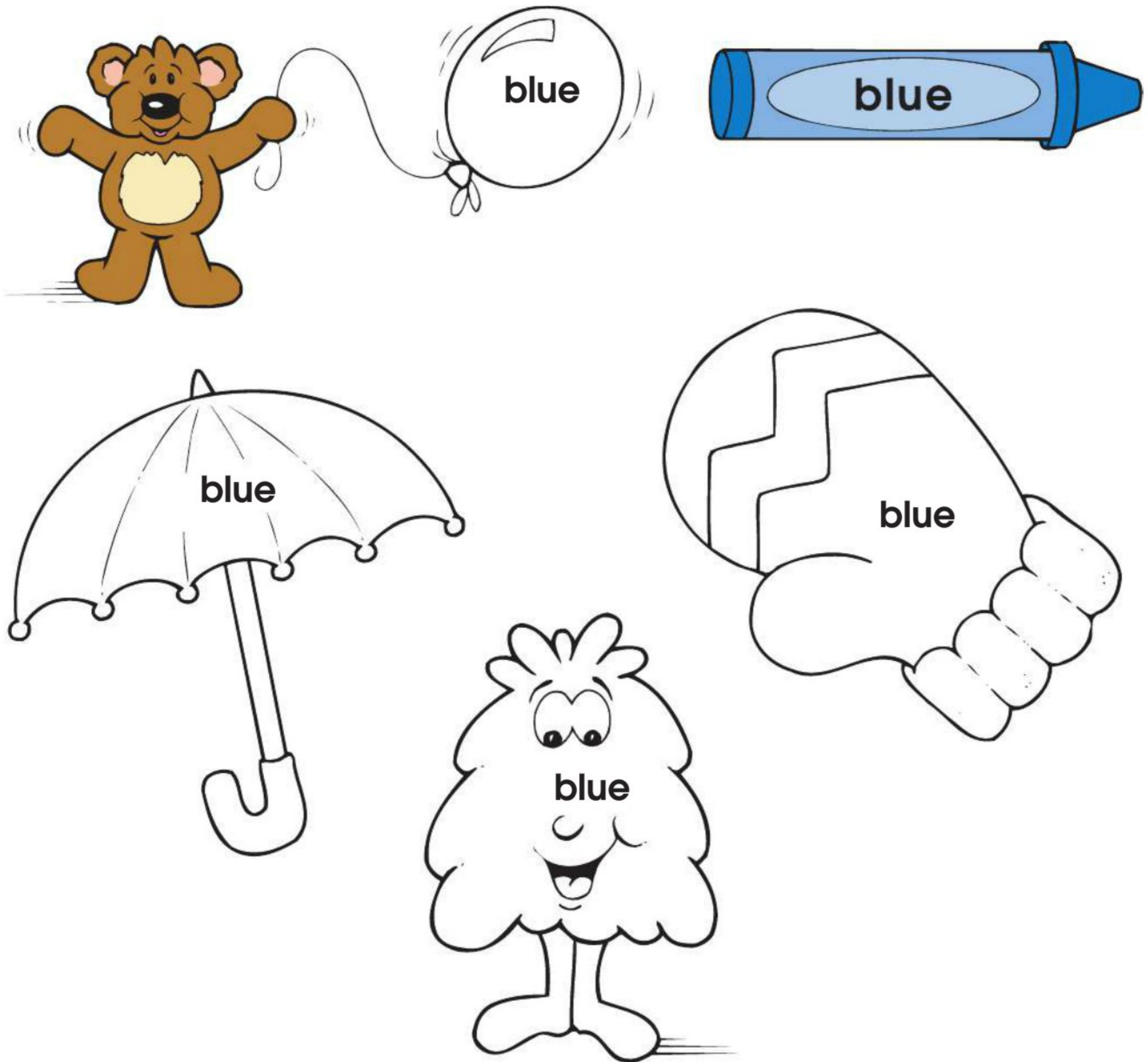

**Note to Parents:** Have a scavenger hunt in your home to gather blue items with your child.



## Trace and Write Blue

**Directions:** Trace  the word "blue" in the second box below. Then, in the third box, write  "blue" on your own.

blue

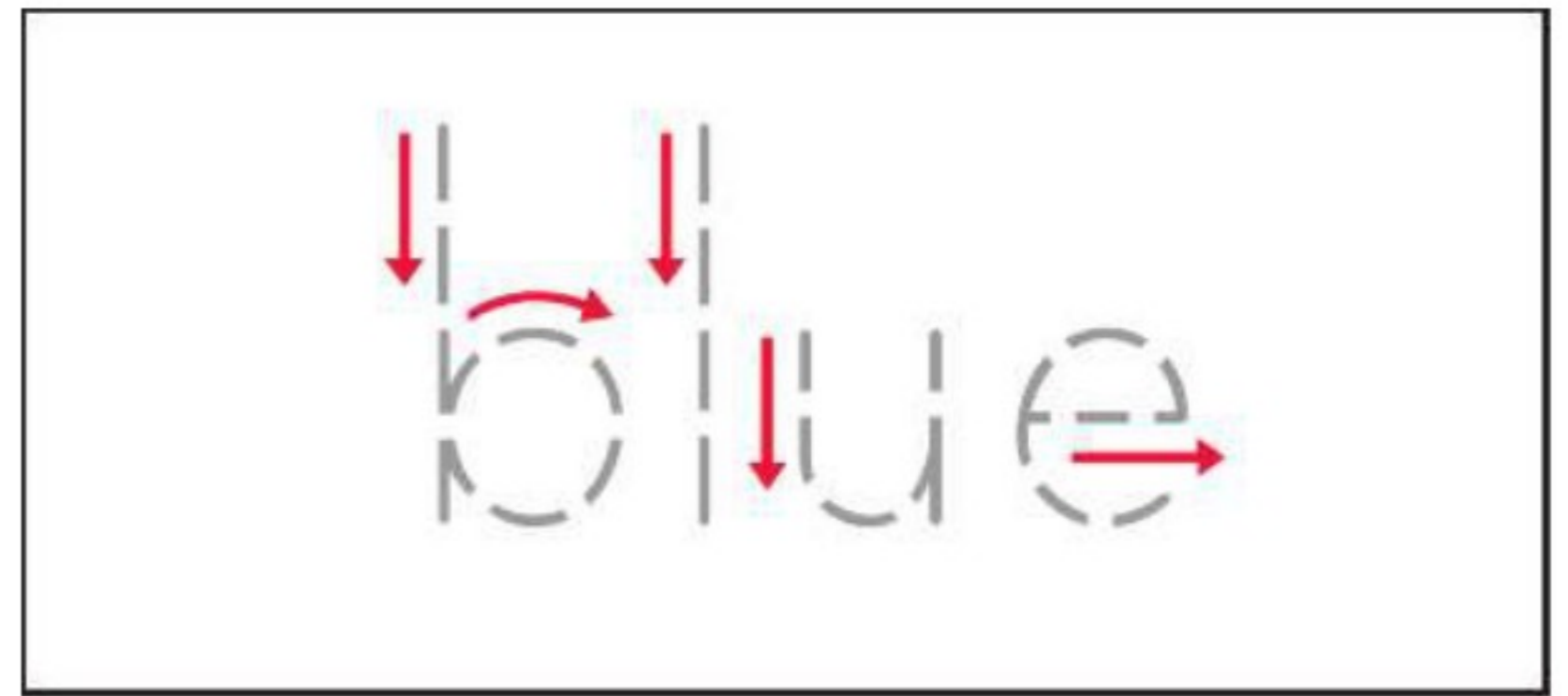

**Directions:** Which three could be blue? Color  with blue.

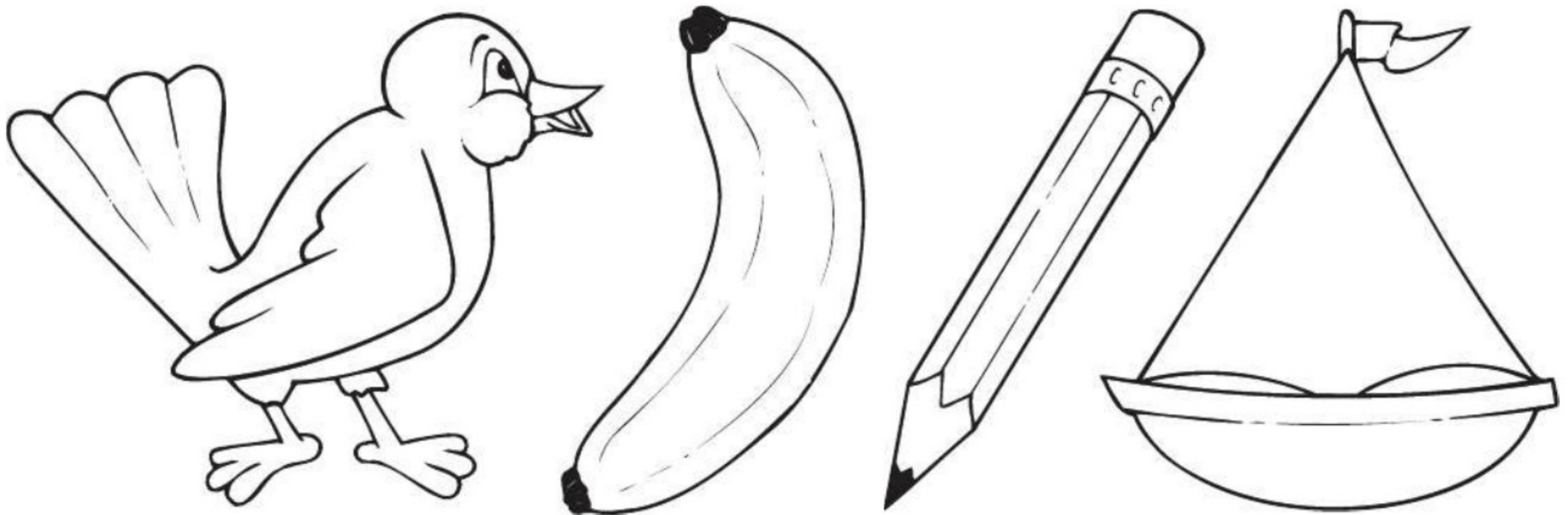

**Note to Parents:** Ask your child to name things that are blue.



# Color Brown Things

**Directions:** Color  Kangaroo's  **brown**.

Color  the pictures to match the .

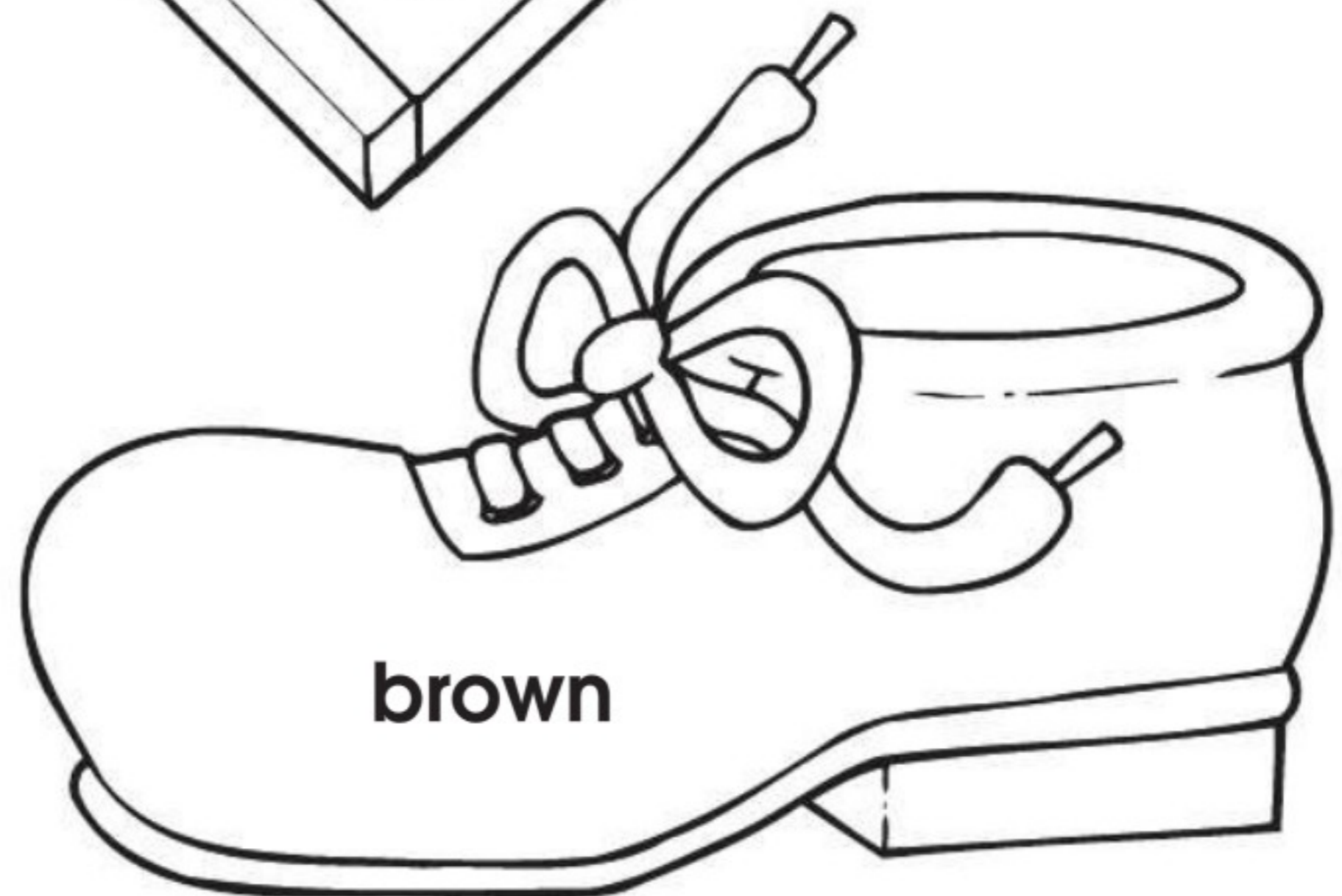
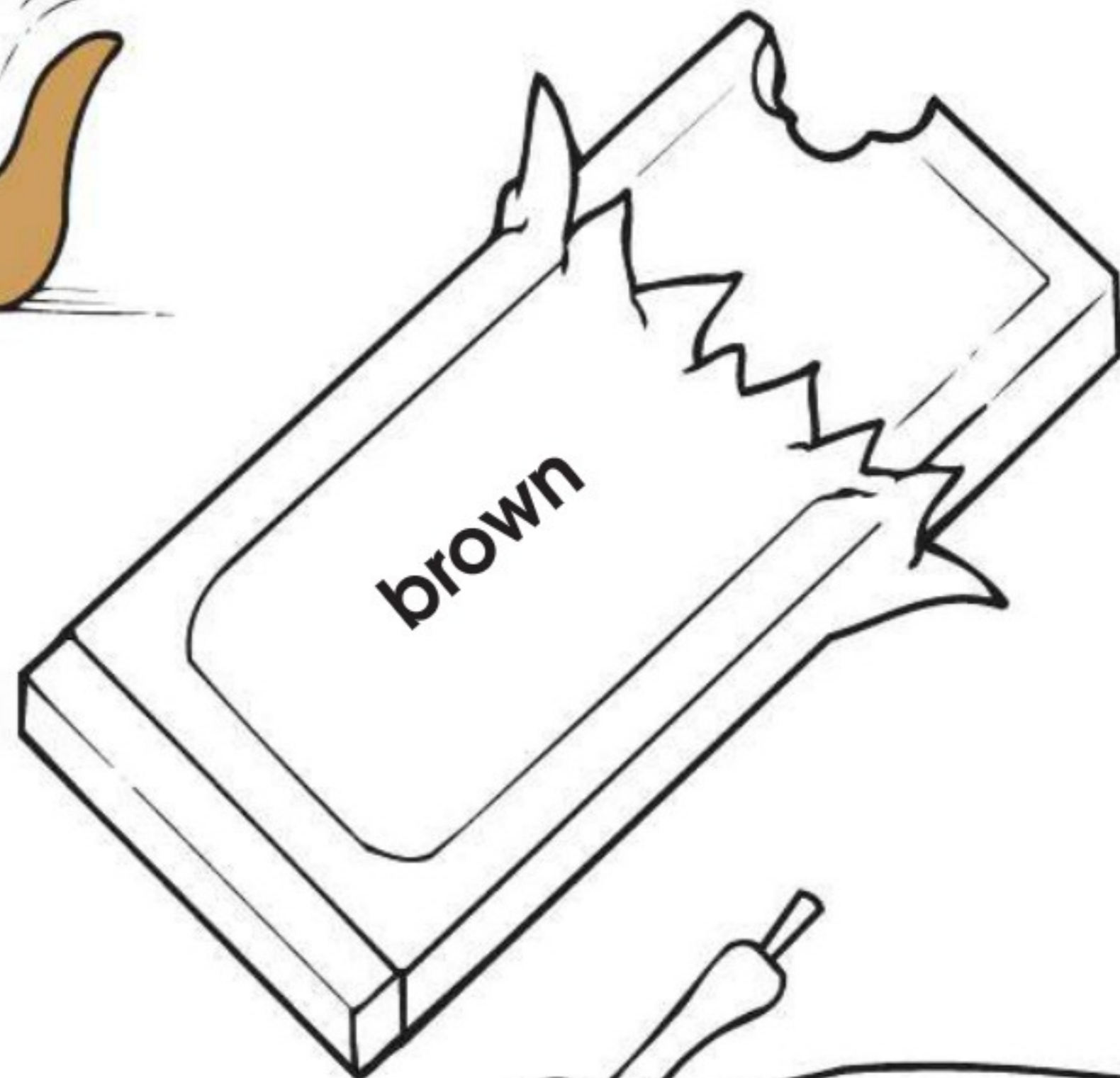
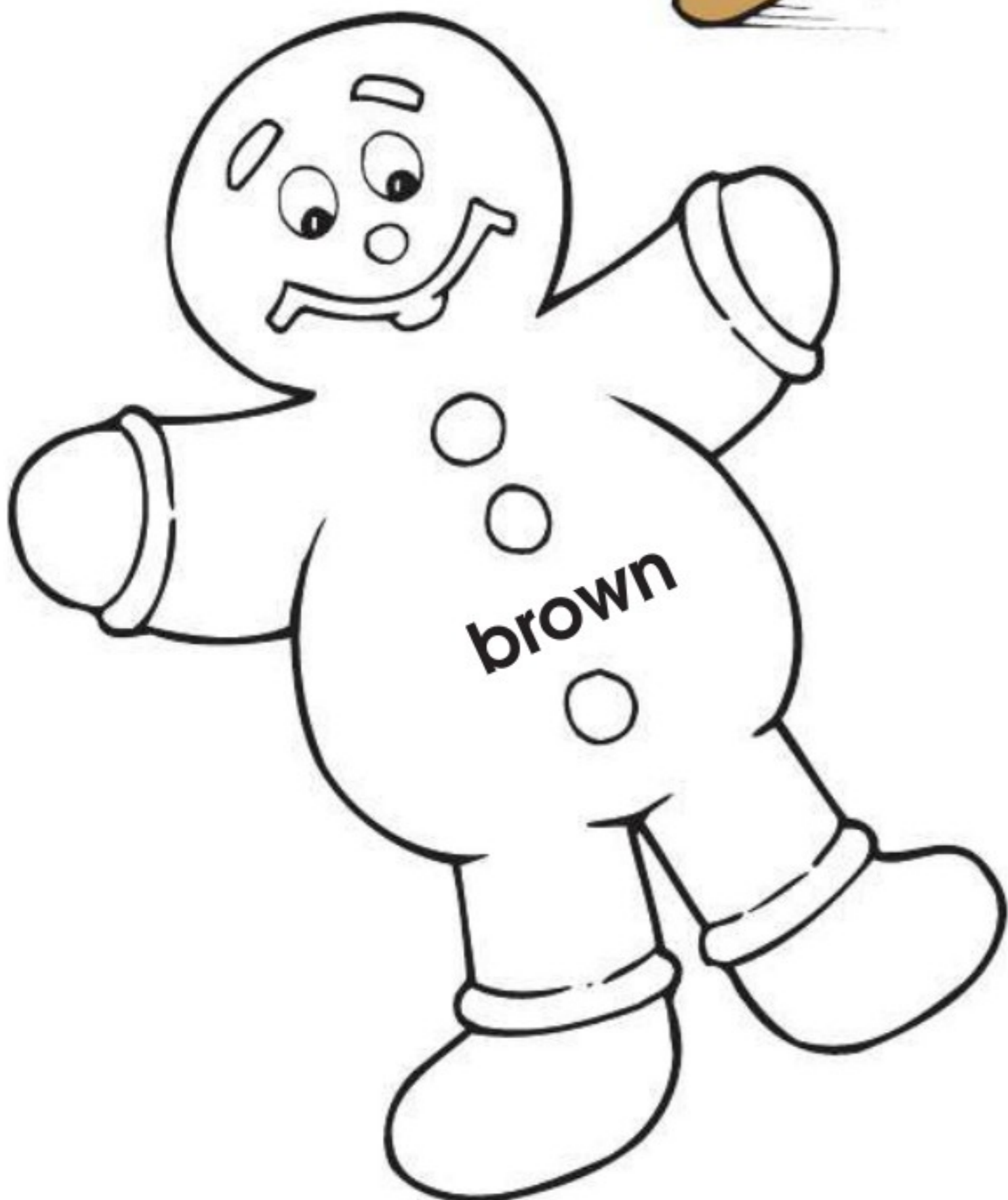
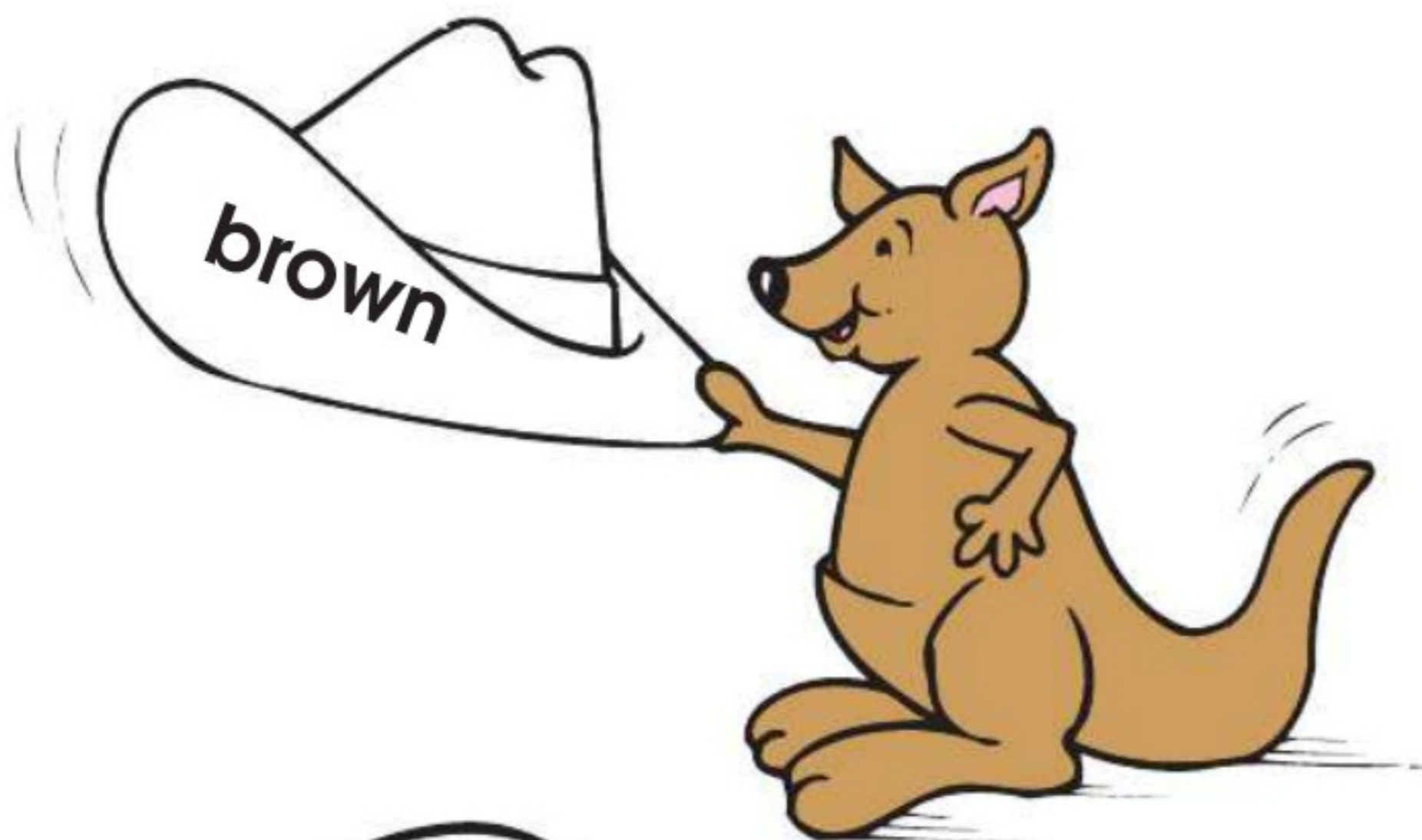

**Note to Parents:** Have a scavenger hunt in your home to gather brown items with your child.



## Trace and Write Brown

**Directions:** Trace  the word "brown" in the second box below. Then, in the third box, write  "brown" on your own.

brown

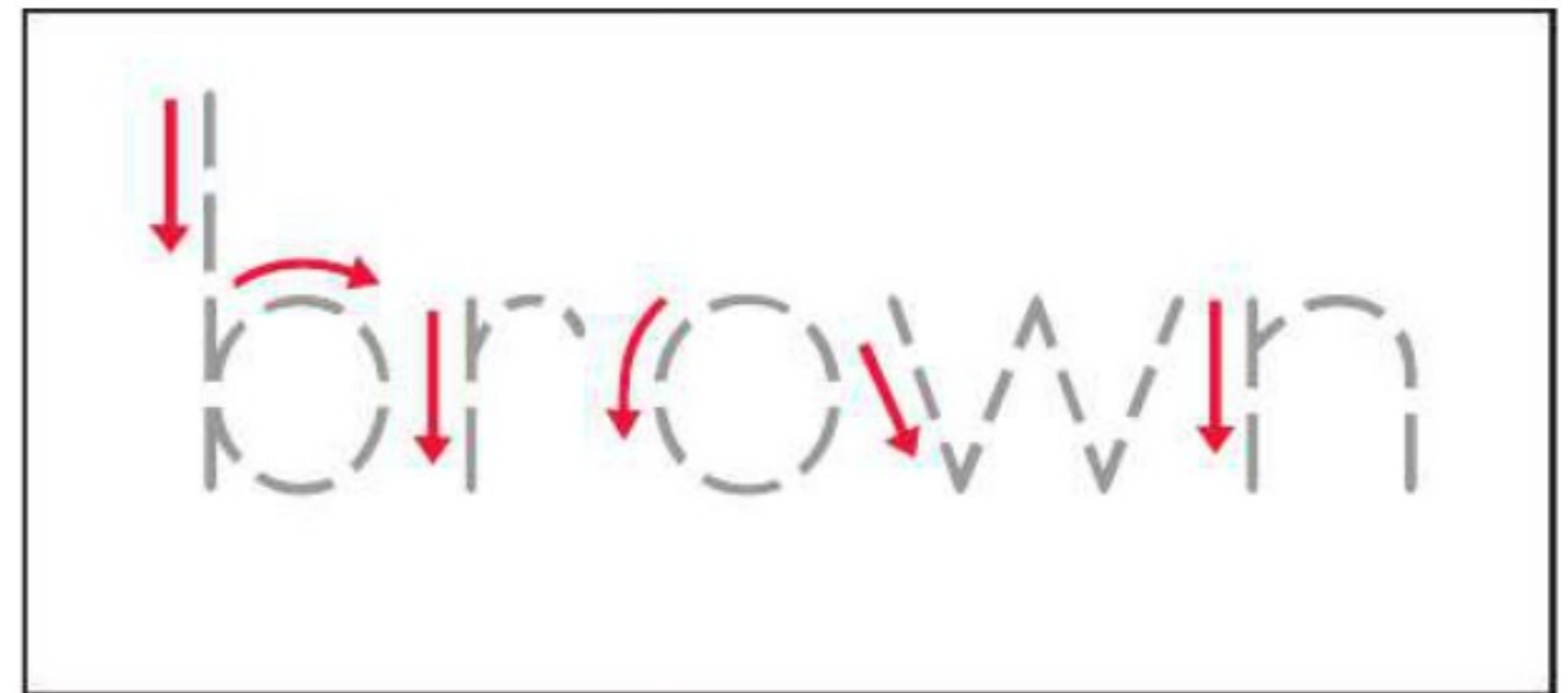

**Directions:** Which three could be brown? Color  with brown.

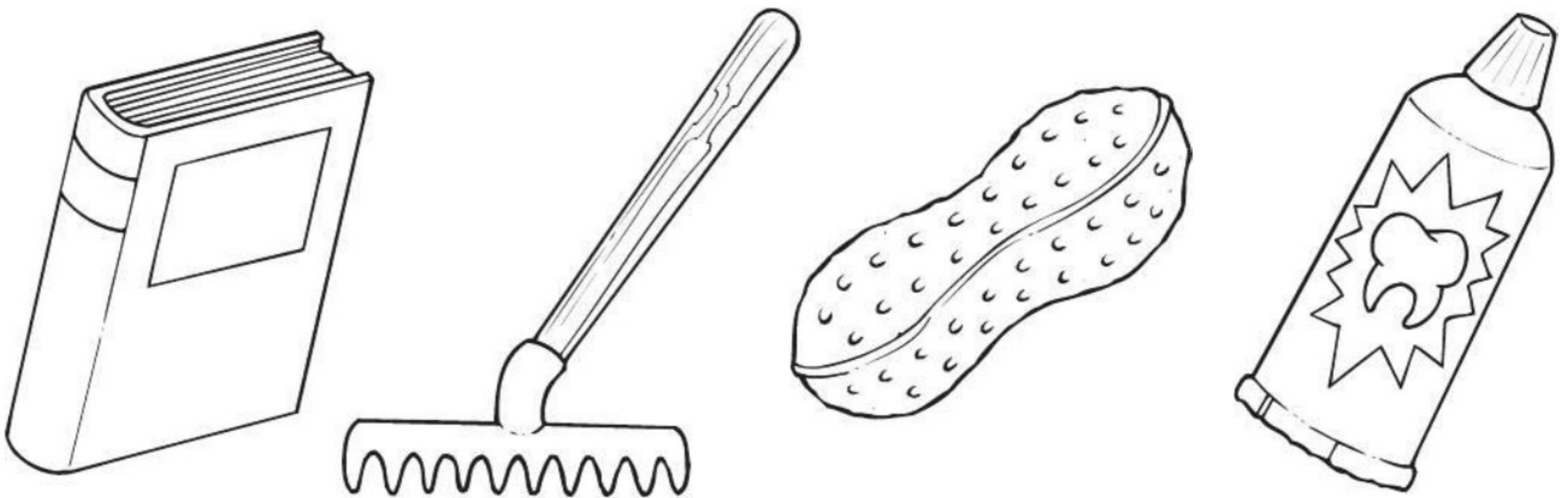

**Note to Parents:** Ask your child to name things that are brown.



# Color Green Things

**Directions:** Color  Racky's  **green.**

Color  the pictures to match the .

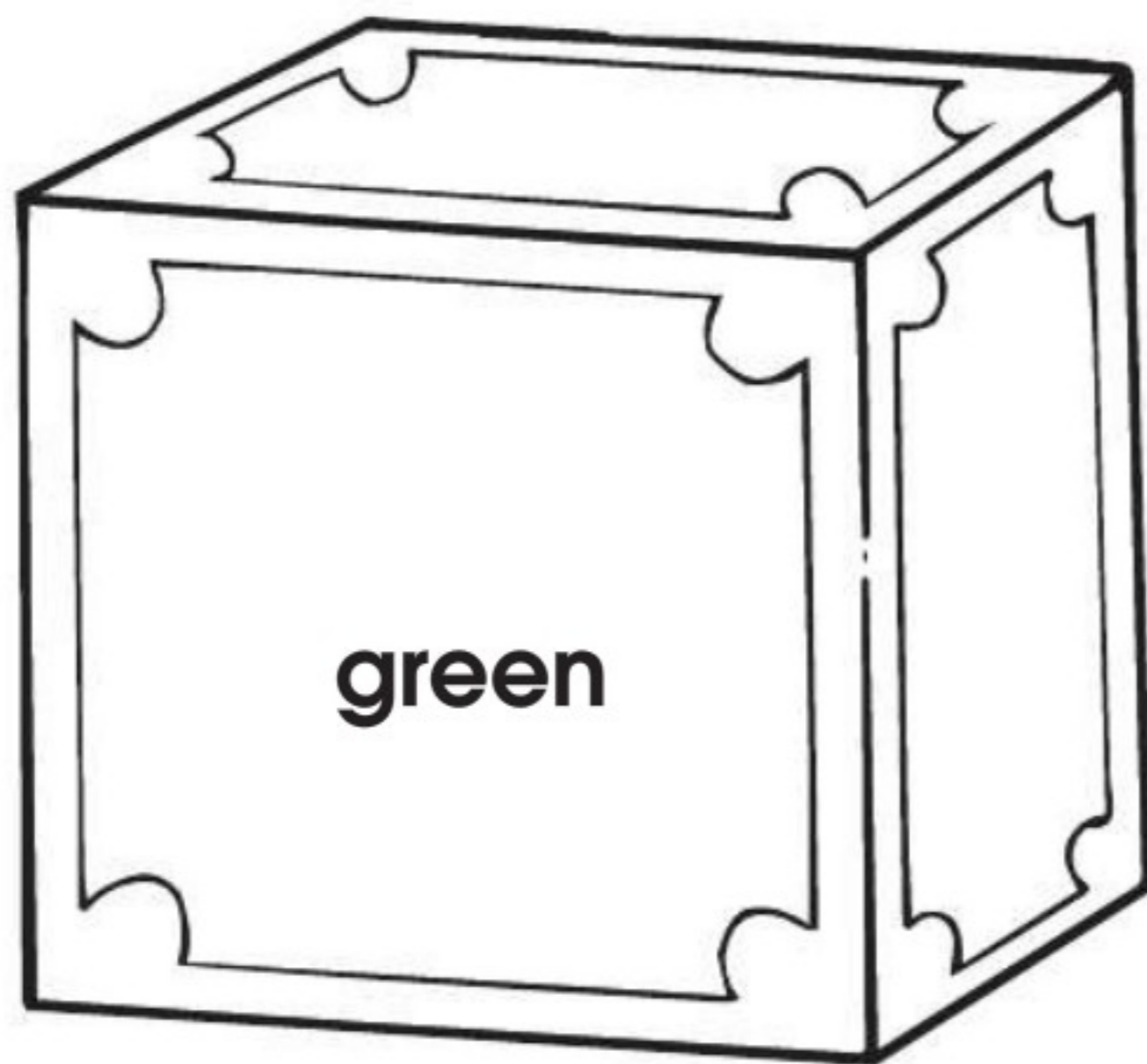
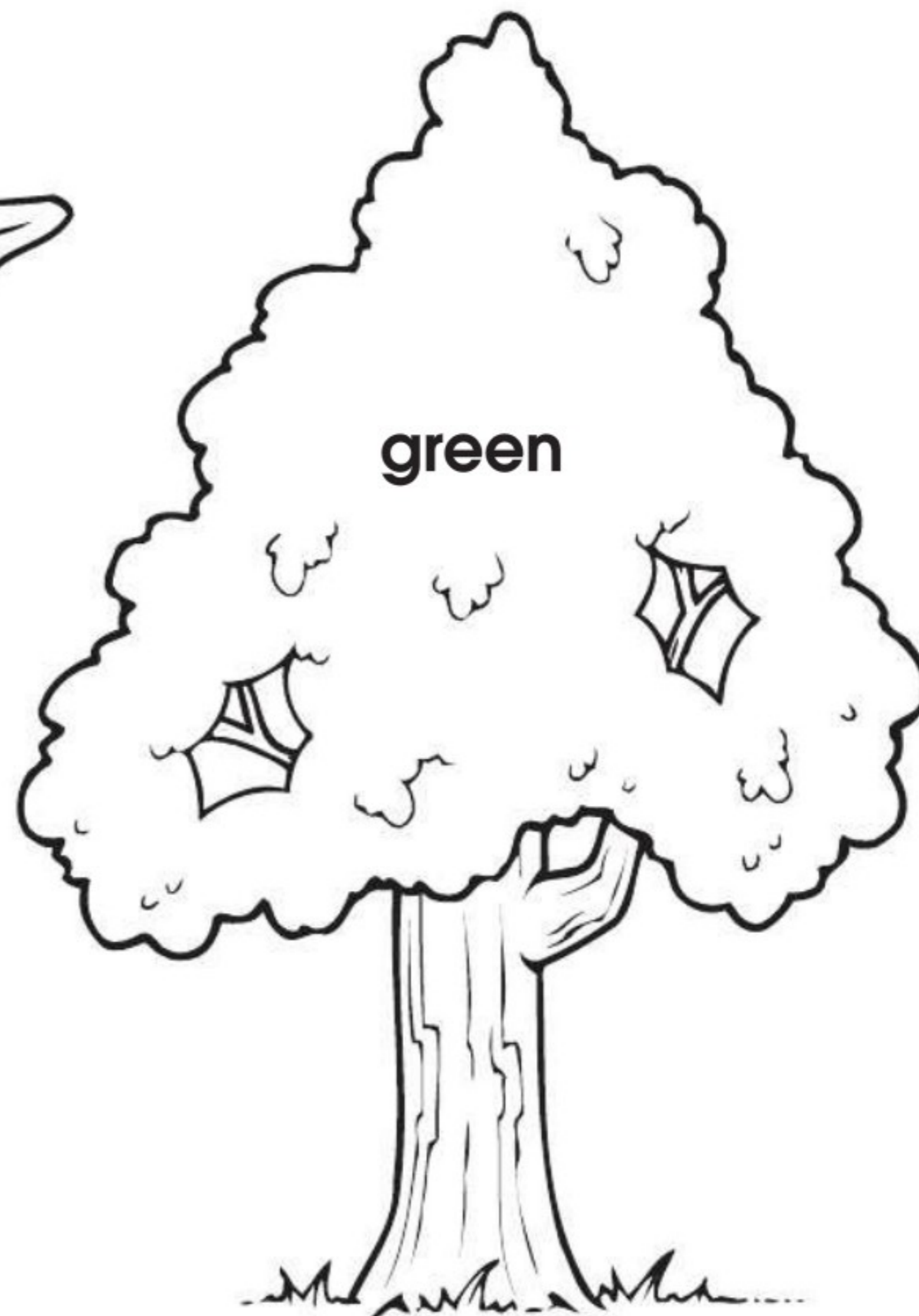
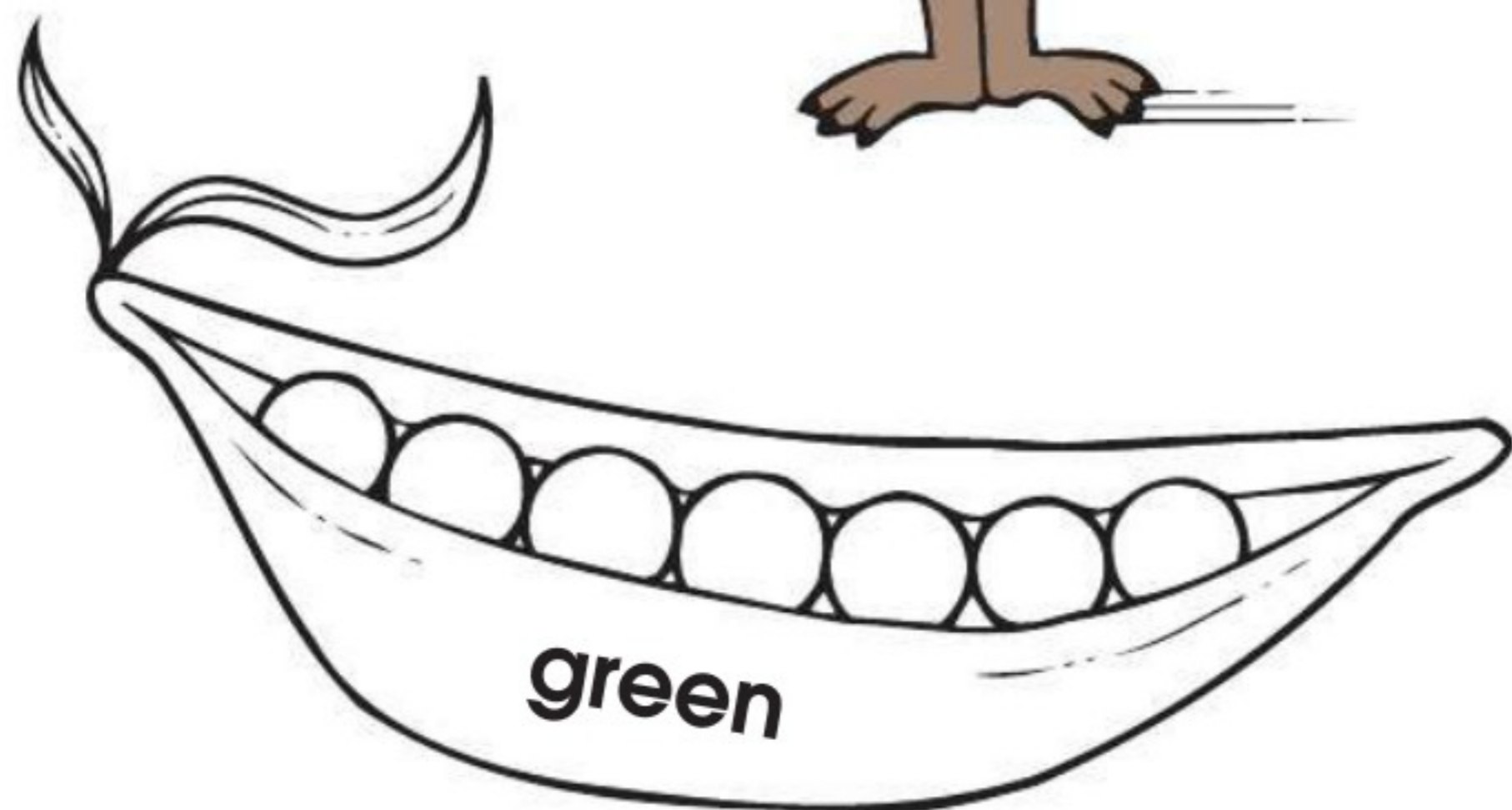
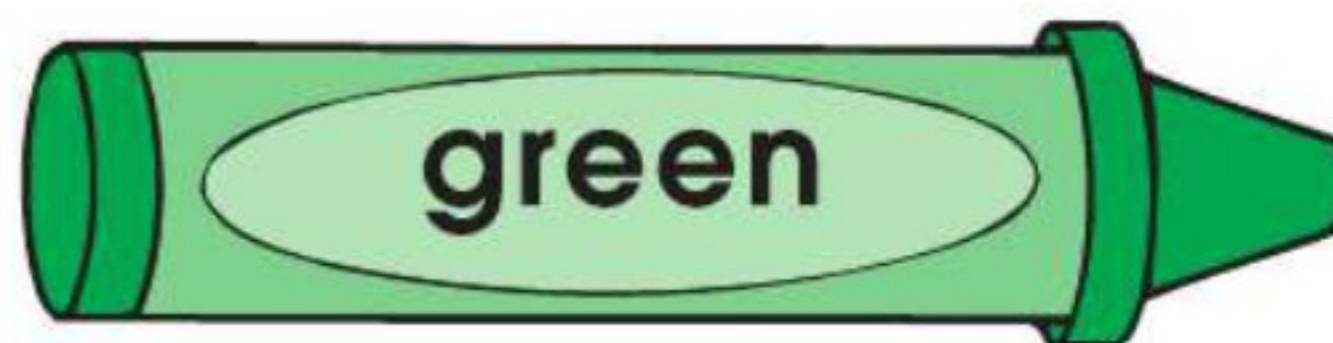
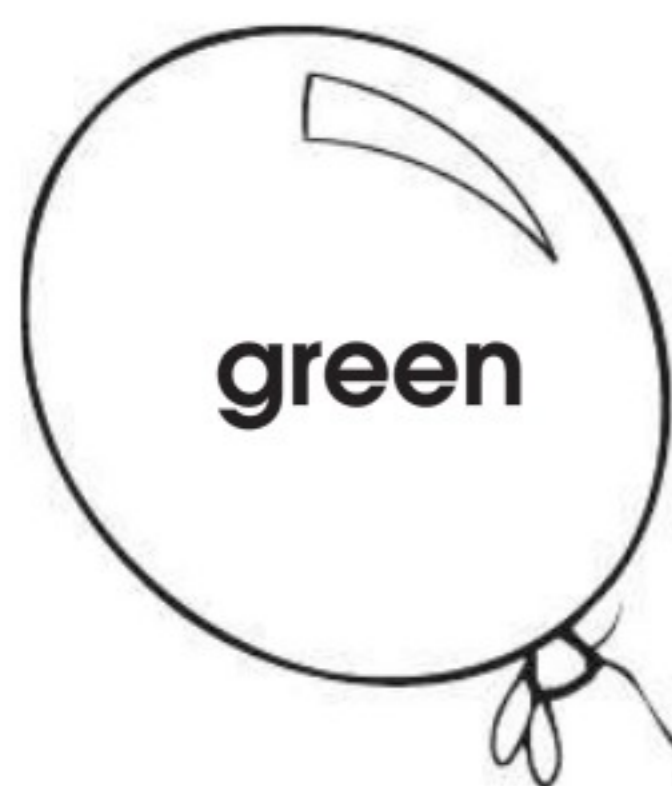

**Note to Parents:** Have a scavenger hunt in your home to gather green items with your child.



## Trace and Write Green

**Directions:** Trace  the word "green" in the second box below. Then, in the third box, write  "green" on your own.

green

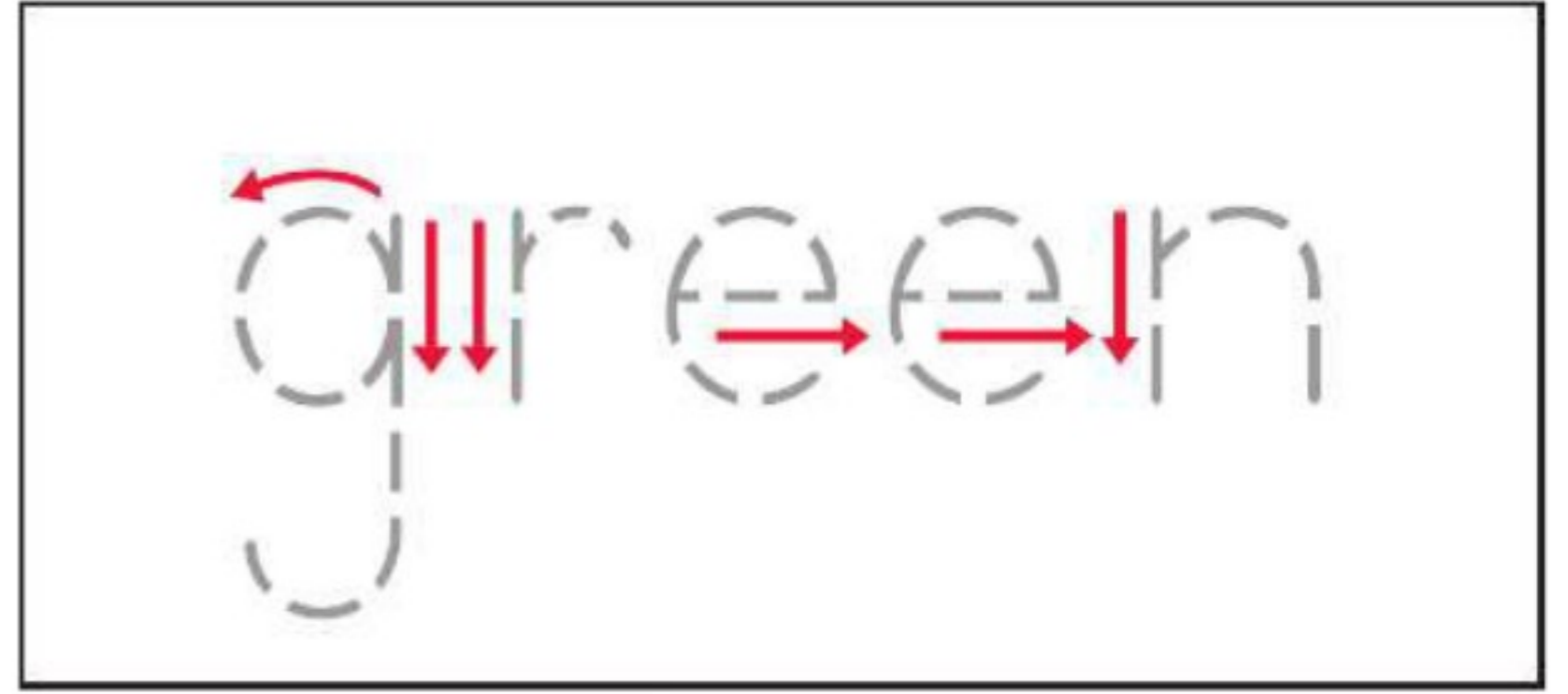

**Directions:** Which three could be green? Color  with green.

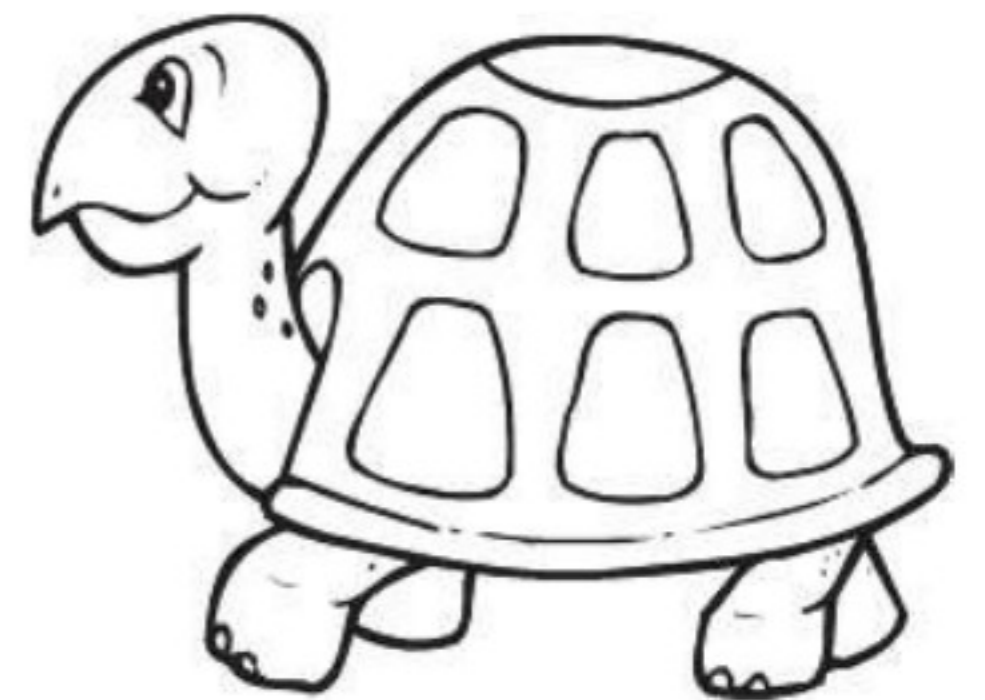
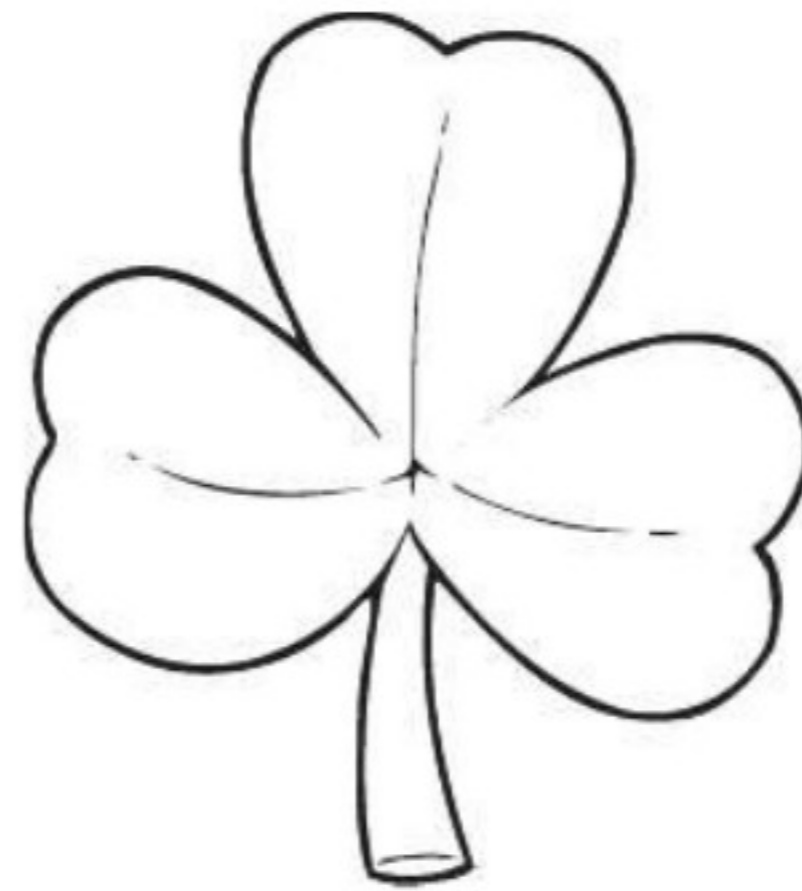
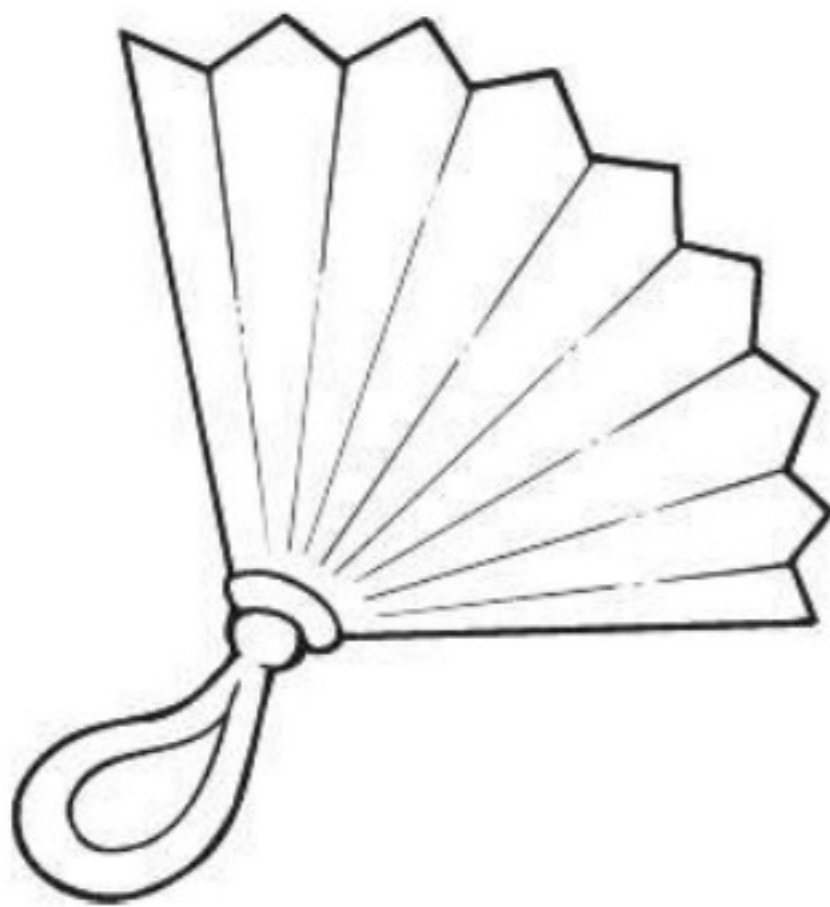

**Note to Parents:** Ask your child to name things that are green.



# Color Purple Things

**Directions:** Color  Pelly's  purple.

Color  the pictures to match the .

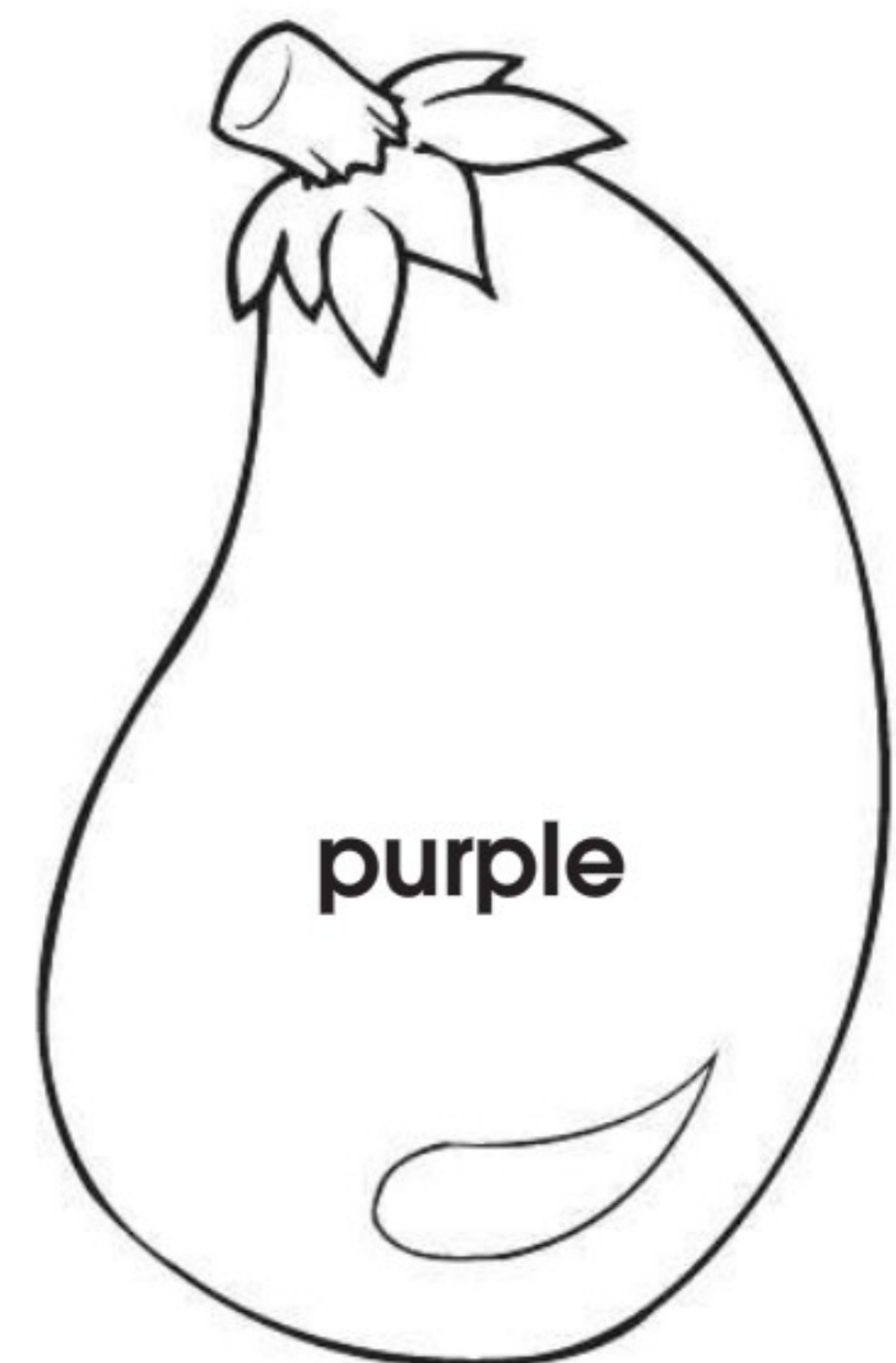
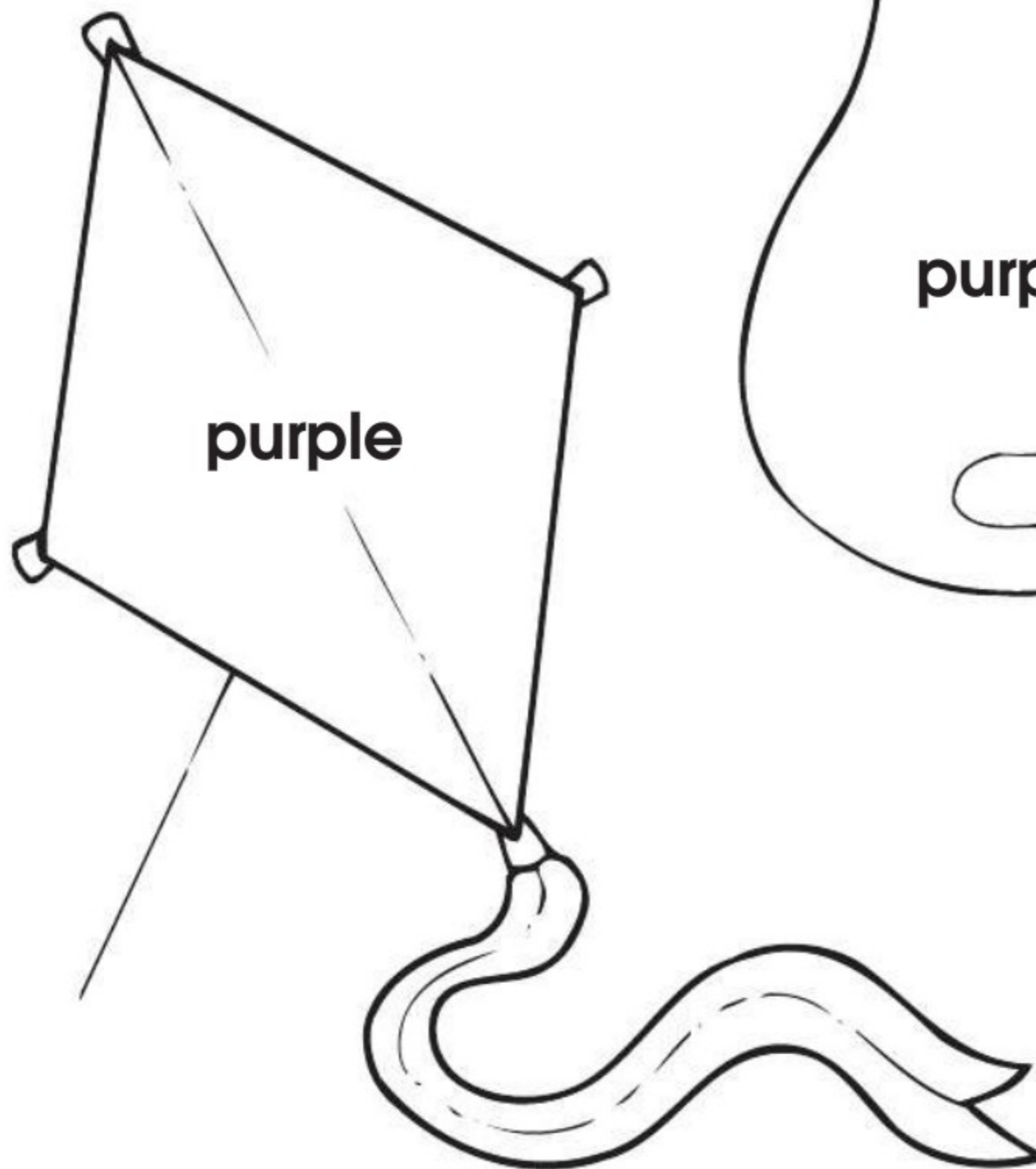
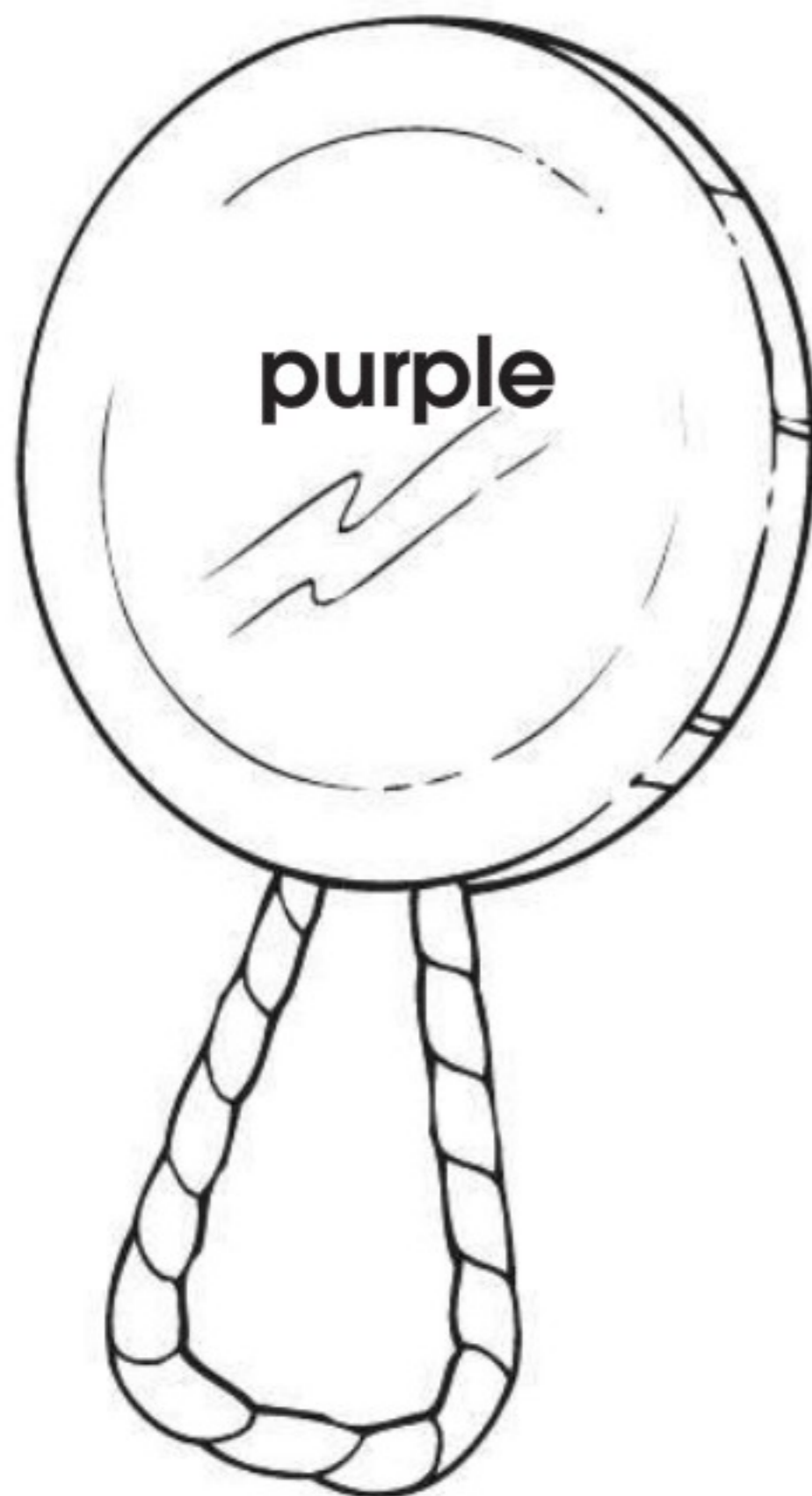
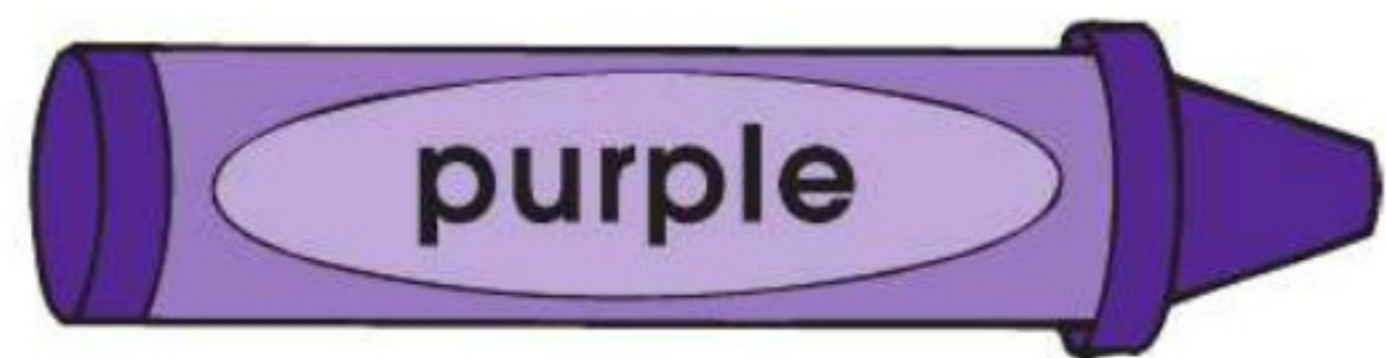
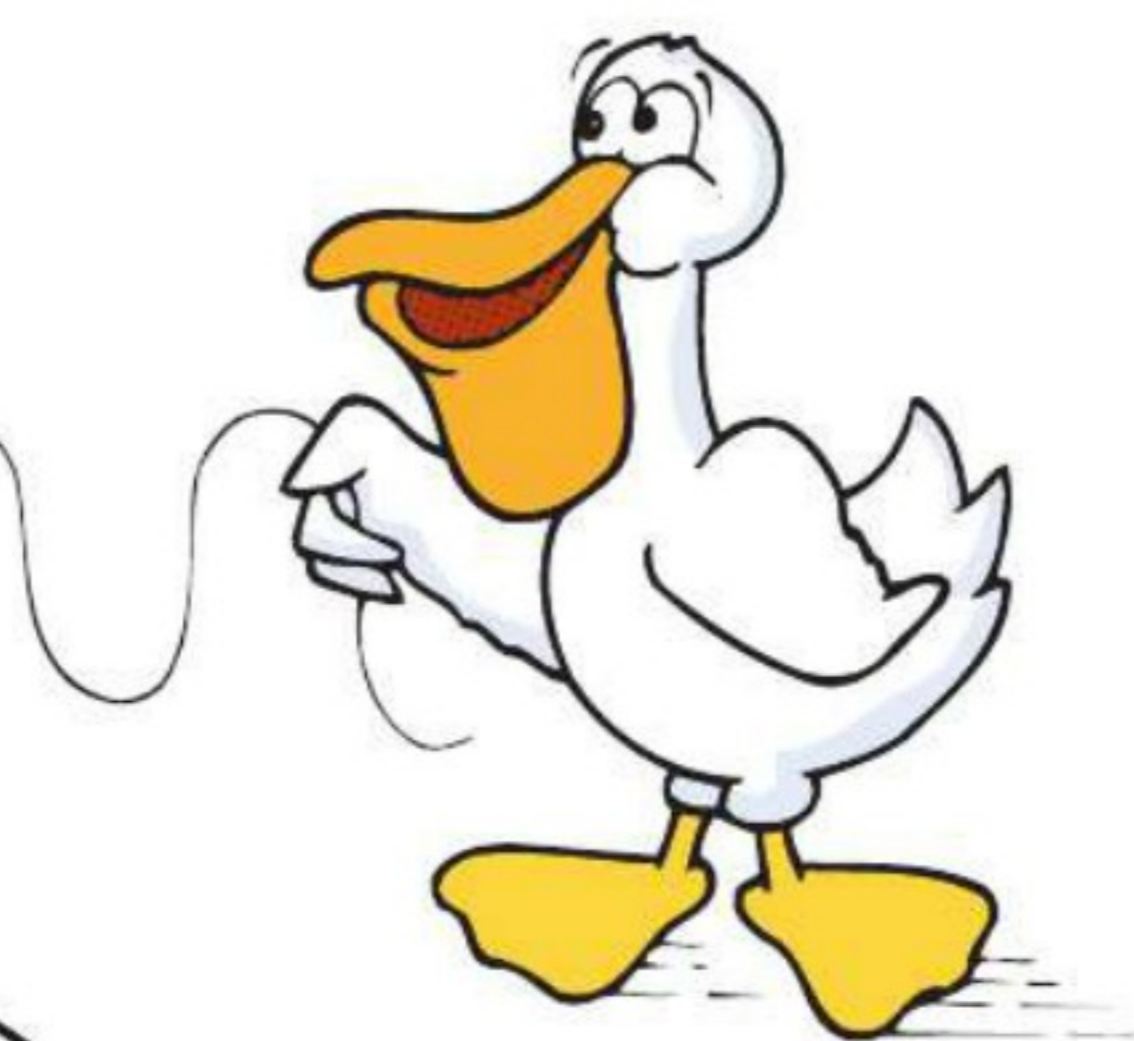
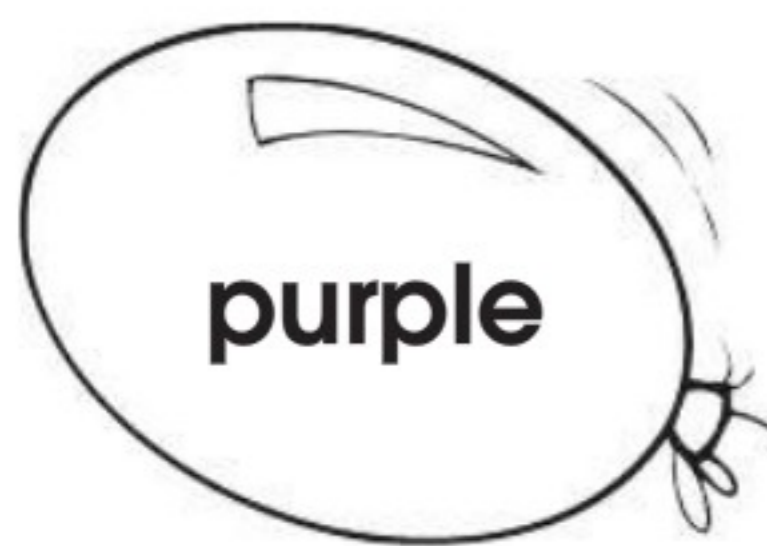

**Note to Parents:** Have a scavenger hunt in your home to gather purple items with your child.





## Trace and Write Purple

**Directions:** Trace  the word "purple" in the second box below. Then, in the third box, write  "purple" on your own.

purple

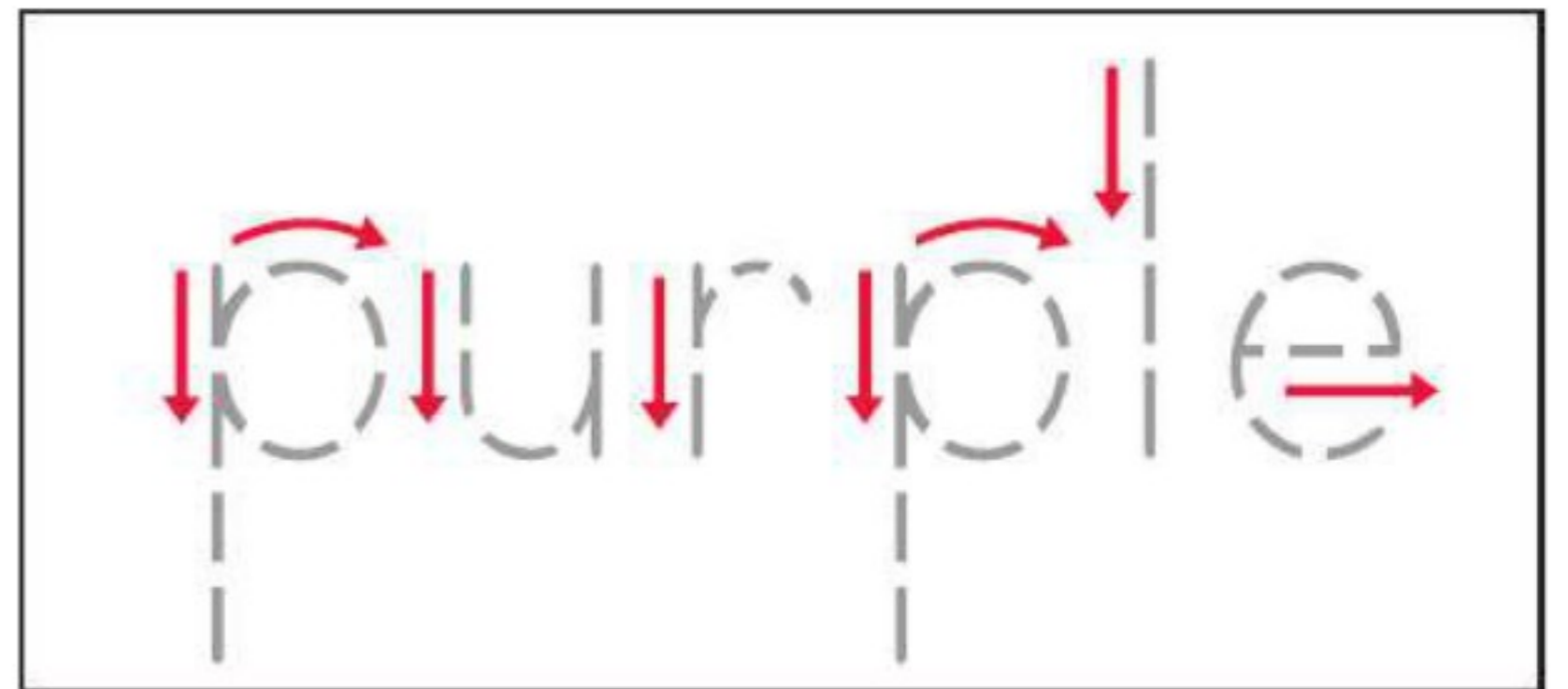

**Directions:** Which three could be purple? Color  with purple.

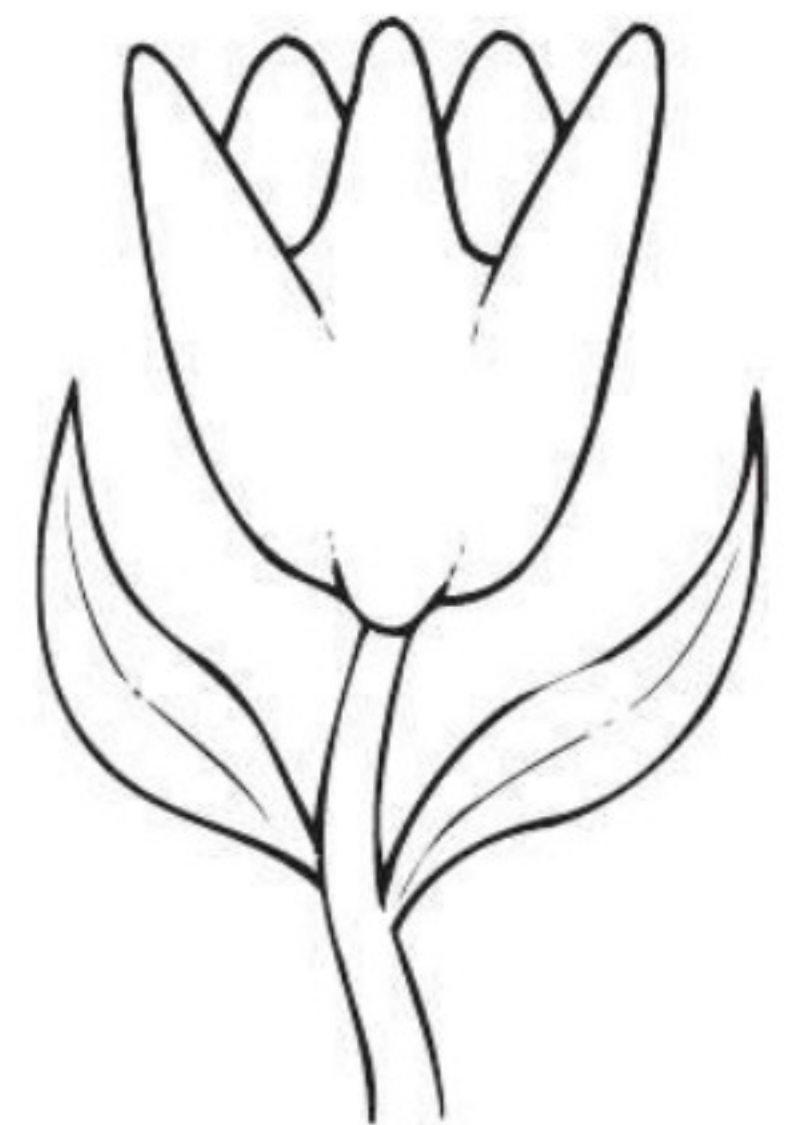
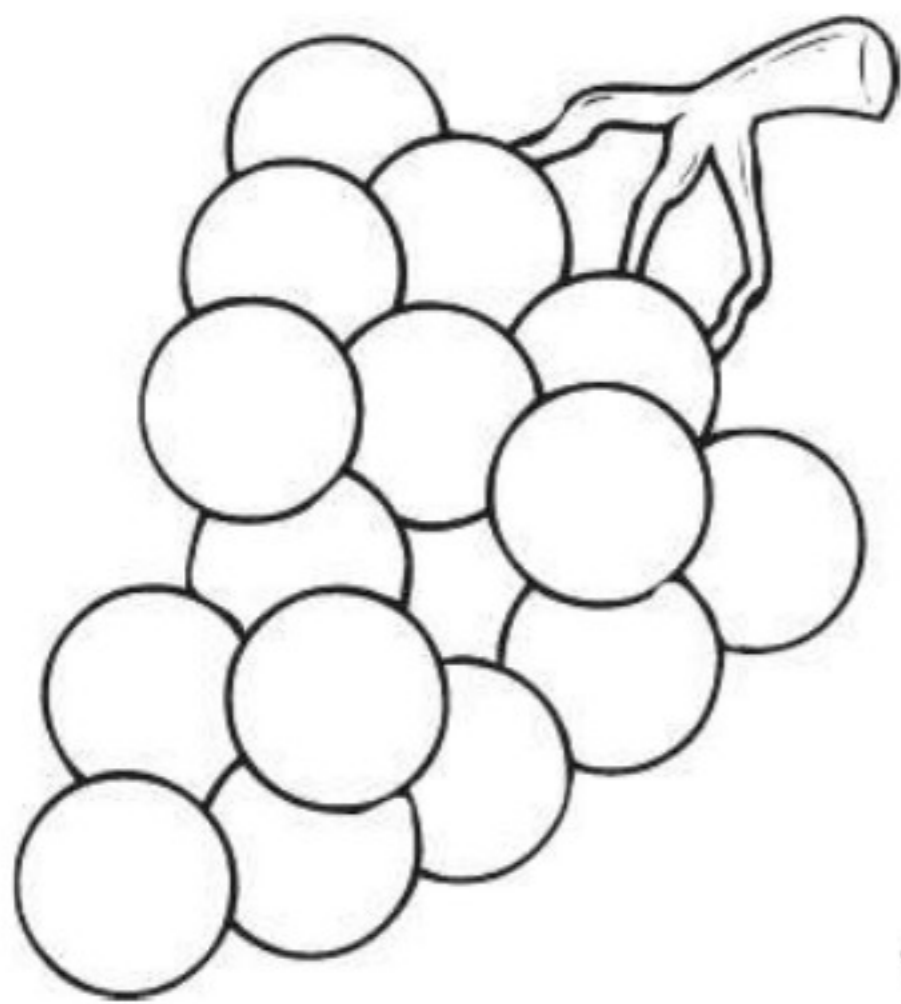

**Note to Parents:** Ask your child to name things that are purple.



# Color Orange Things

**Directions:** Color  Puppy's  **orange**.

Color  the pictures to match the .

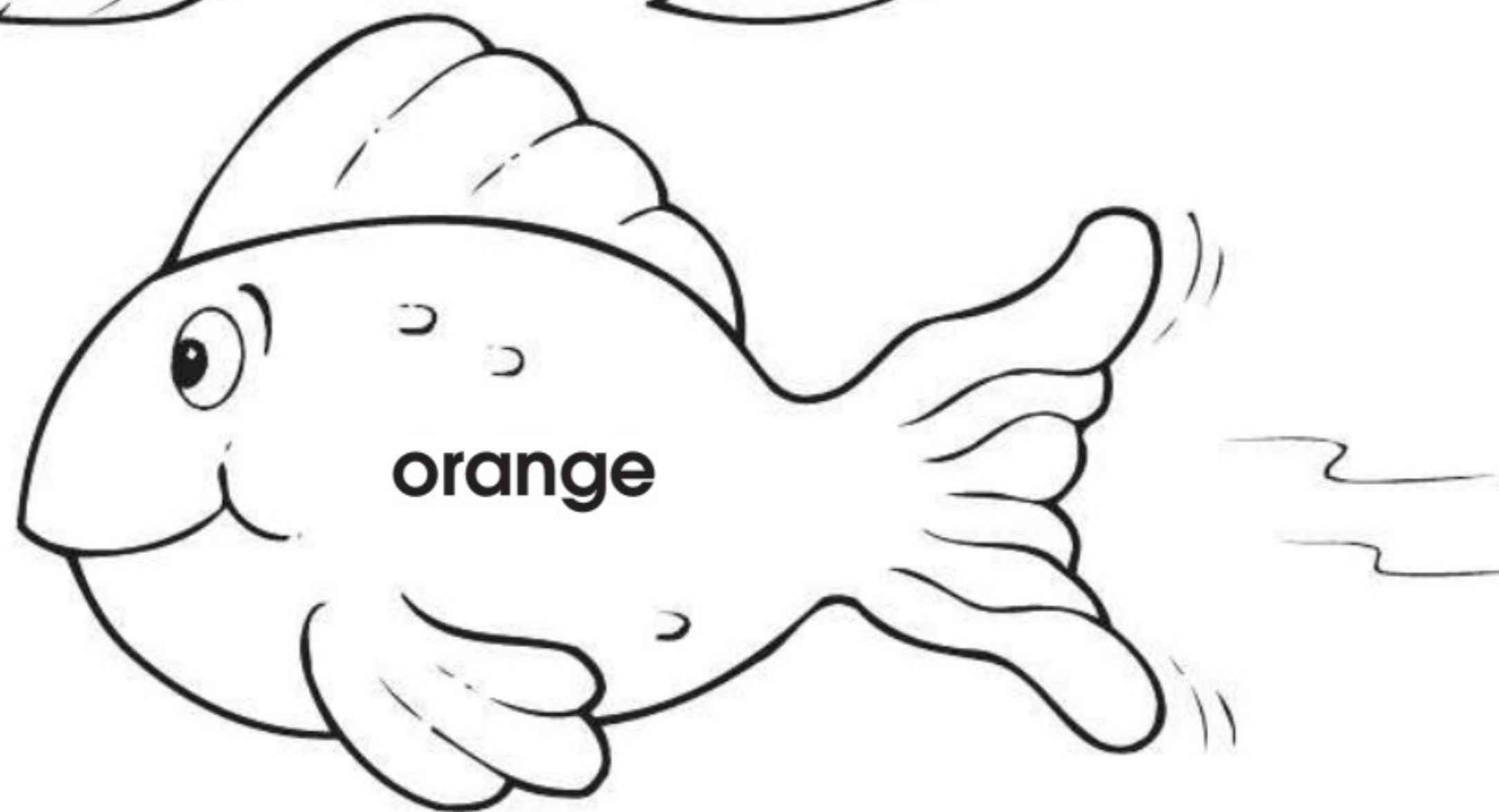
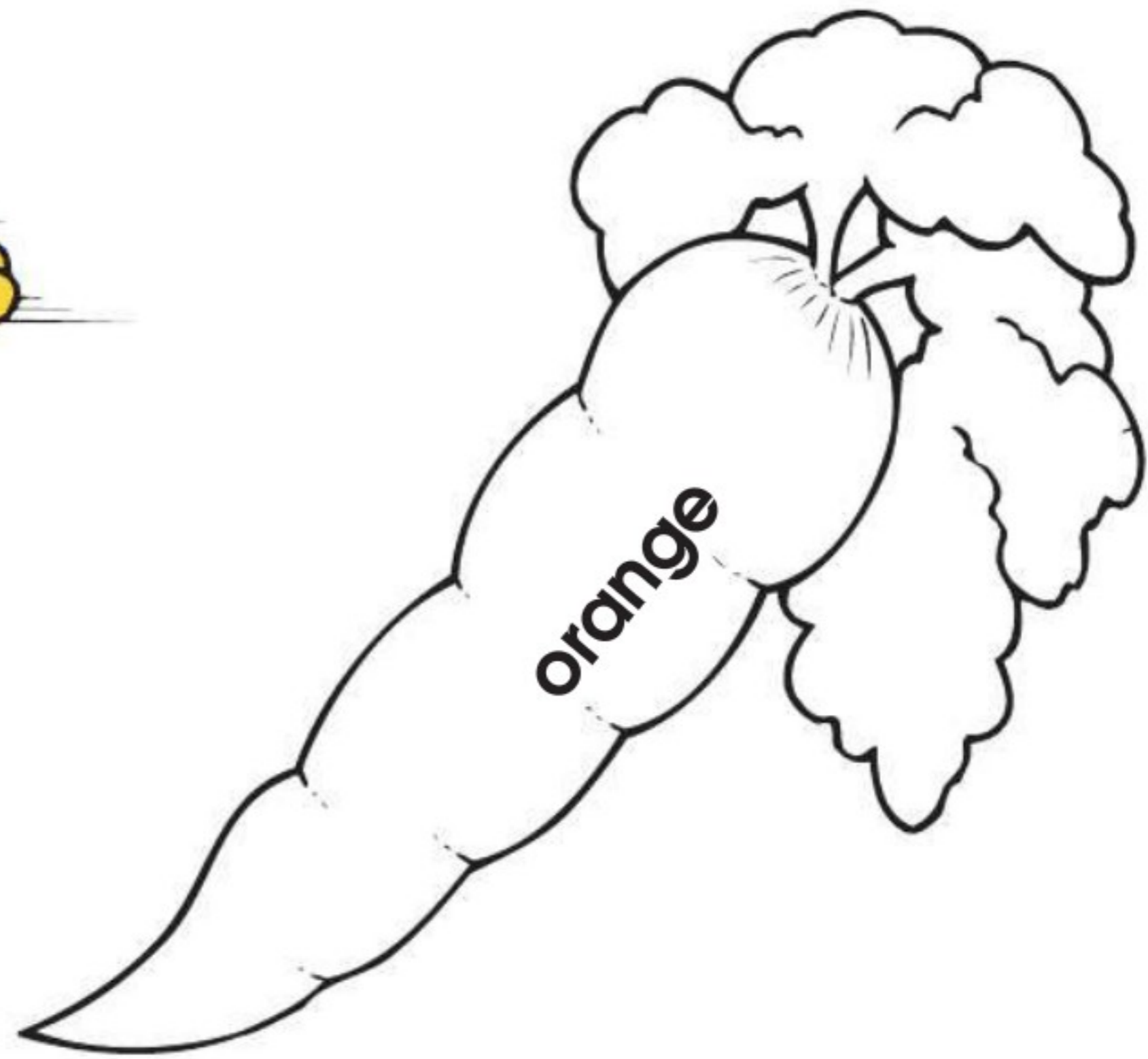
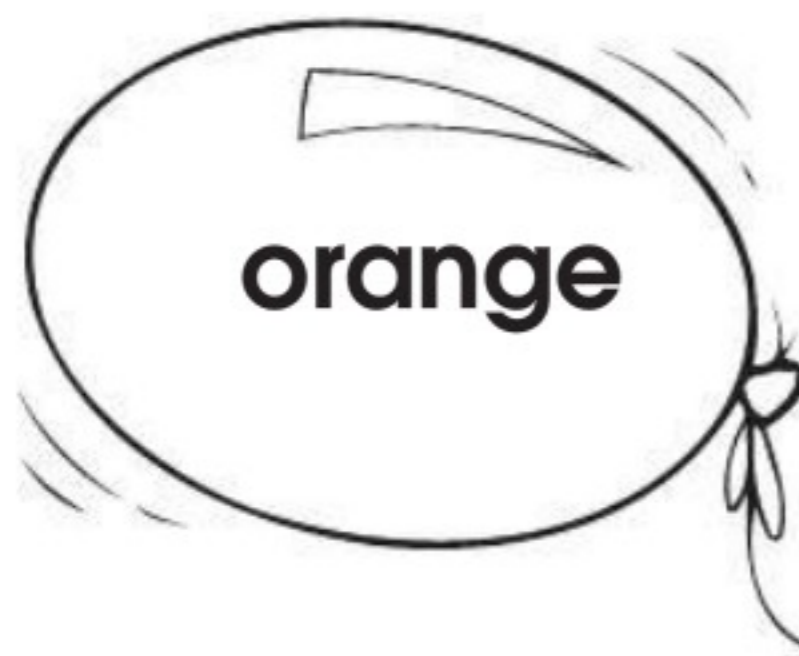

**Note to Parents:** Have a scavenger hunt in your home and gather orange items with your child.



## Trace and Write Orange

**Directions:** Trace  the word "orange" in the second box below. Then, in the third box, write  "orange" on your own.

orange

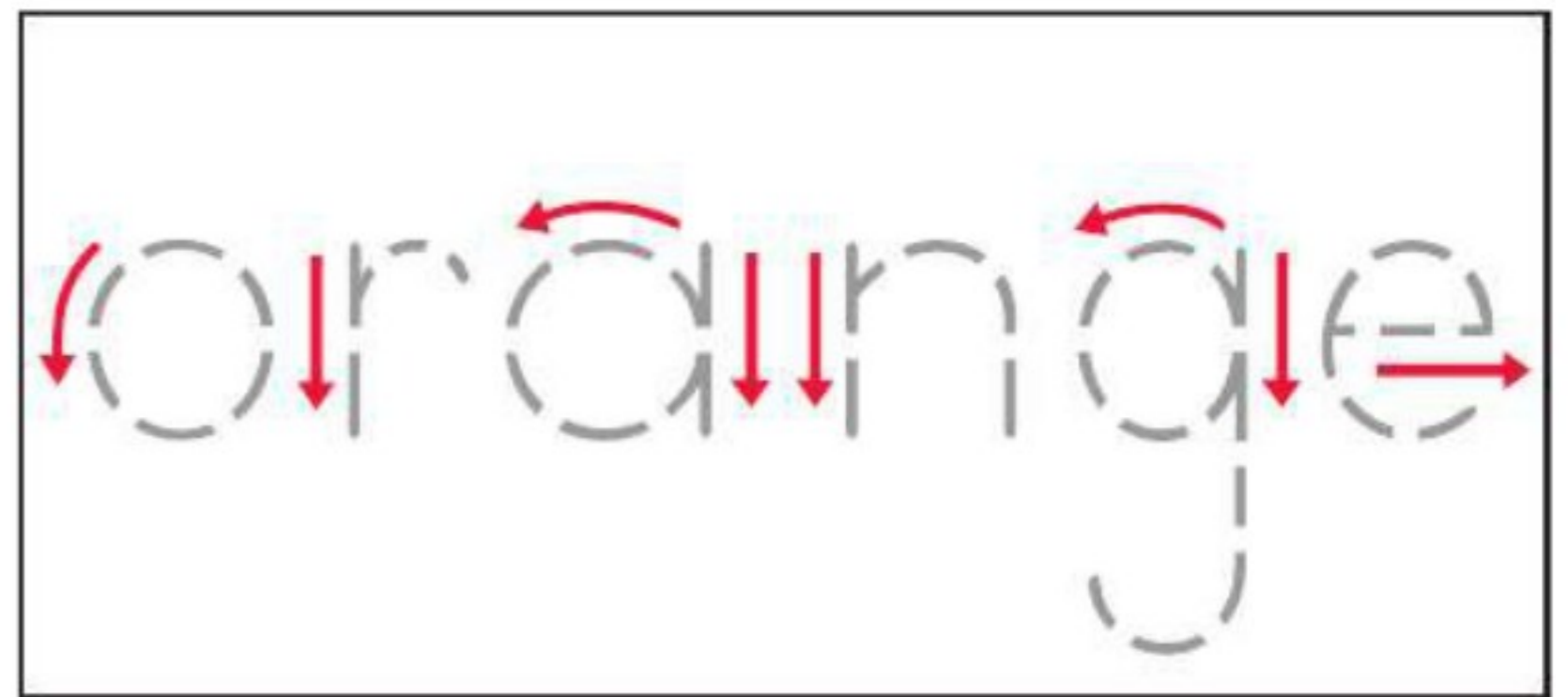

**Directions:** Which three could be orange? Color  with orange.

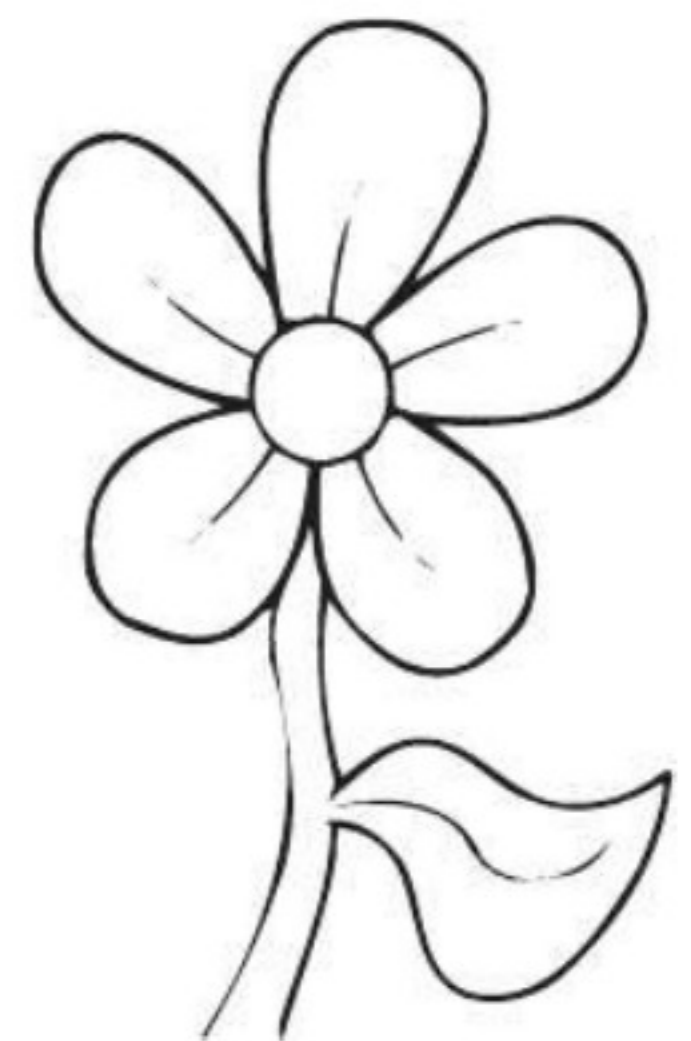
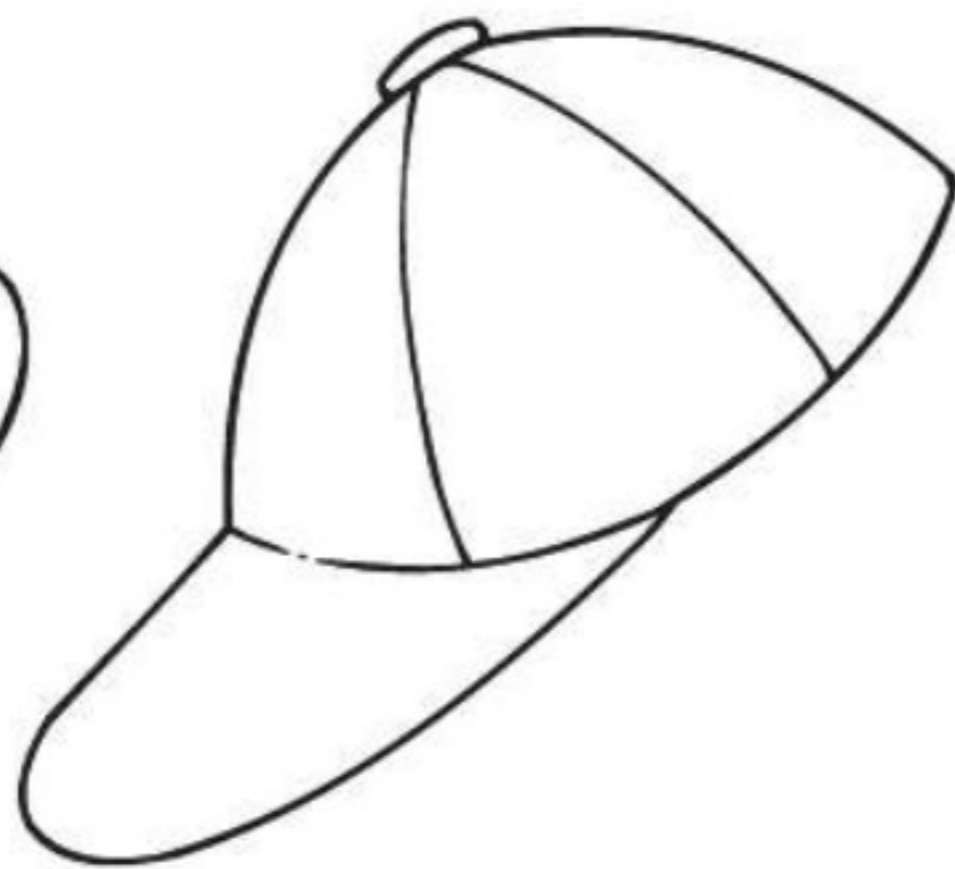
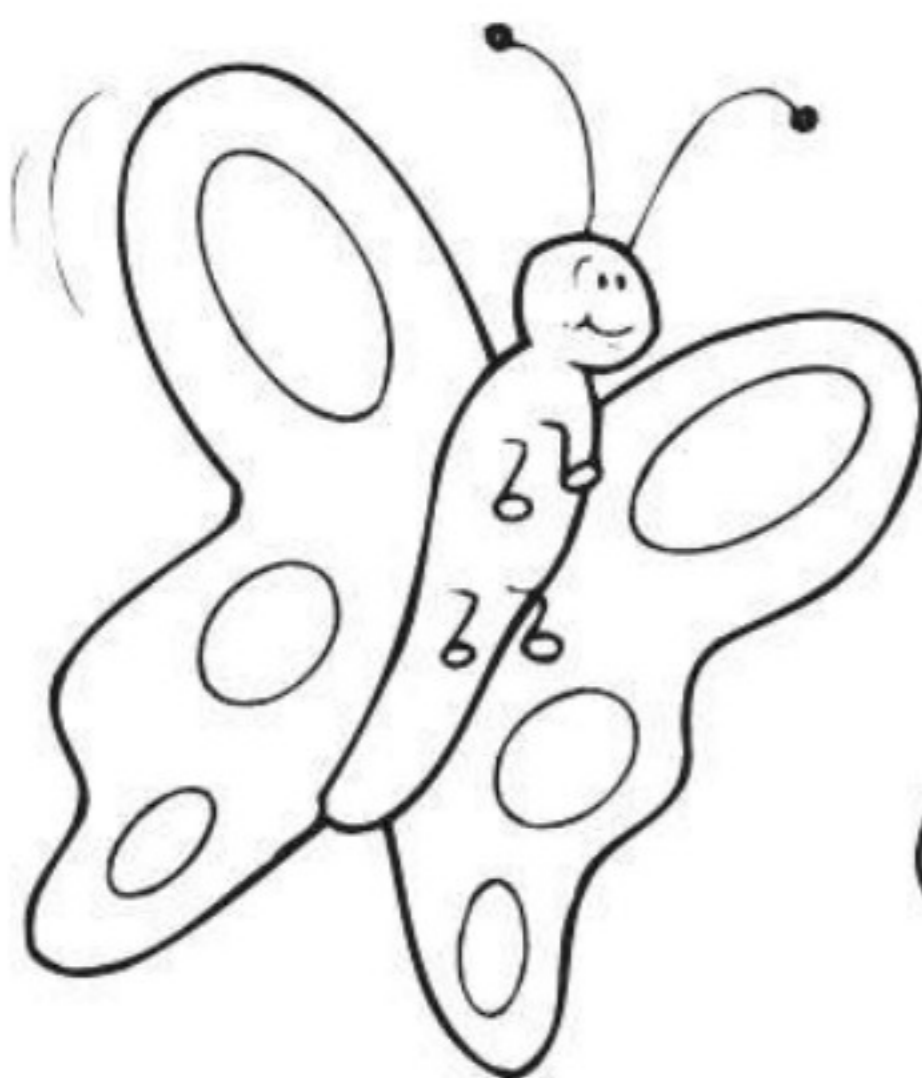

**Note to Parents:** Ask your child to name things that are orange.



# Color Black Things

**Directions:** Color  Penguin's  **black**.

Color  the pictures to match the .

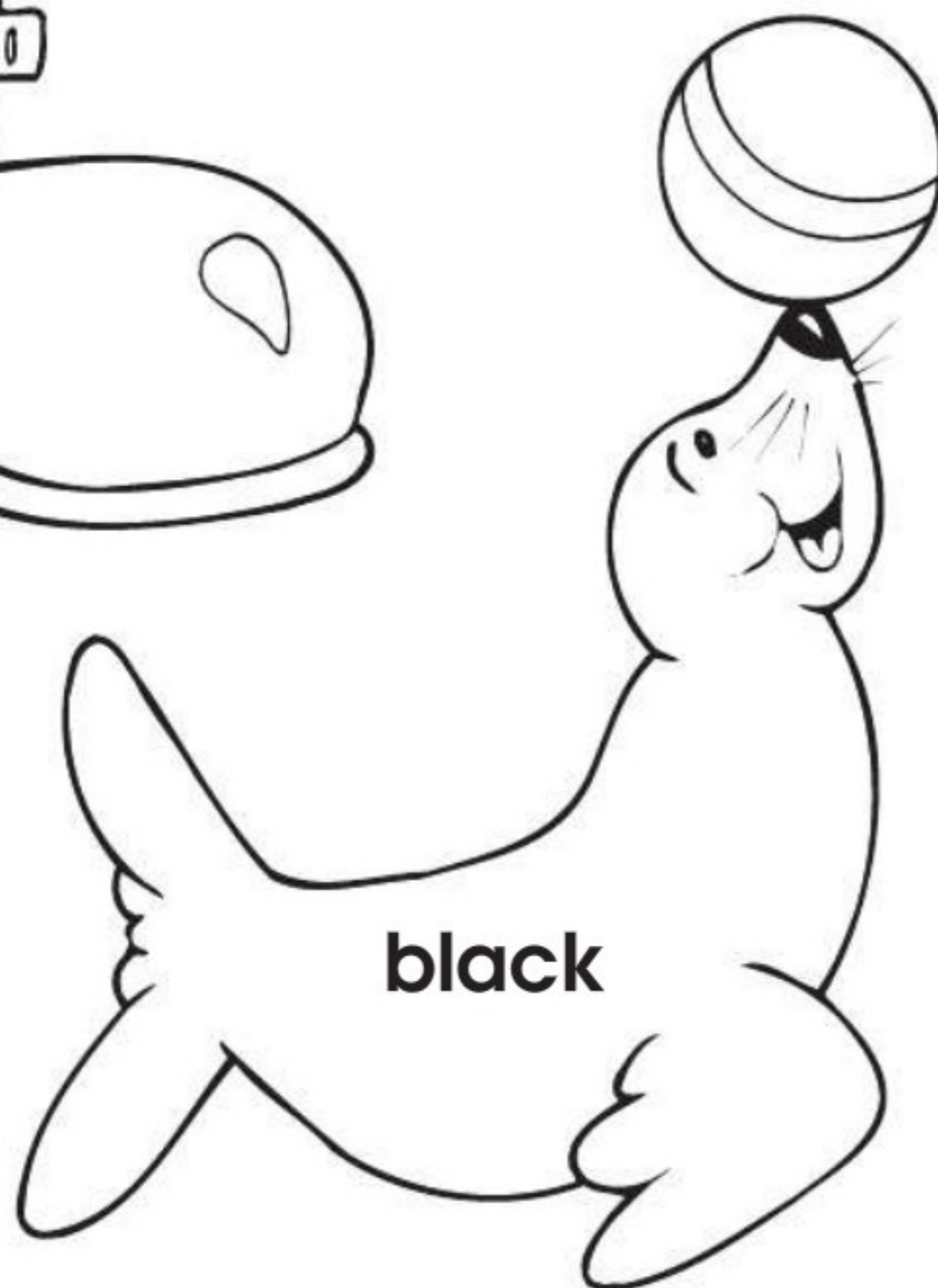
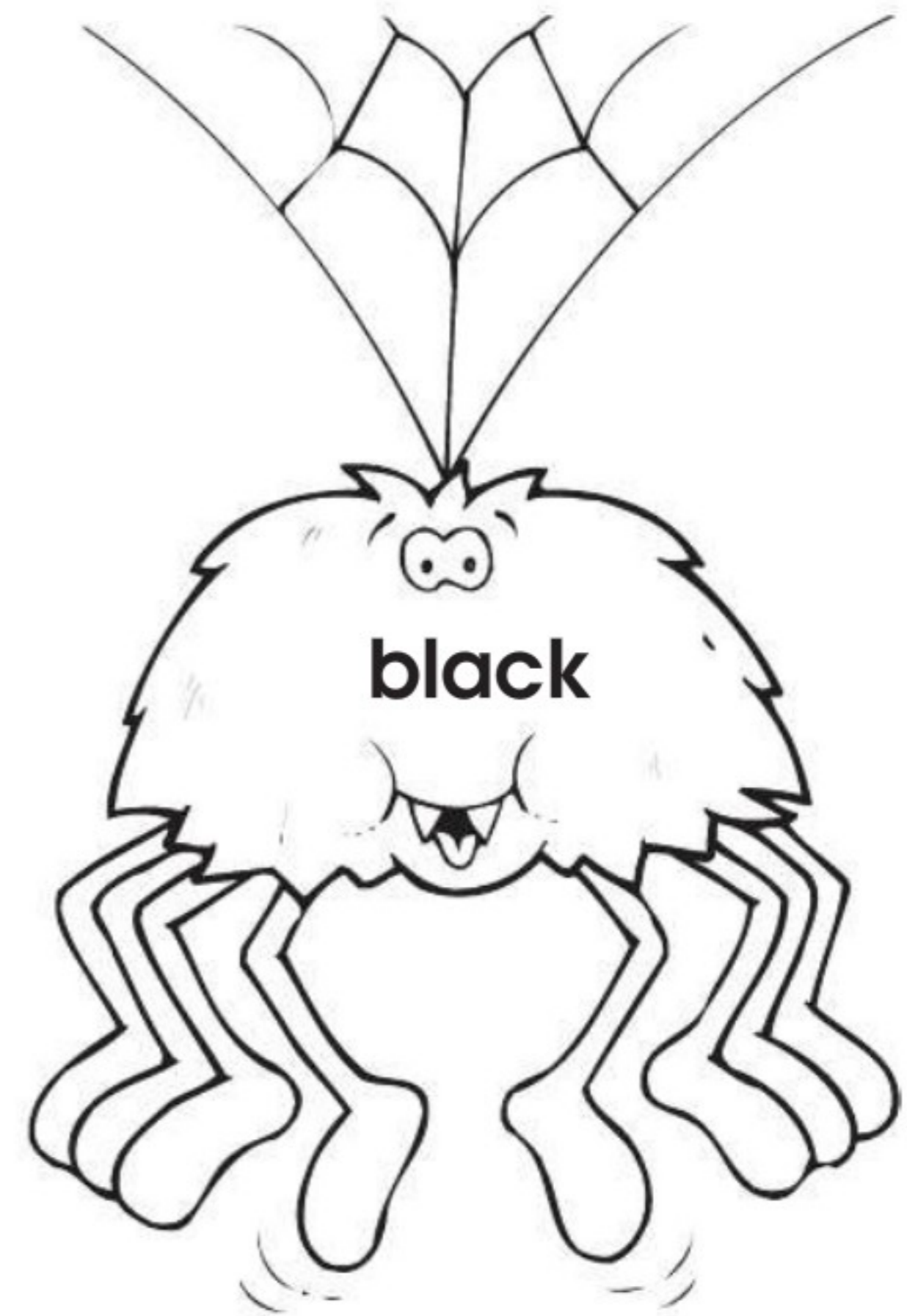
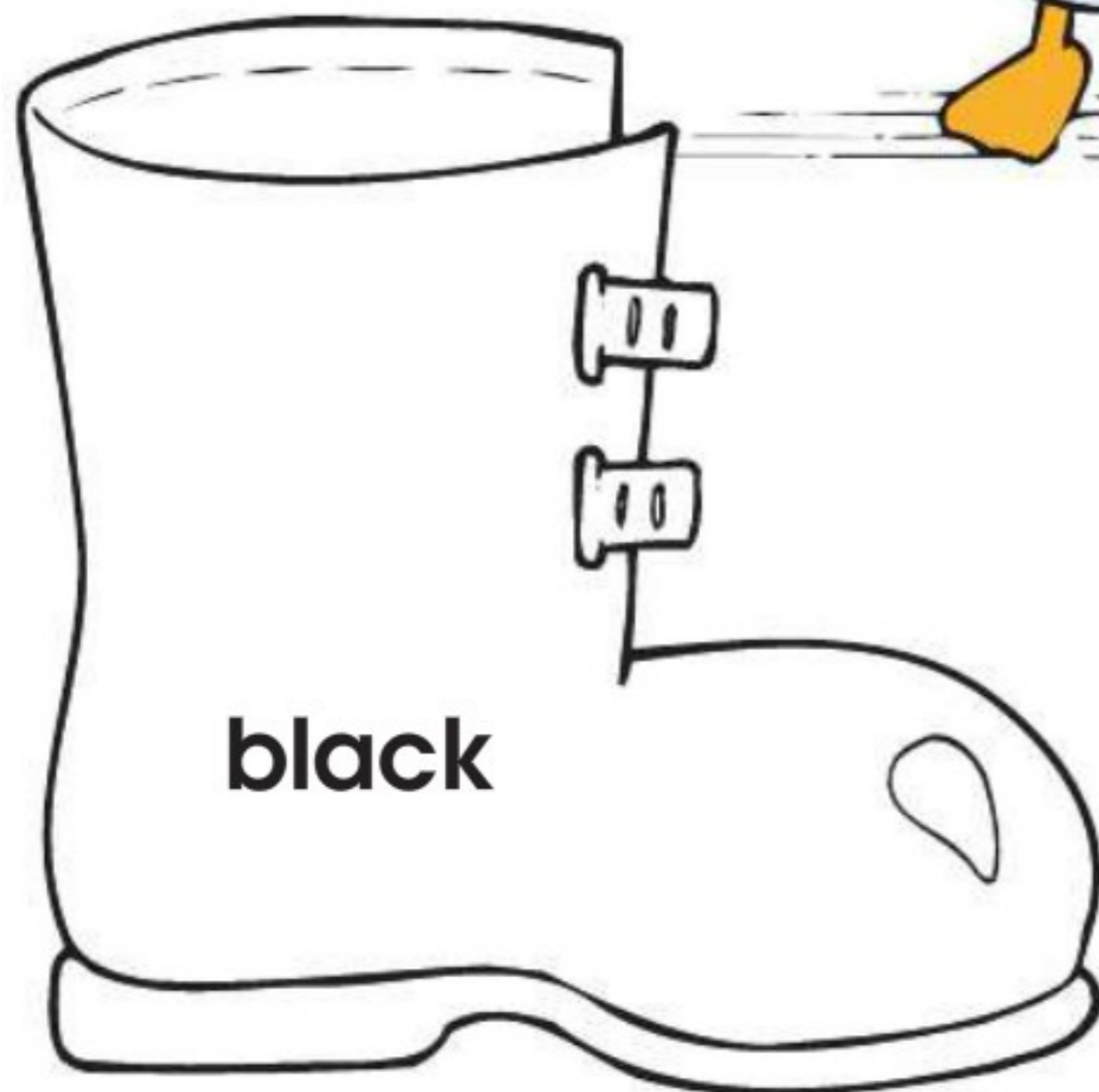
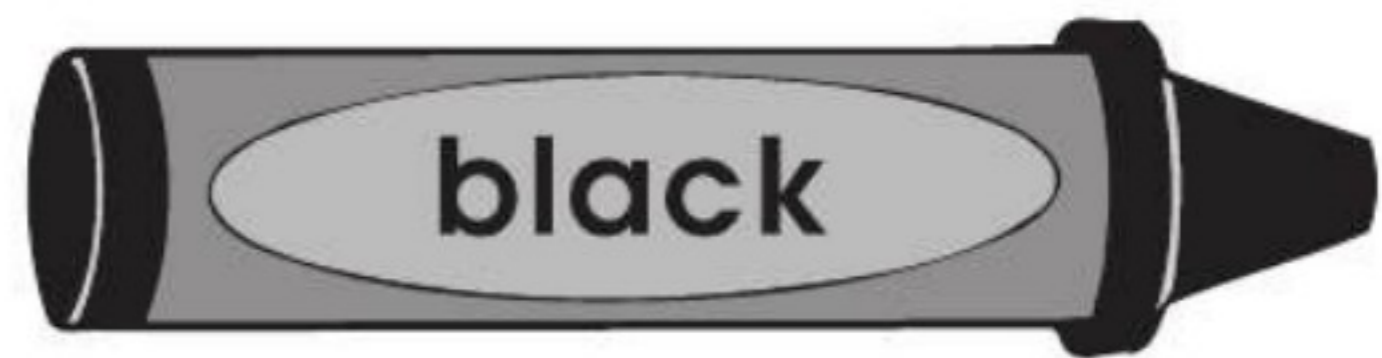
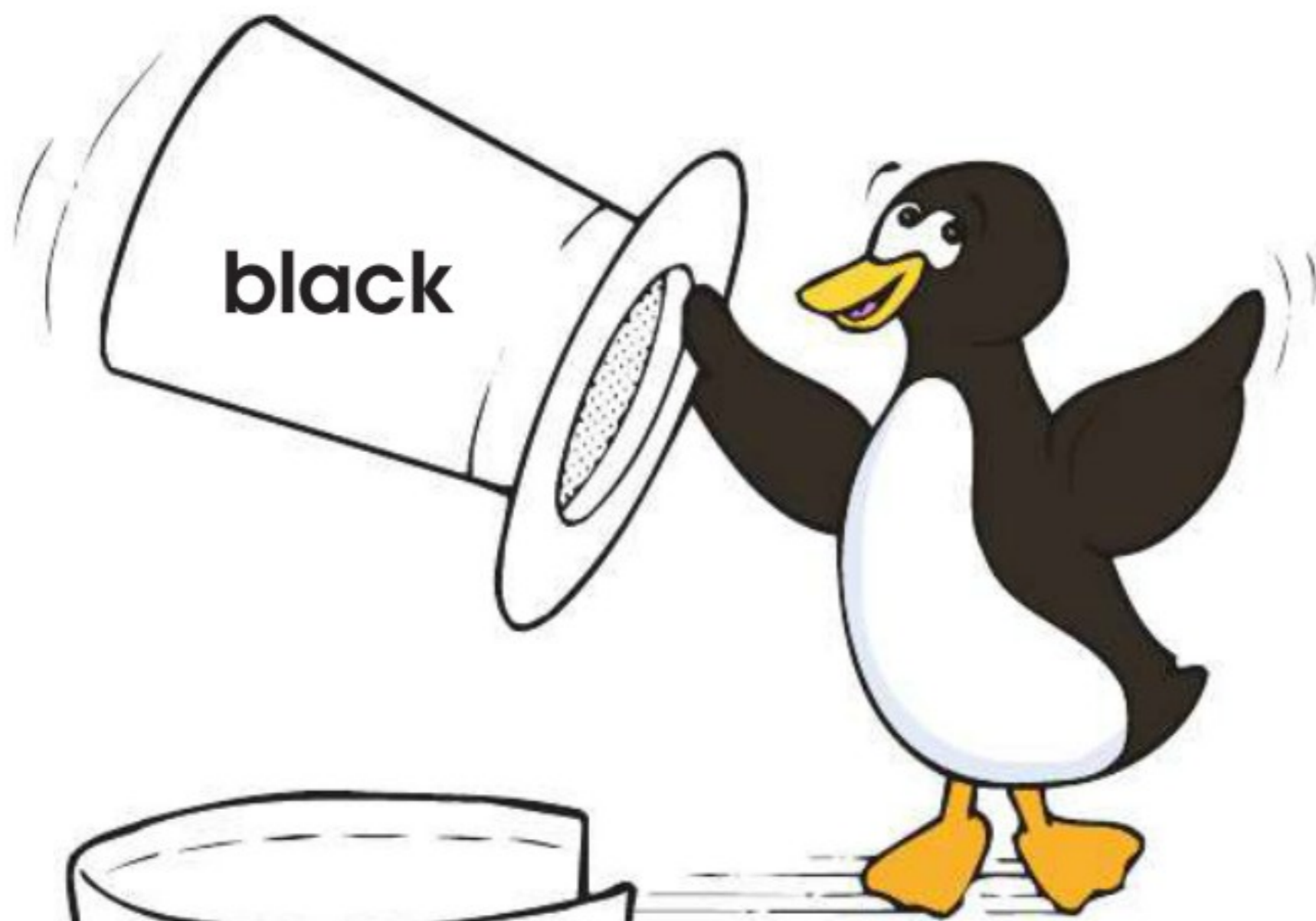

**Note to Parents:** Have a scavenger hunt in your home and gather black items with your child.



## Trace and Write Black

**Directions:** Trace  the word "black" in the second box below. Then, in the third box, write  "black" on your own.

black

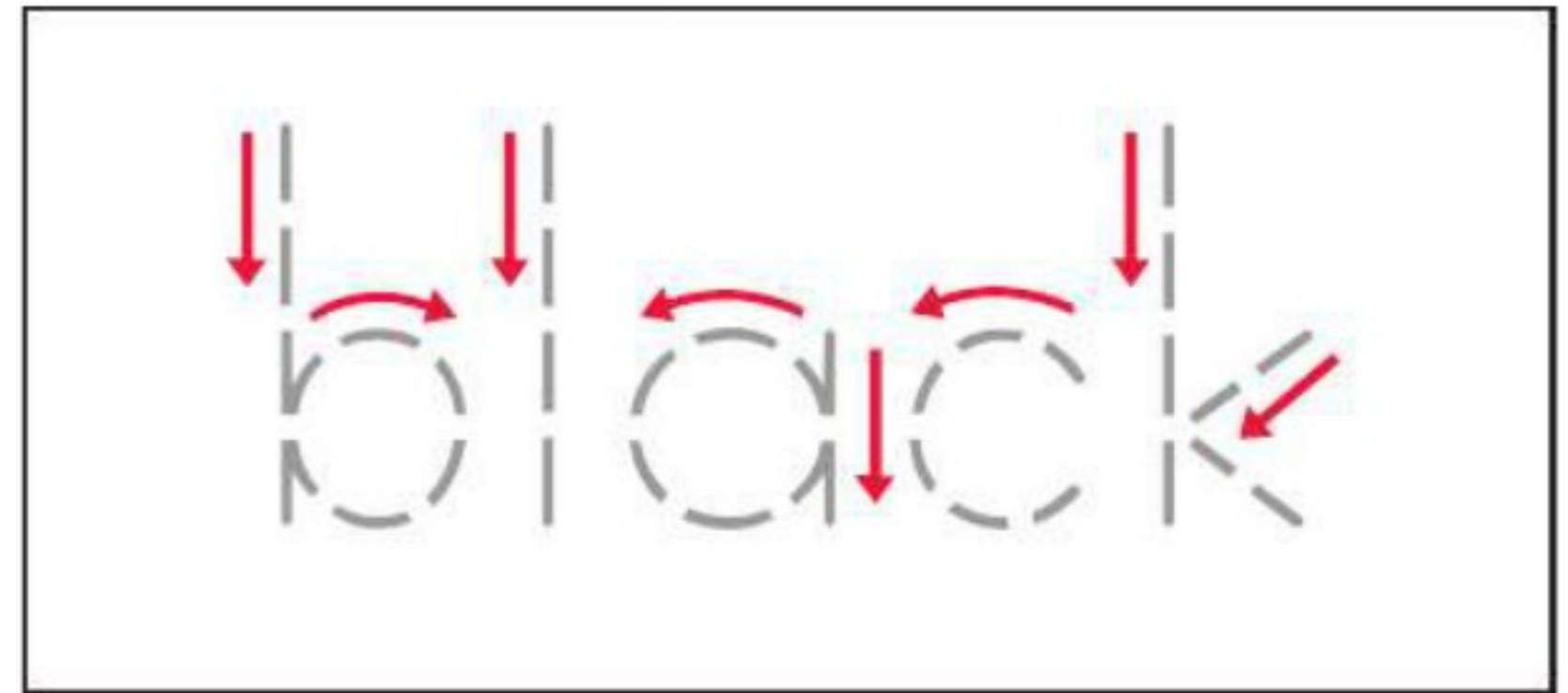

**Directions:** Which three could be black? Color  with black.

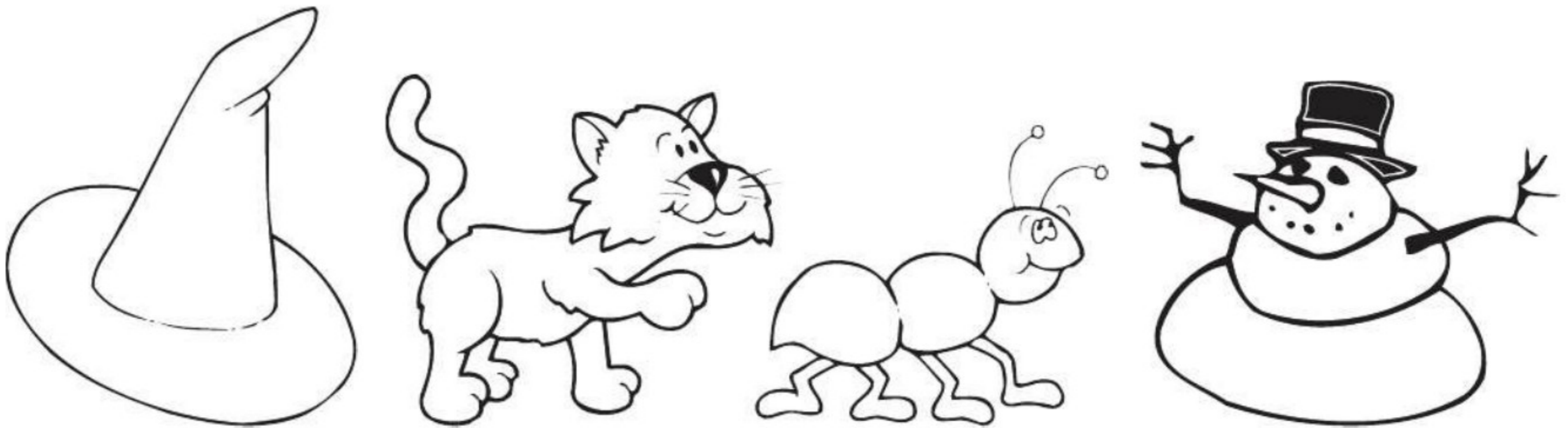

**Note to Parents:** Ask your child to name things that are black.



# Color Review

**Directions:** Color  each picture the correct color.

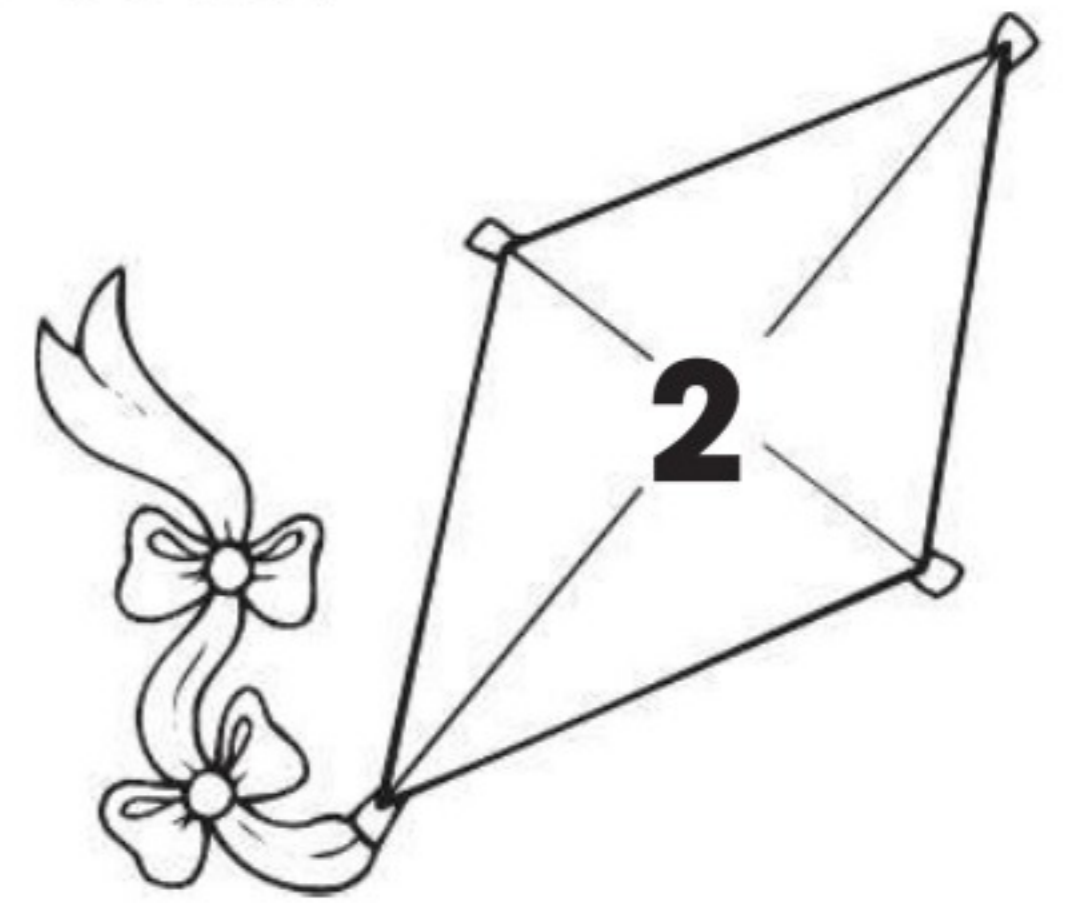
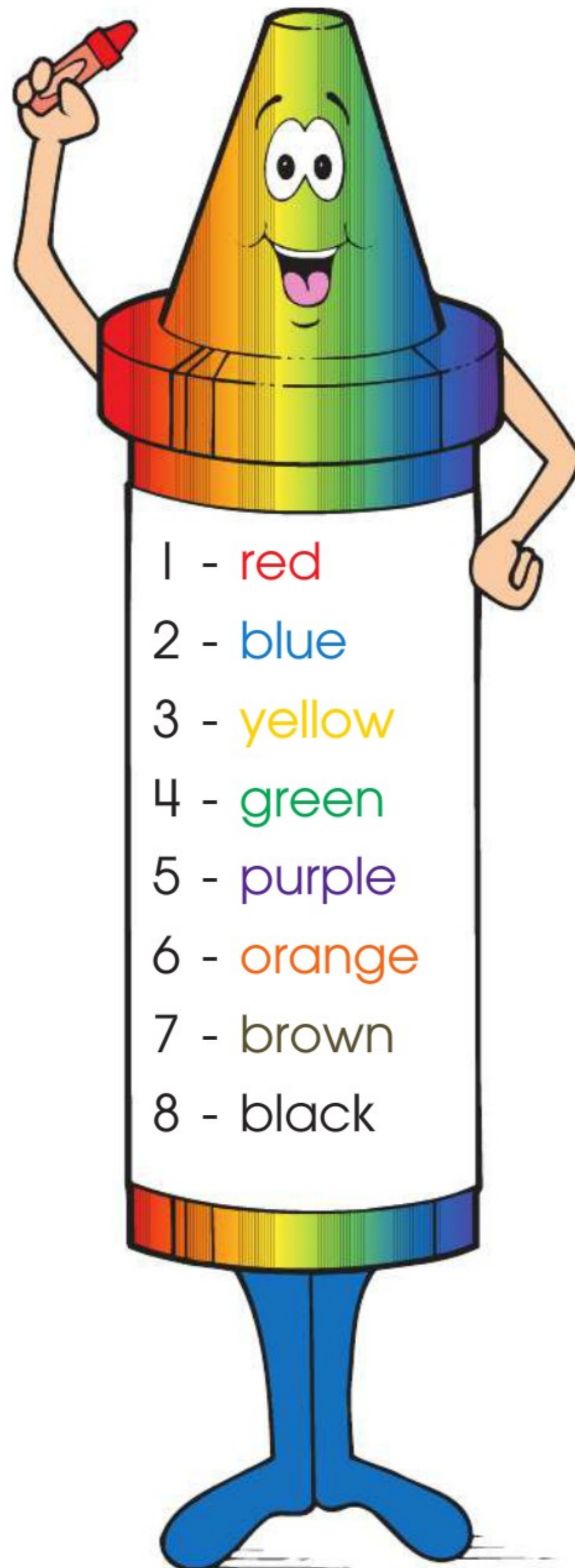
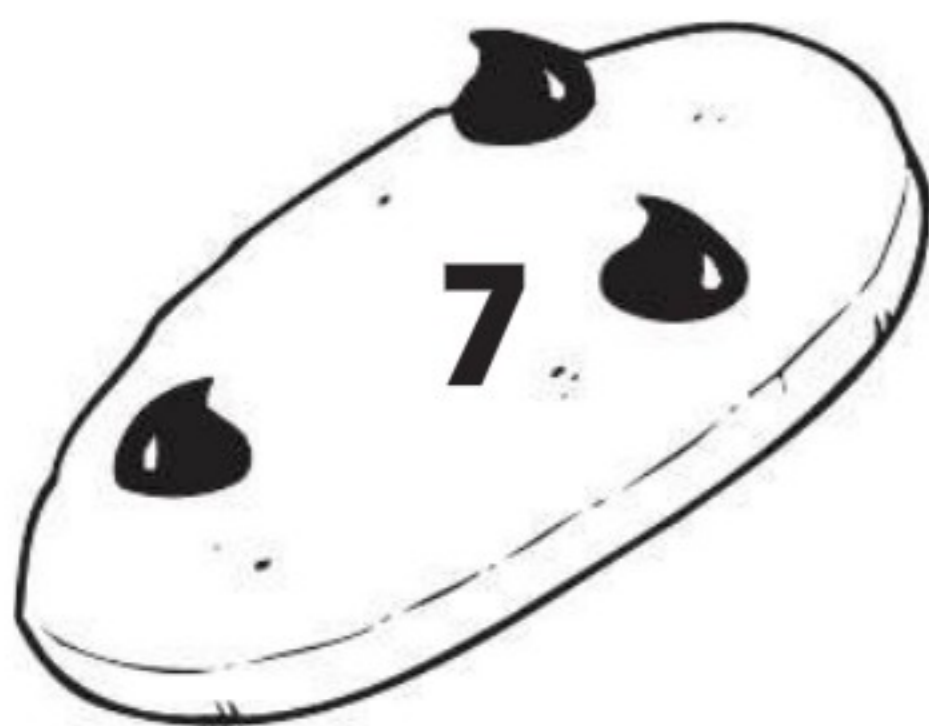
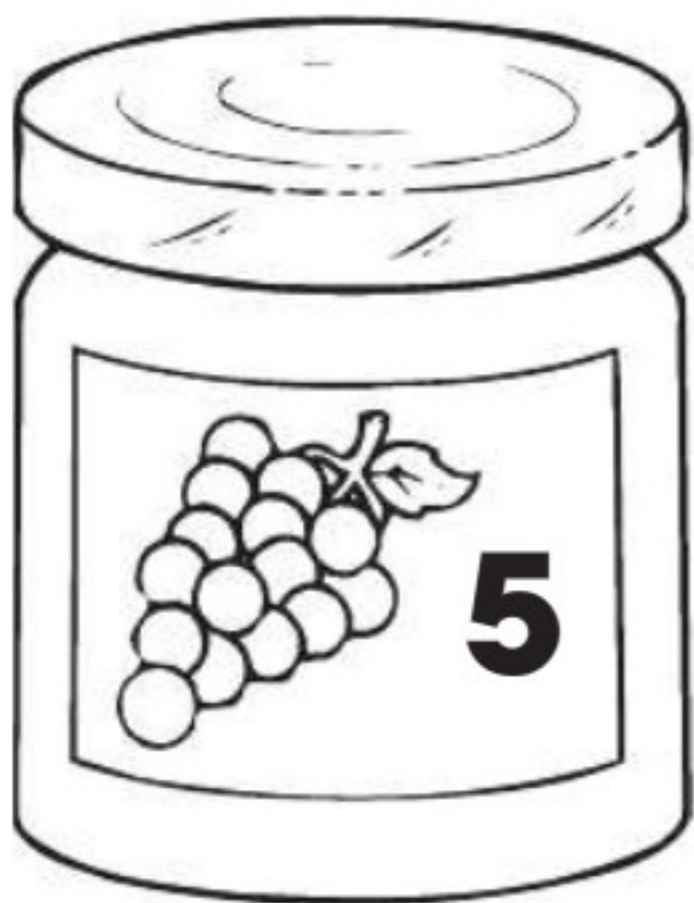
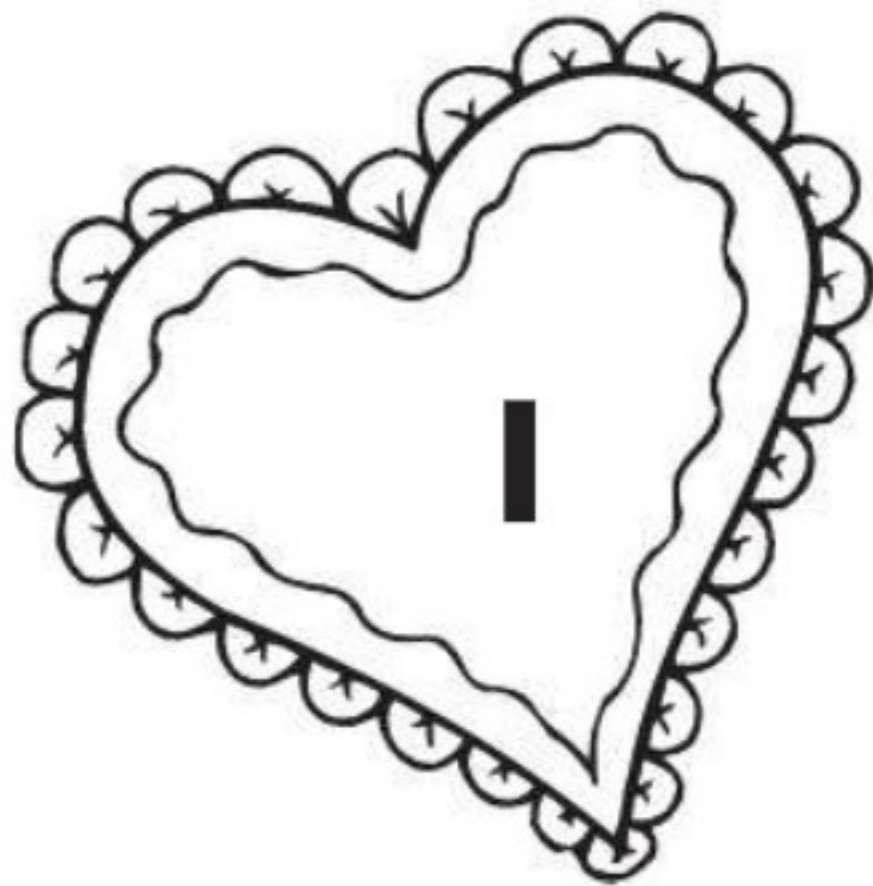
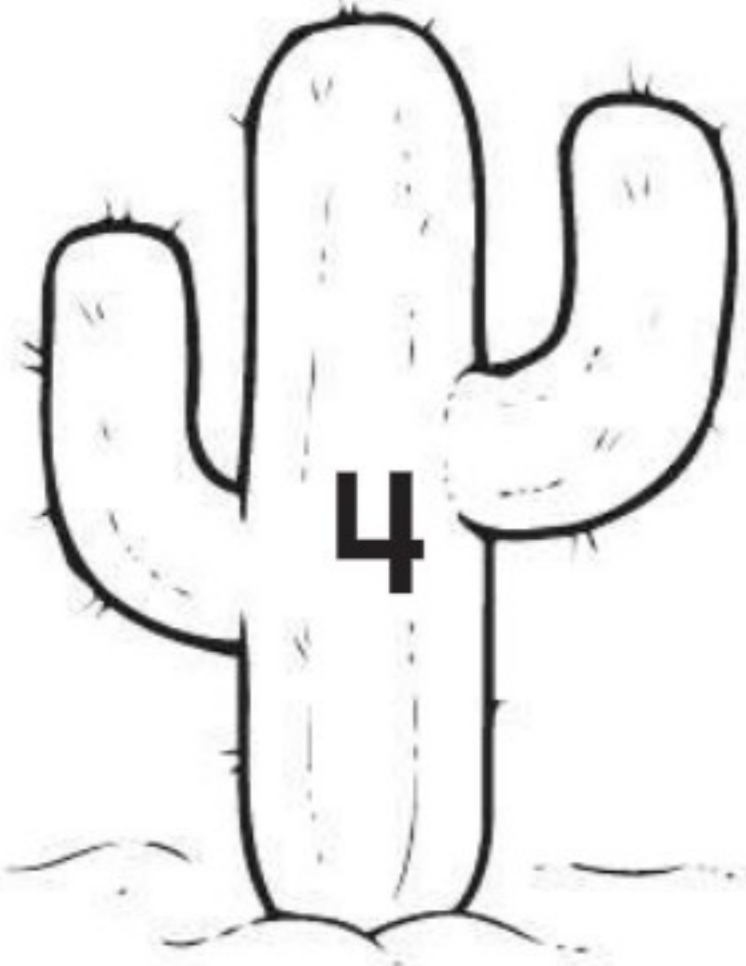



# Color Review

**Directions:** Color  each . Color  the  too!

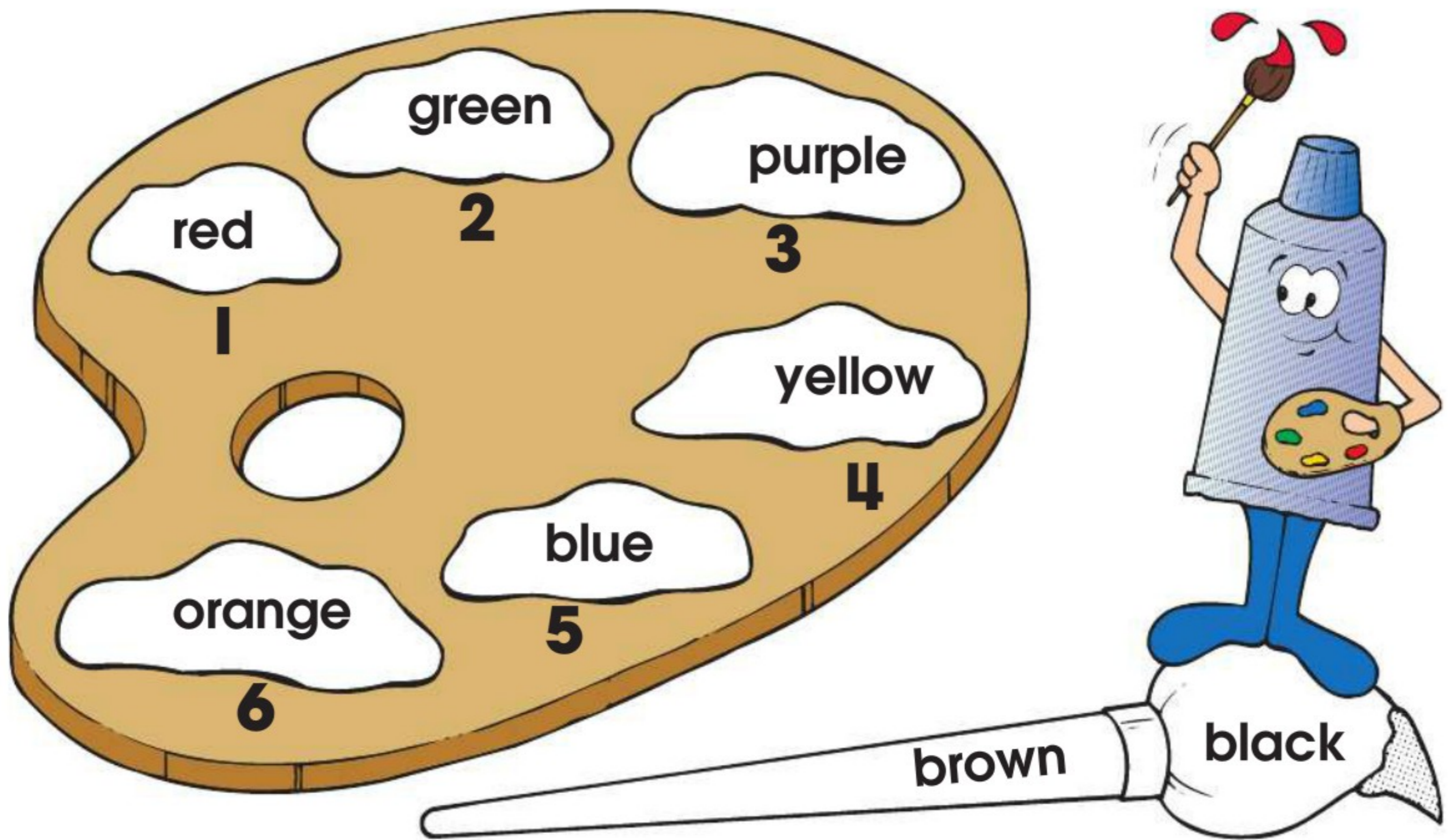

**Directions:** Use each color from the  to color  the pictures. Color  the  to match.

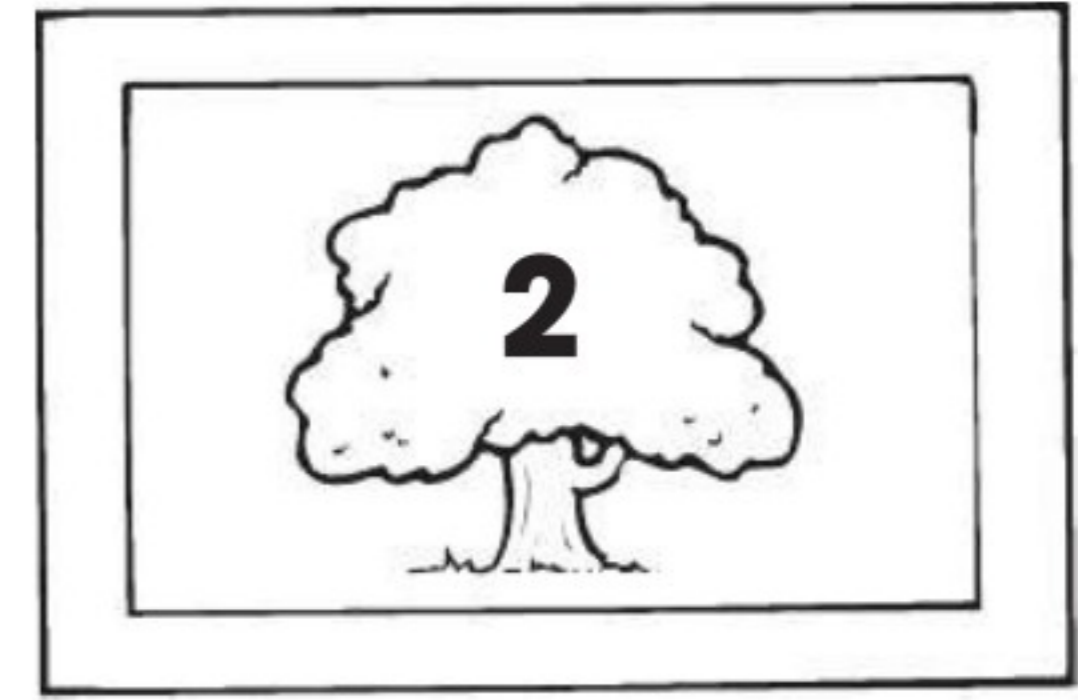
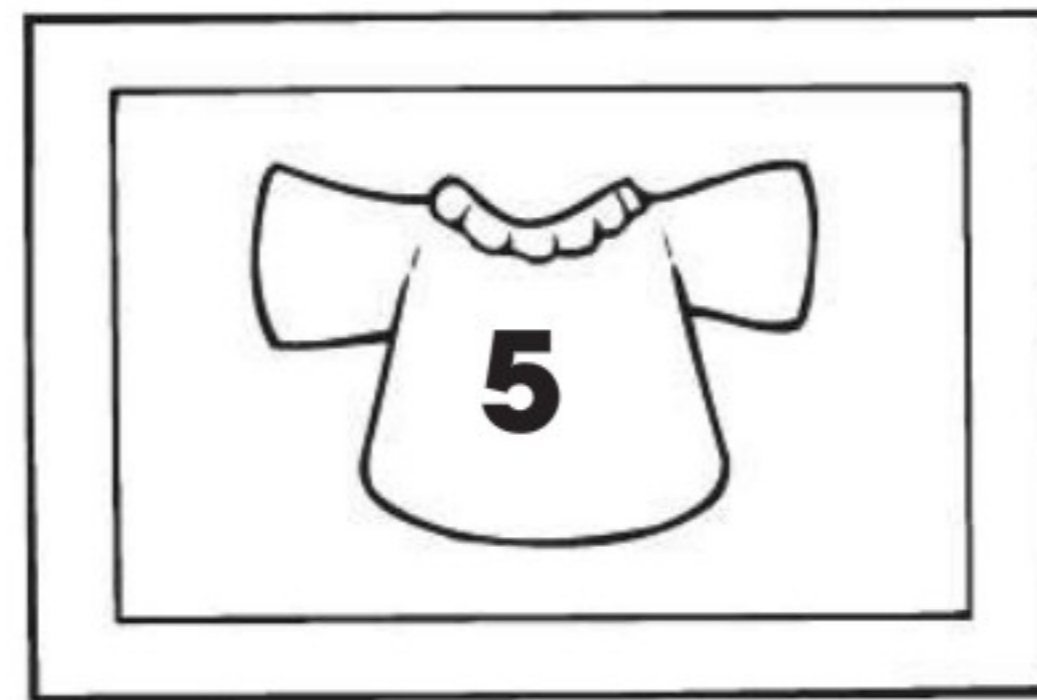
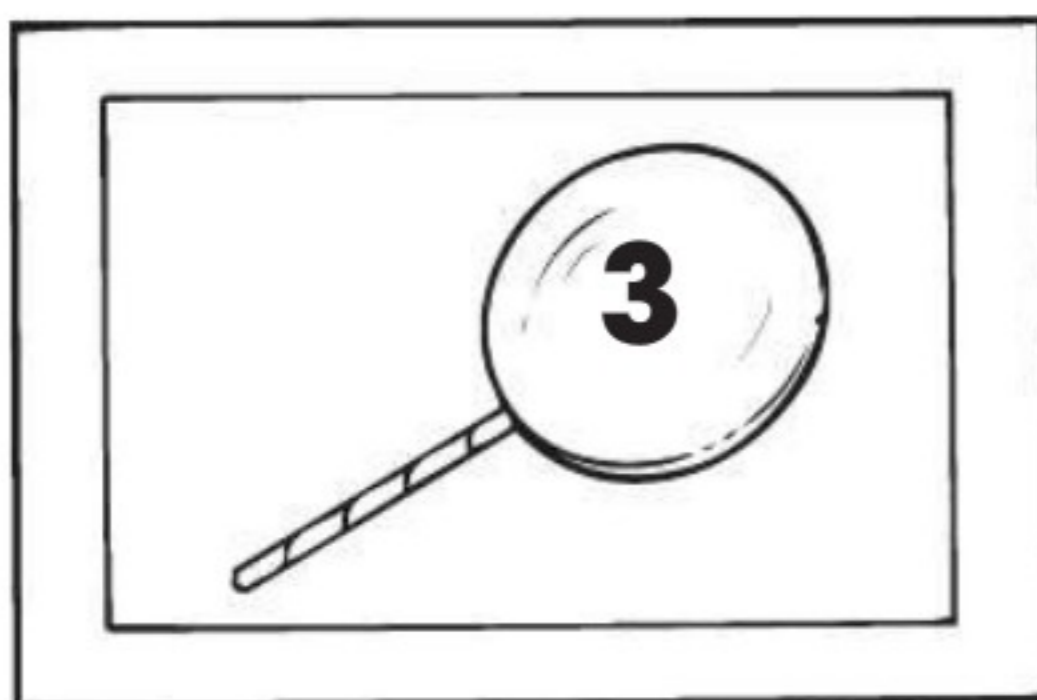
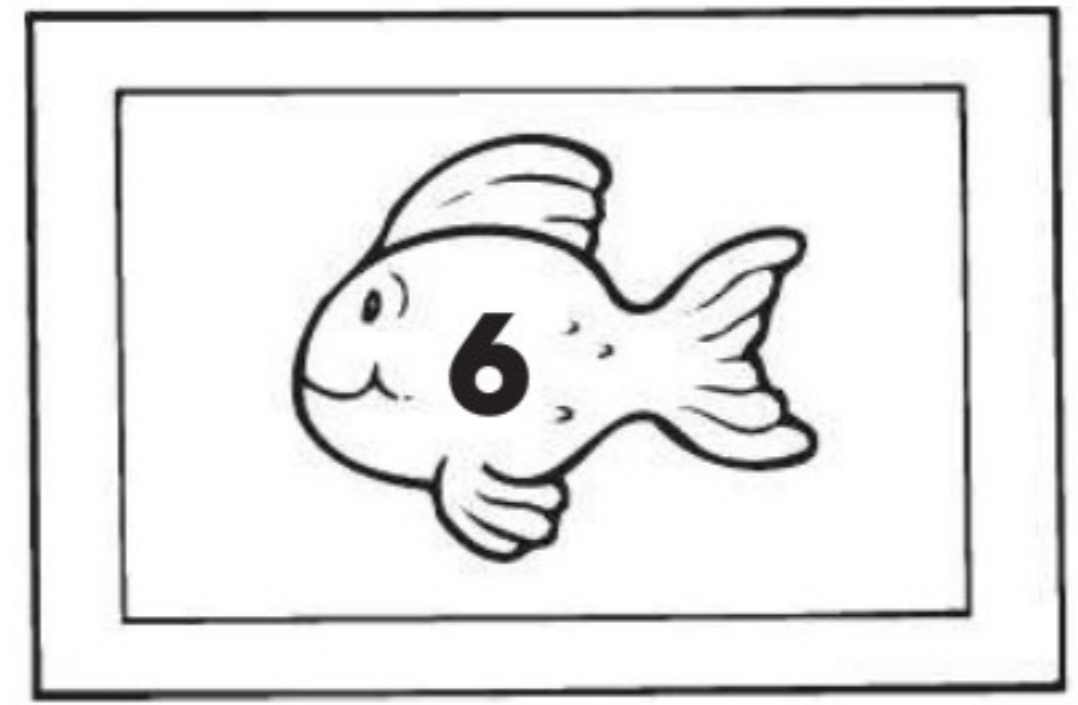
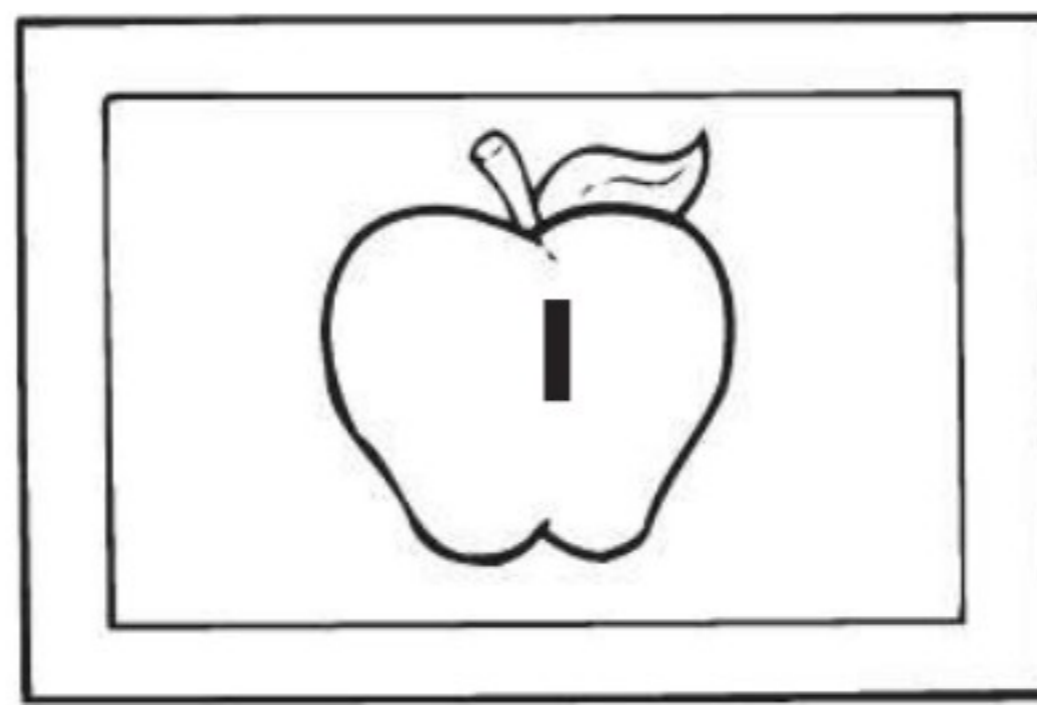
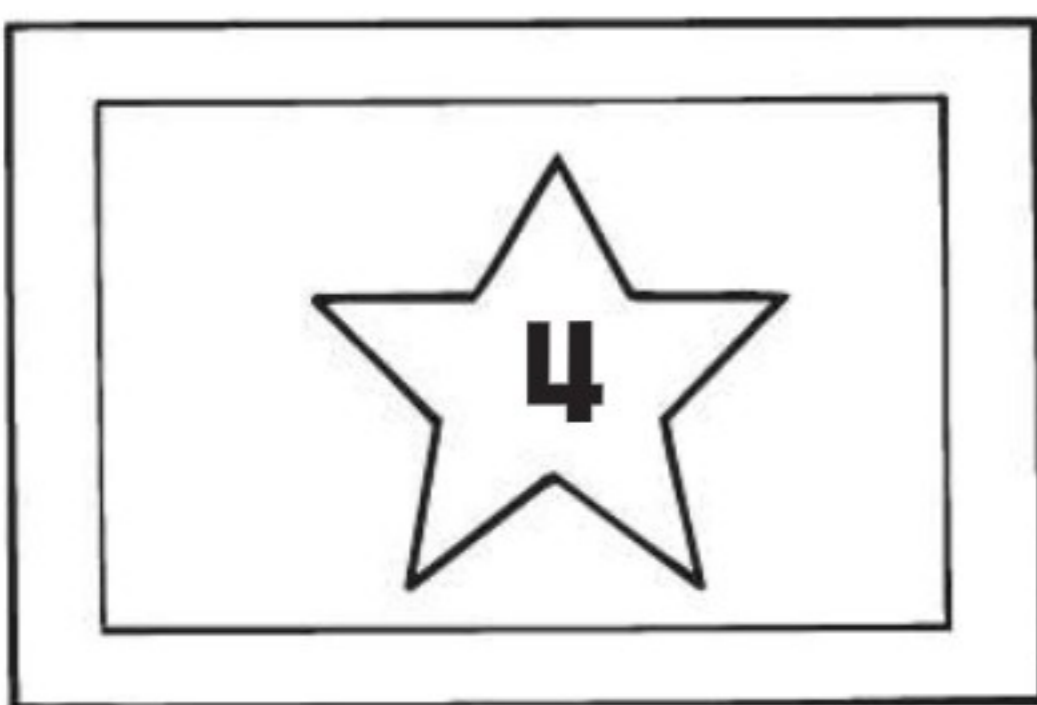



# Trace and Write Circles

**Directions:** This is a circle: ○. **Trace**  and **color**  each circle the correct color.

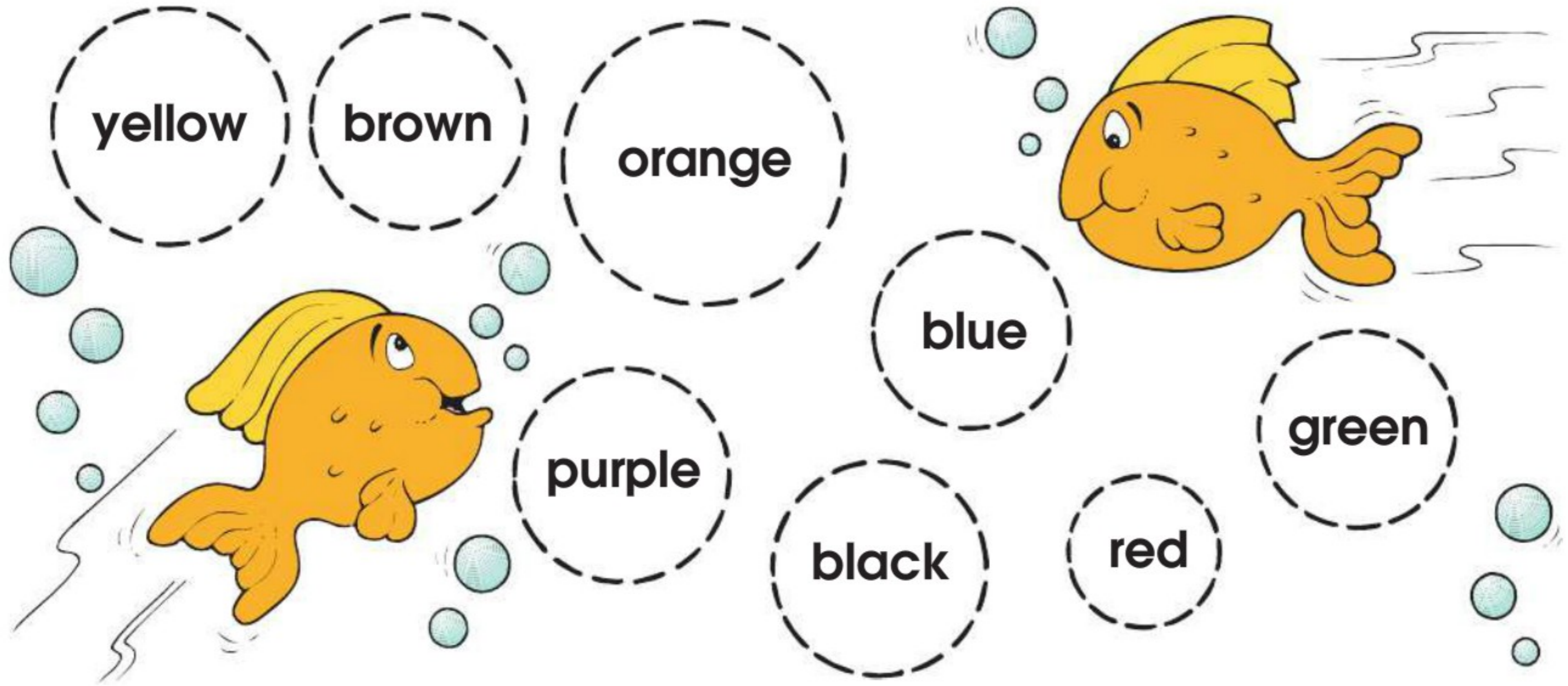

**Directions:** **Trace**  the word "circle" in the second box below. Then, in the third box, **write**  "circle" on your own.

circle

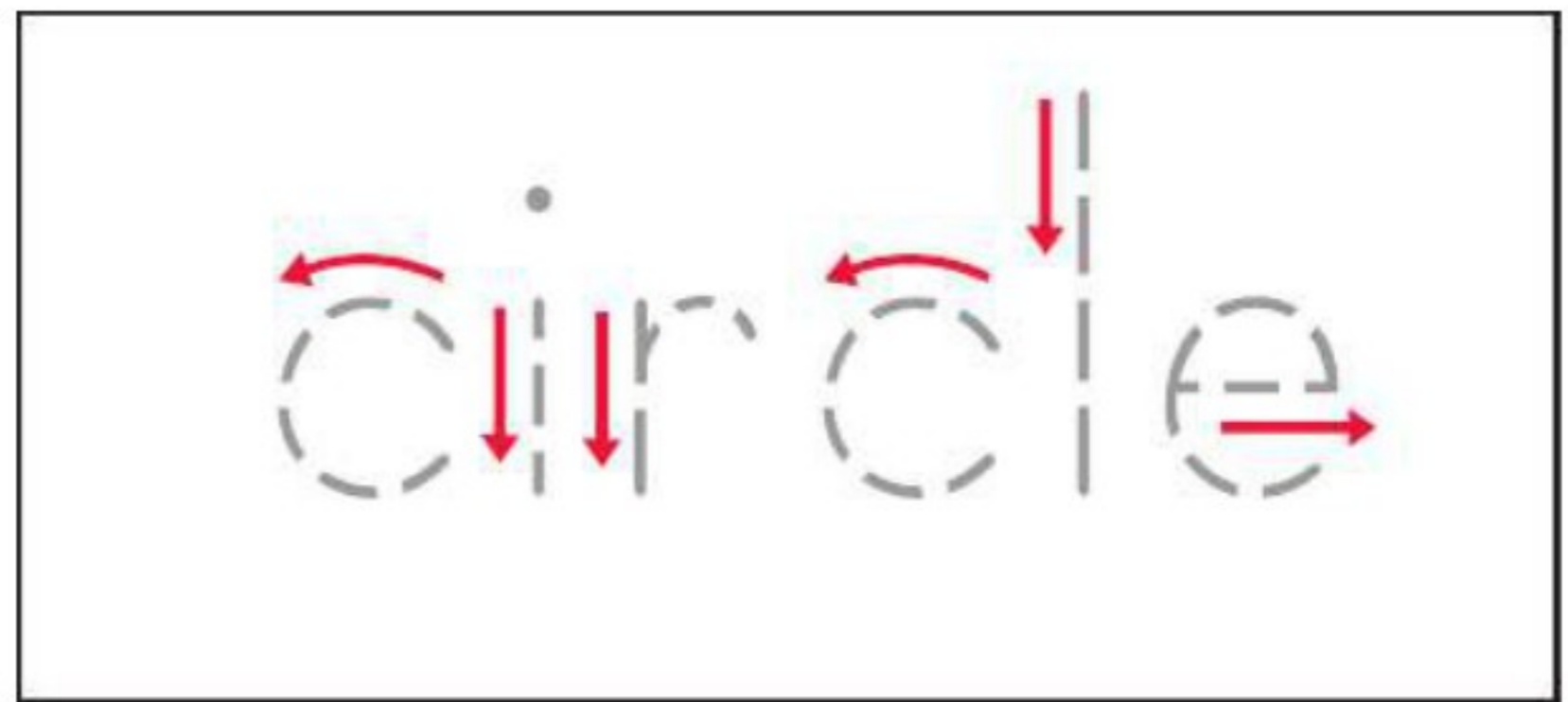



Name \_\_\_\_\_



## Color and Draw Circles

**Directions:** Circles can be different sizes. **Trace**  the circles. Find all the circles and **color**  them.

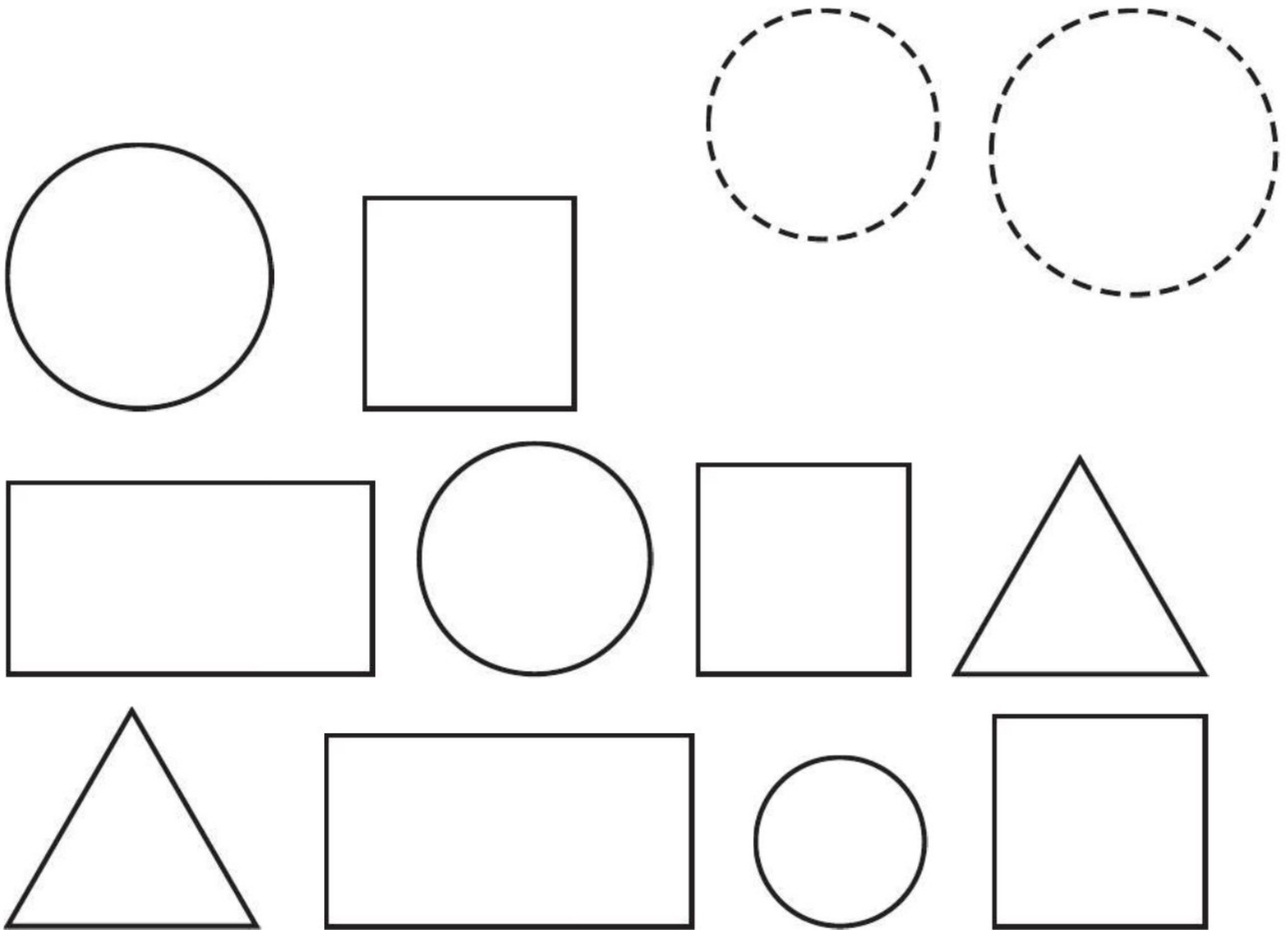



**Directions:** Now, **draw**  your own circles.

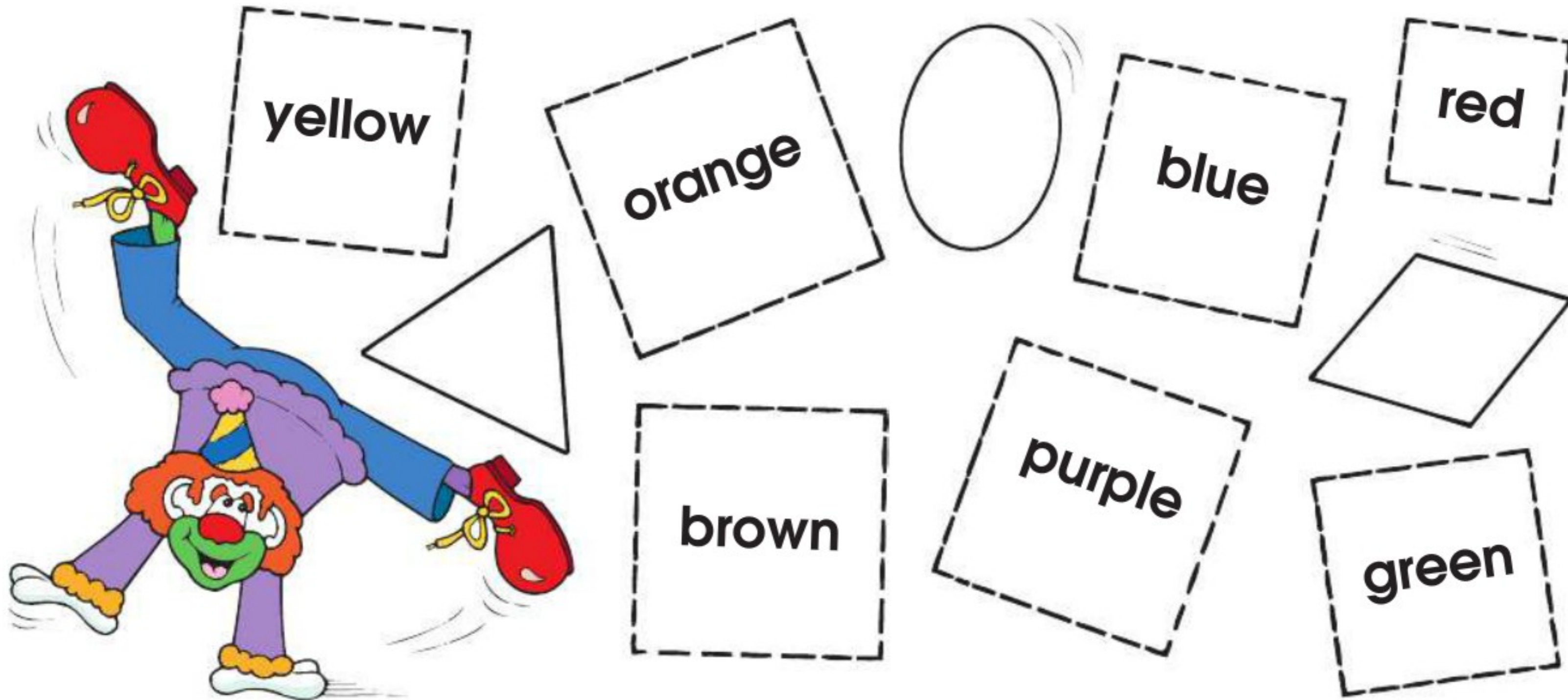

# Trace and Write Squares

**Directions:** This is a square: . **Trace**  and **color**  each square the correct color.



**Directions:** **Trace**  the word "square" in the second box below. Then, in the third box, **write**  "square" on your own.

square

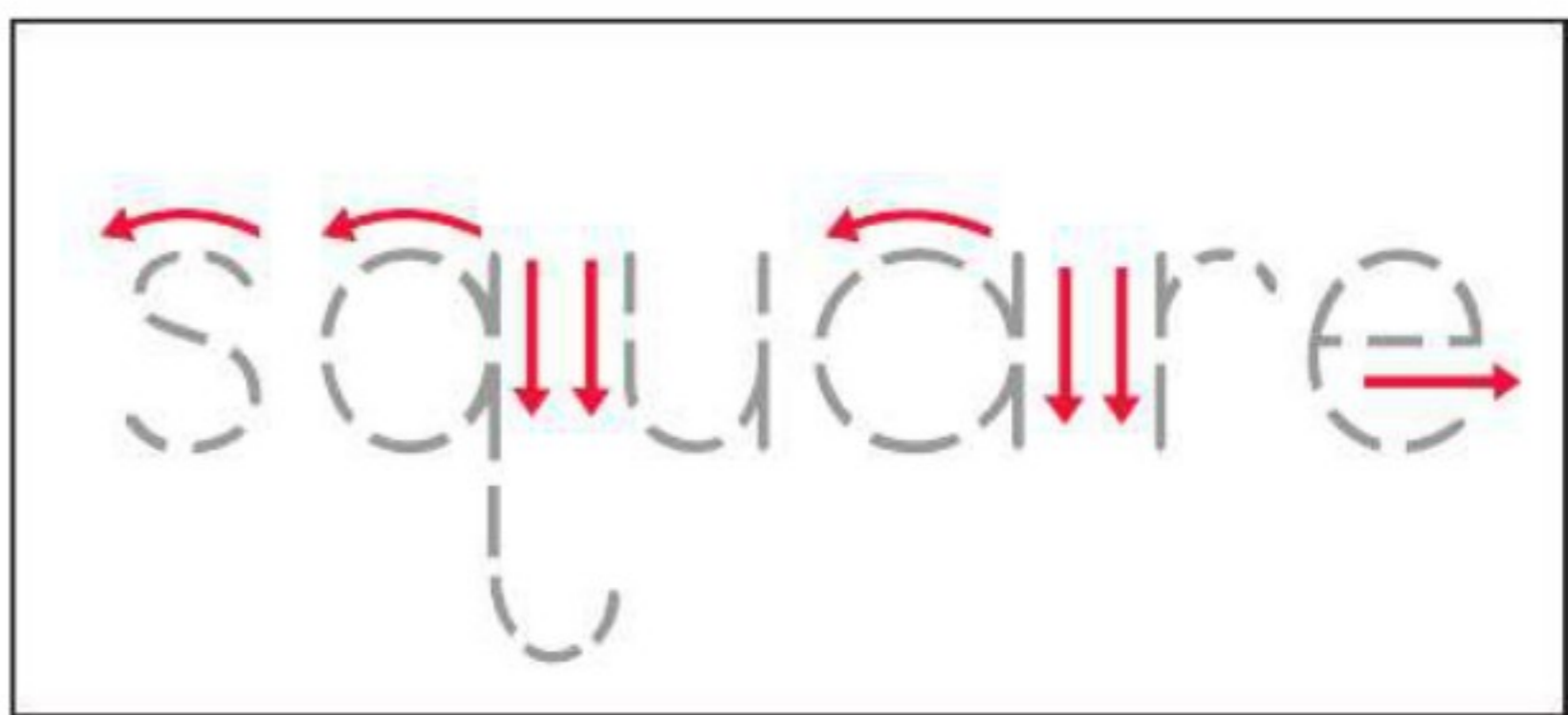

Blank box for independent writing practice.



# Color Squares

**Directions:** Color  the ten things in the picture which are made with s.

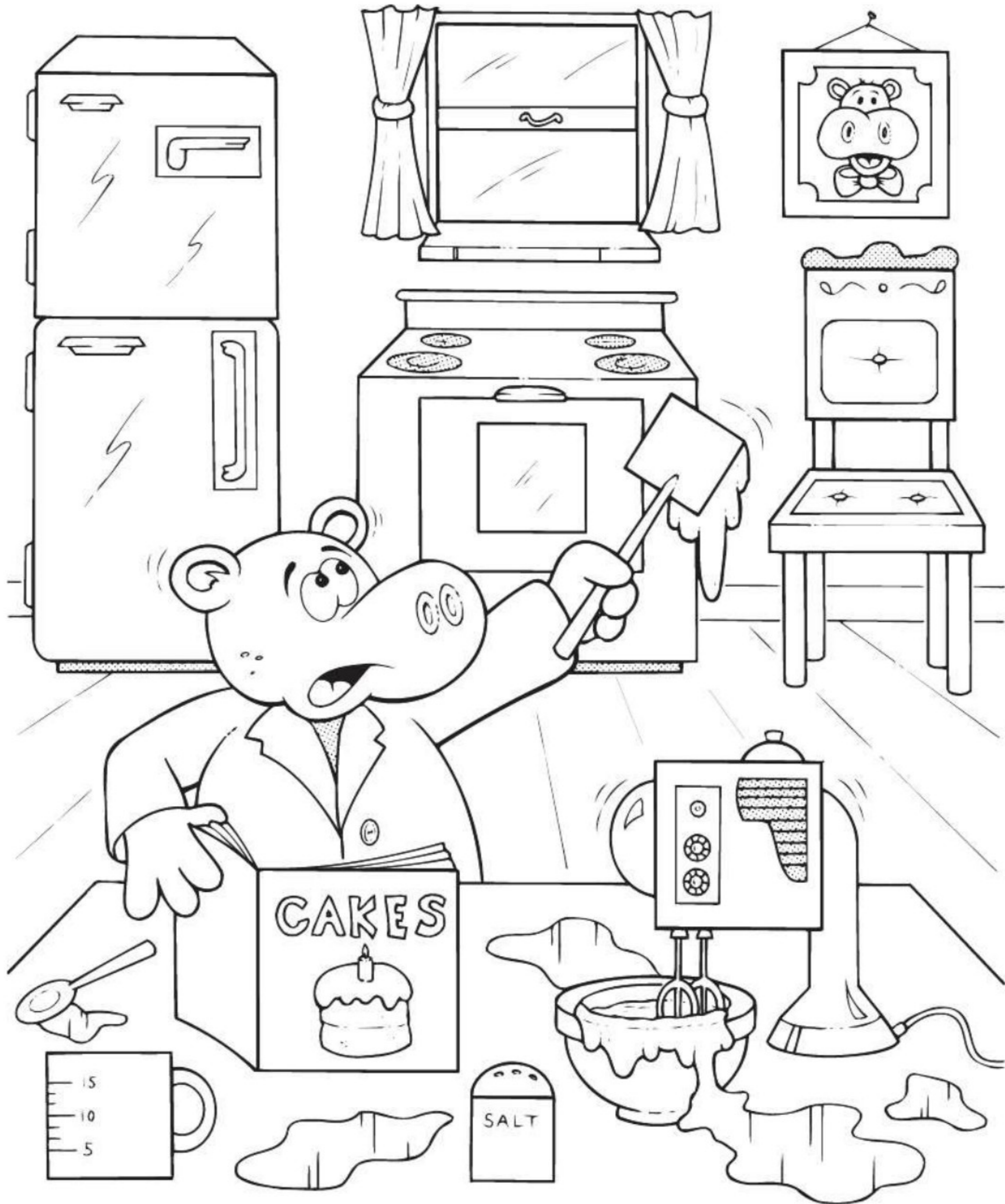



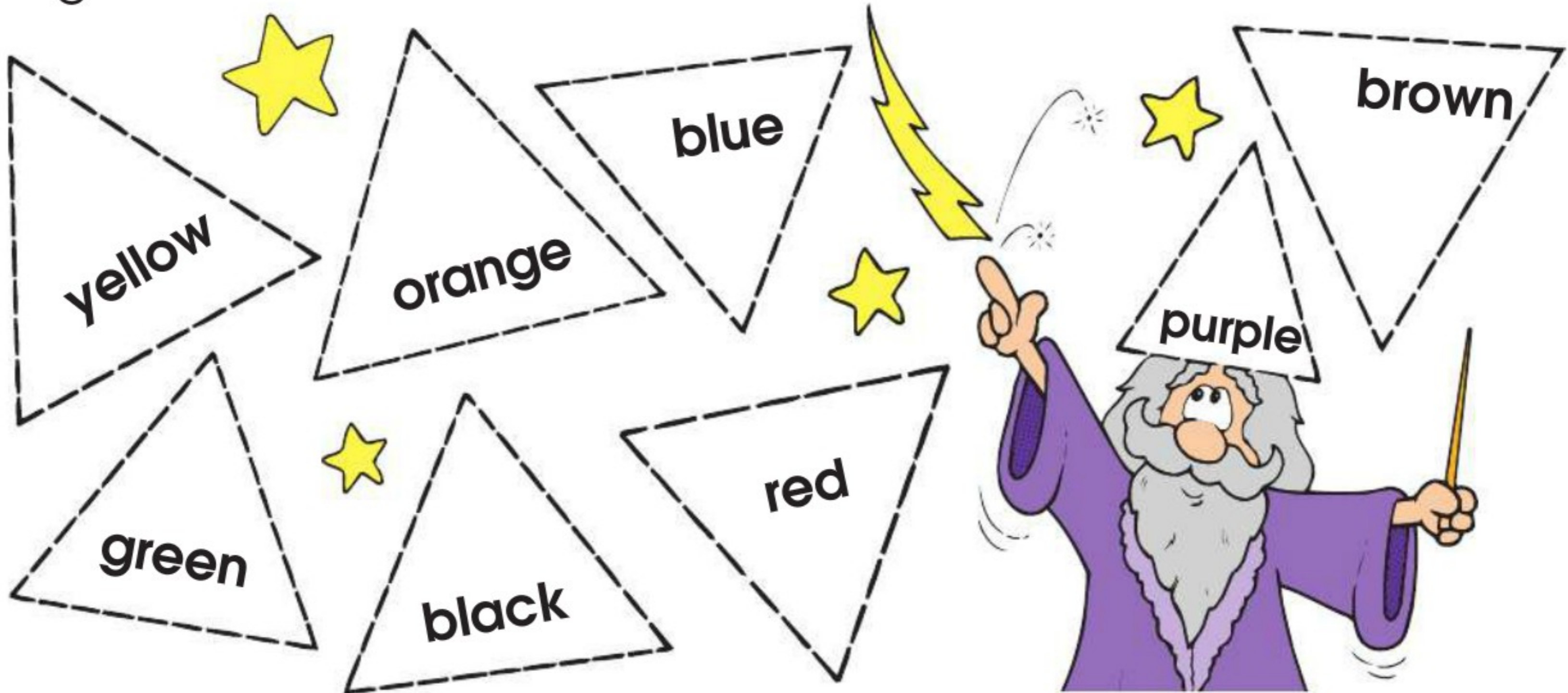

# Trace and Write Triangles

**Directions:** This is a triangle: . **Trace**  and **color**  each triangle the correct color.



**Directions:** **Trace**  the word "triangle" in the second box below. Then, in the third box, **write**  "triangle" on your own.

triangle

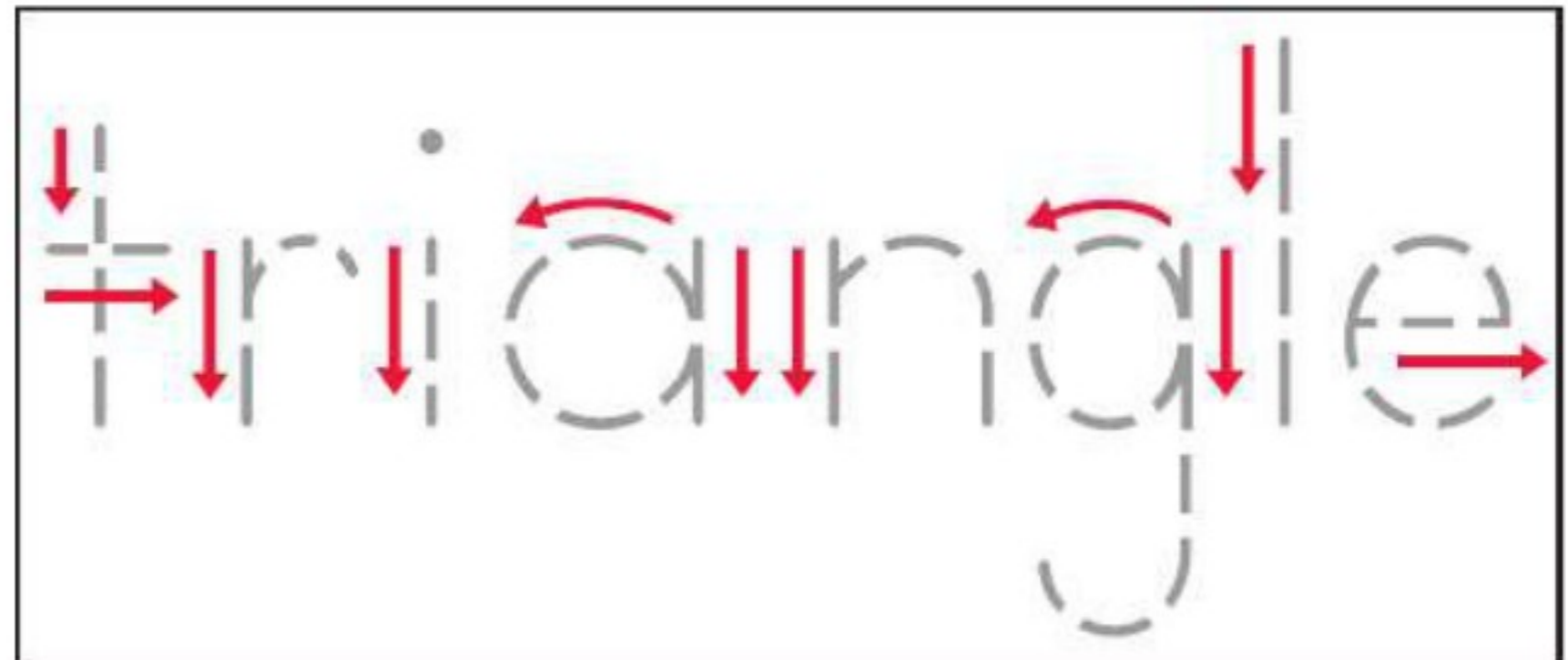



# Color and Circle Triangles

**Directions:** Color  each  tree to find the path home.

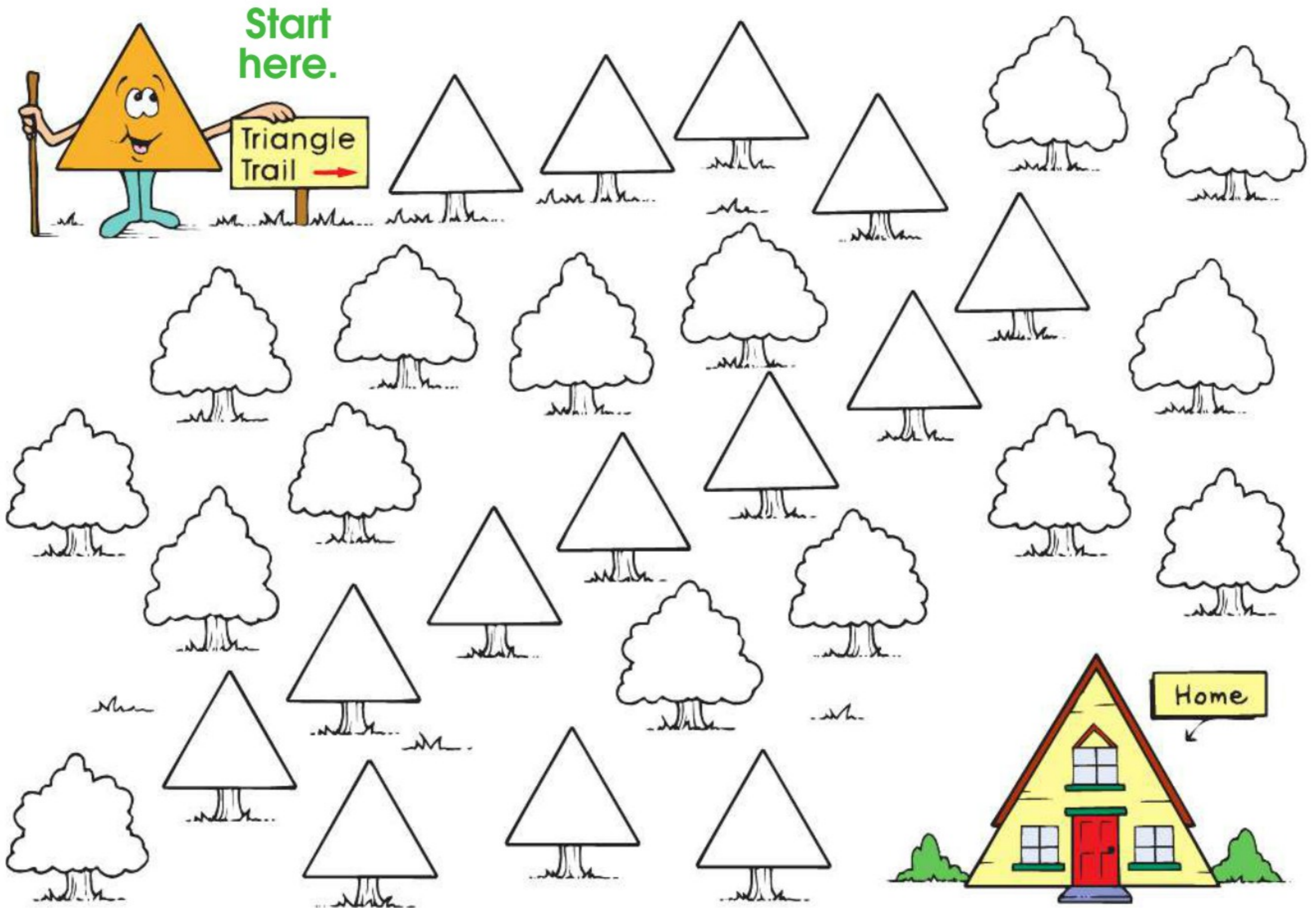

**Directions:** Circle  each picture made with a .

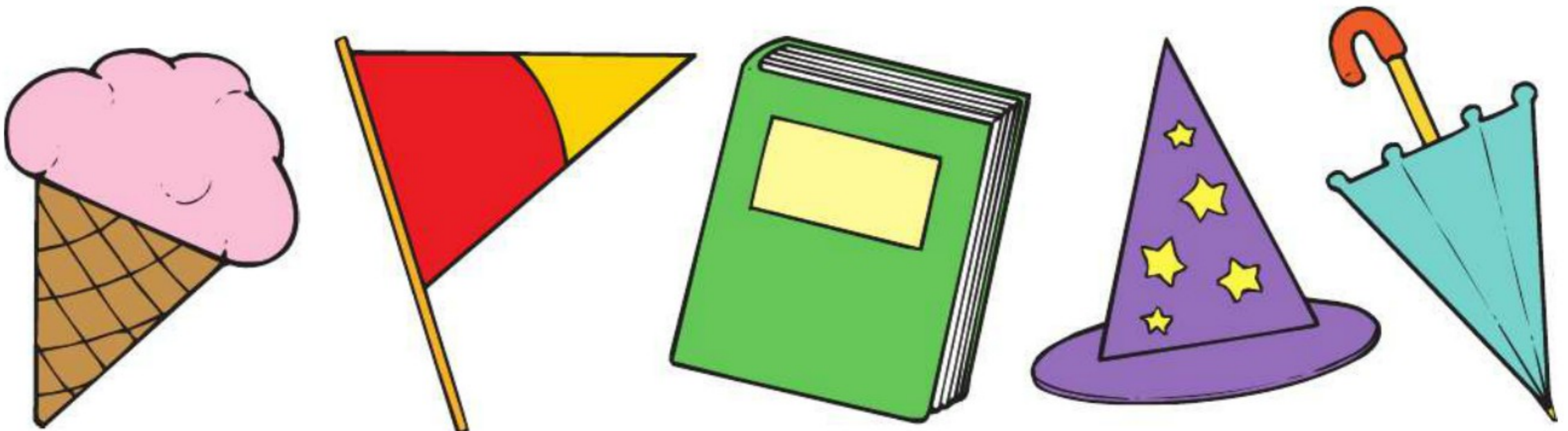



# Trace and Write Rectangles

**Directions:** This is a rectangle: . **Trace**  and **color**  each rectangle the correct color.

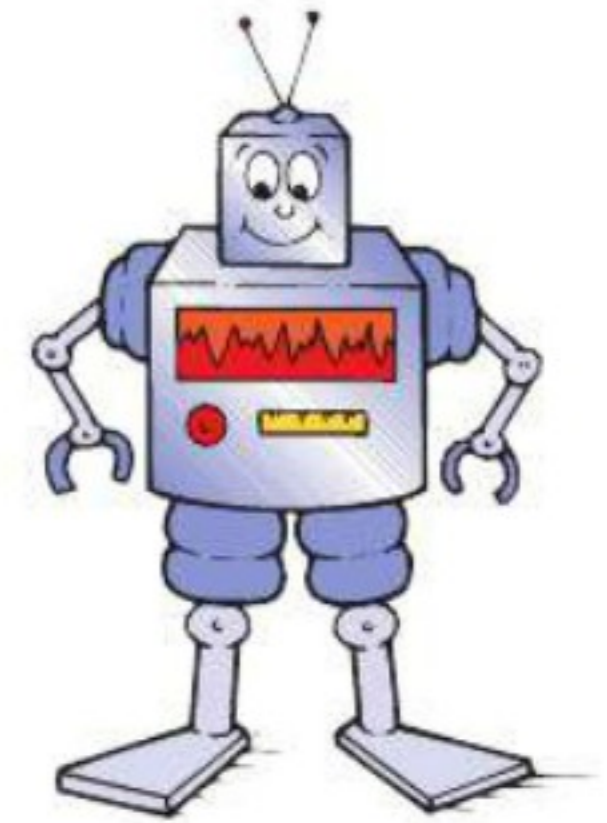
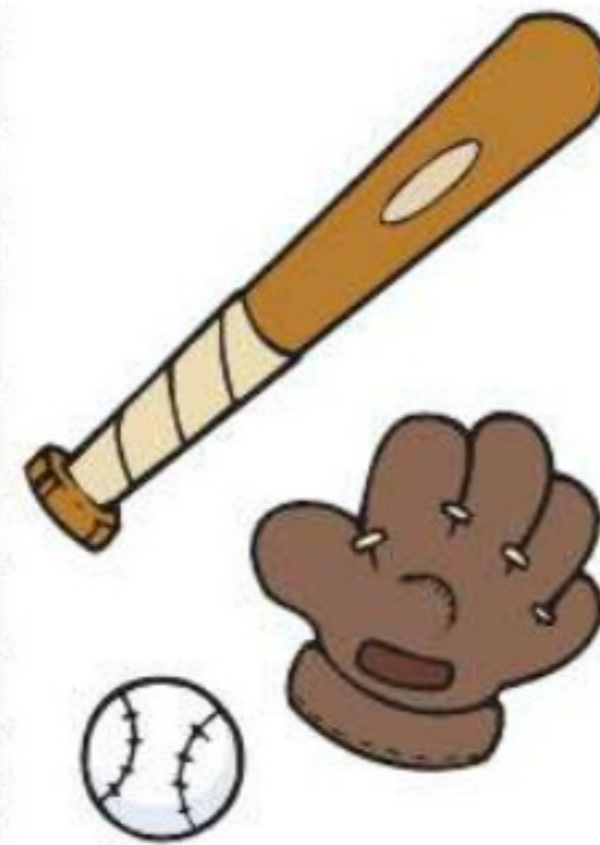
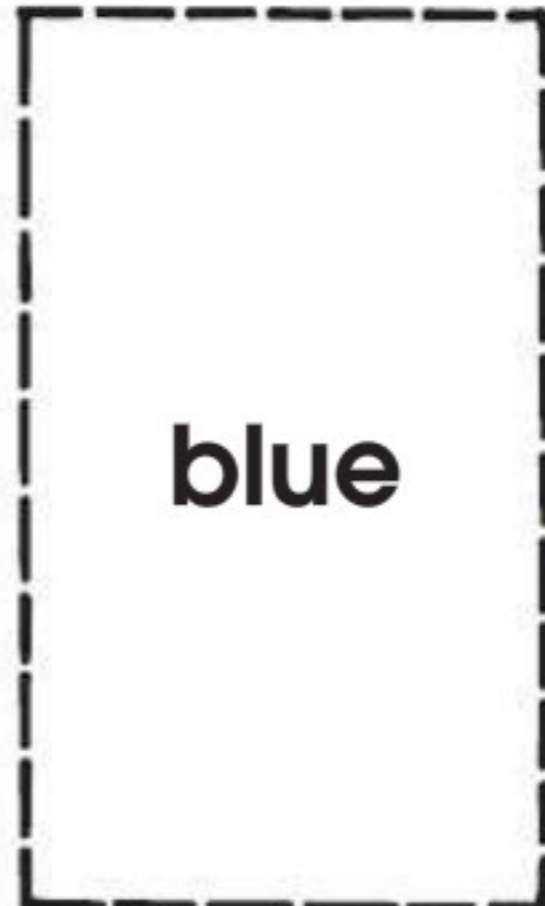
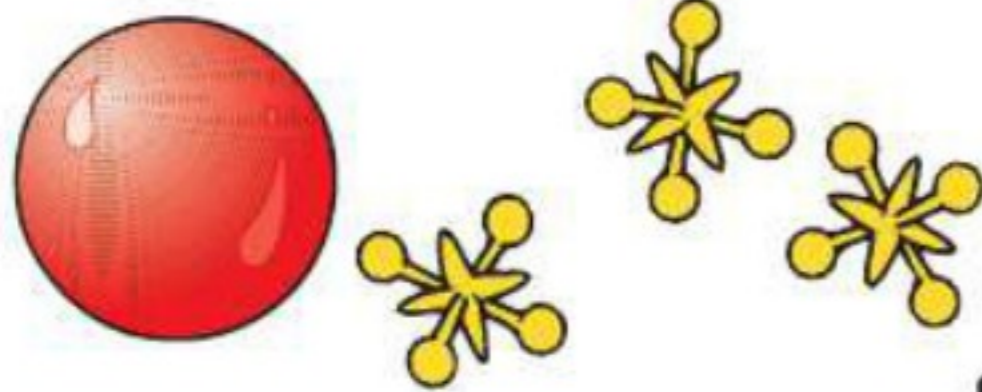

**Directions:** **Trace**  the word "rectangle" in the second box below. Then, in the third box, **write**  "rectangle" on your own.

rectangle

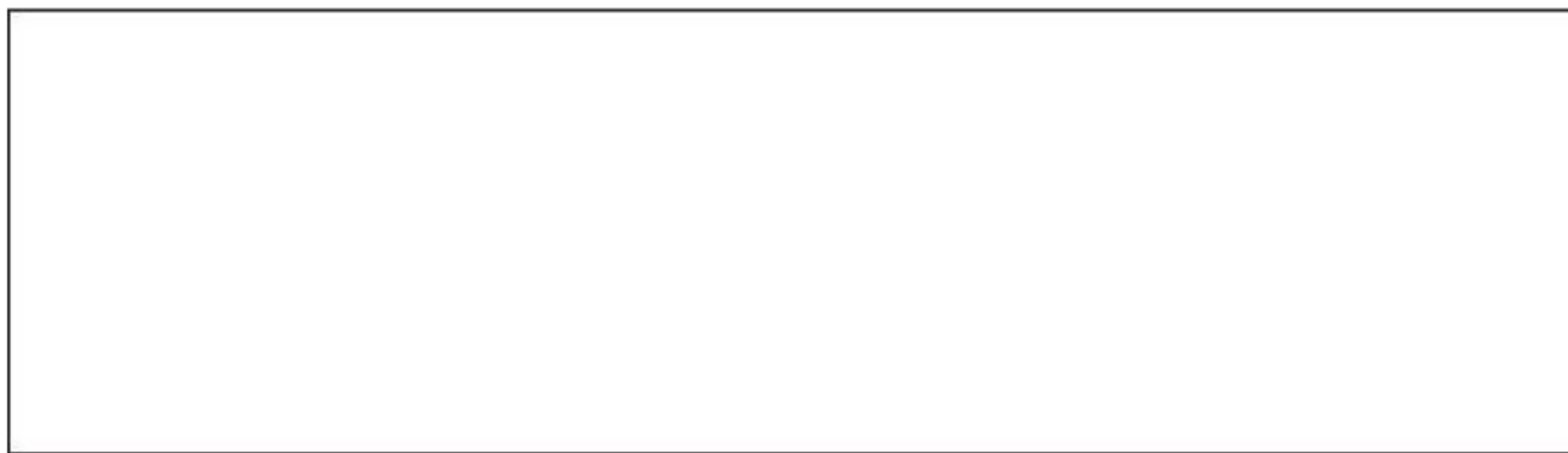
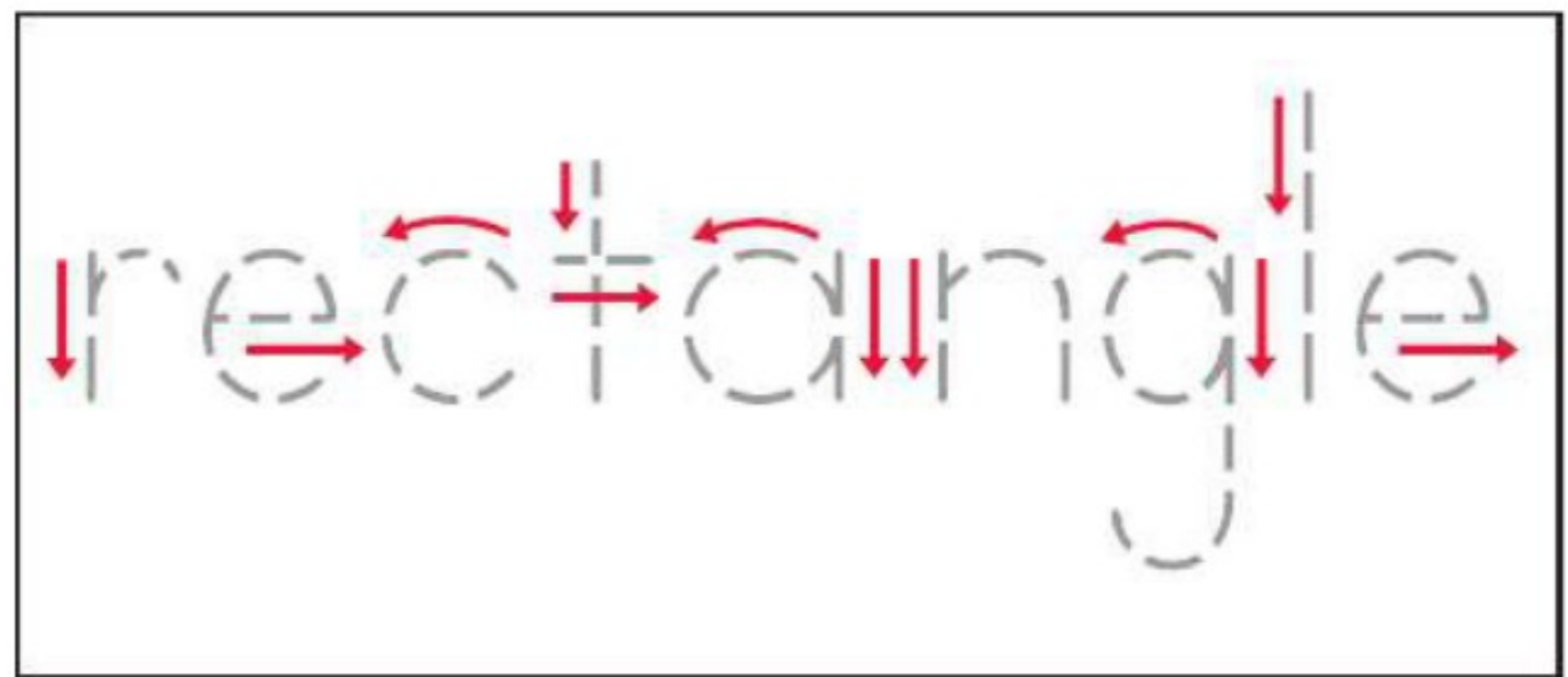



# Color and Cut Out Rectangles

**Directions:** Color , cut , and glue  each  to complete the picture.

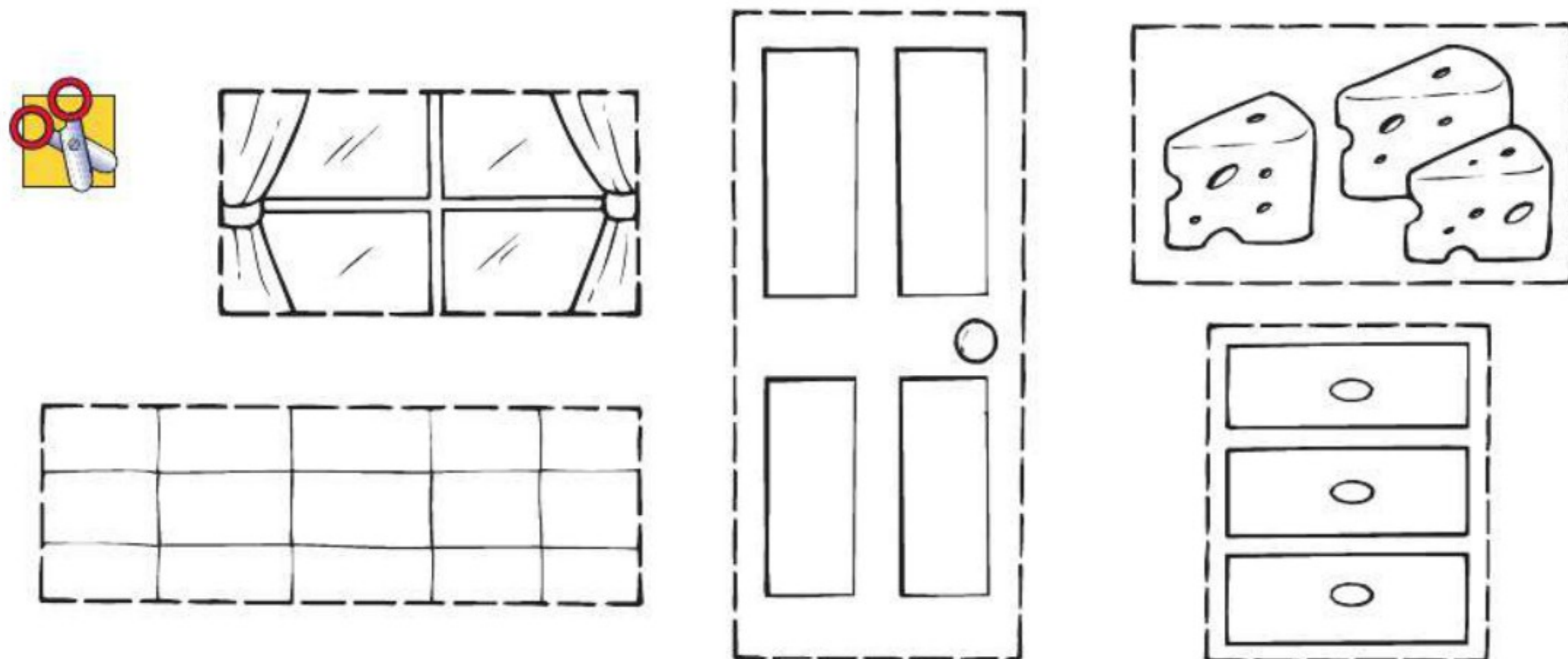
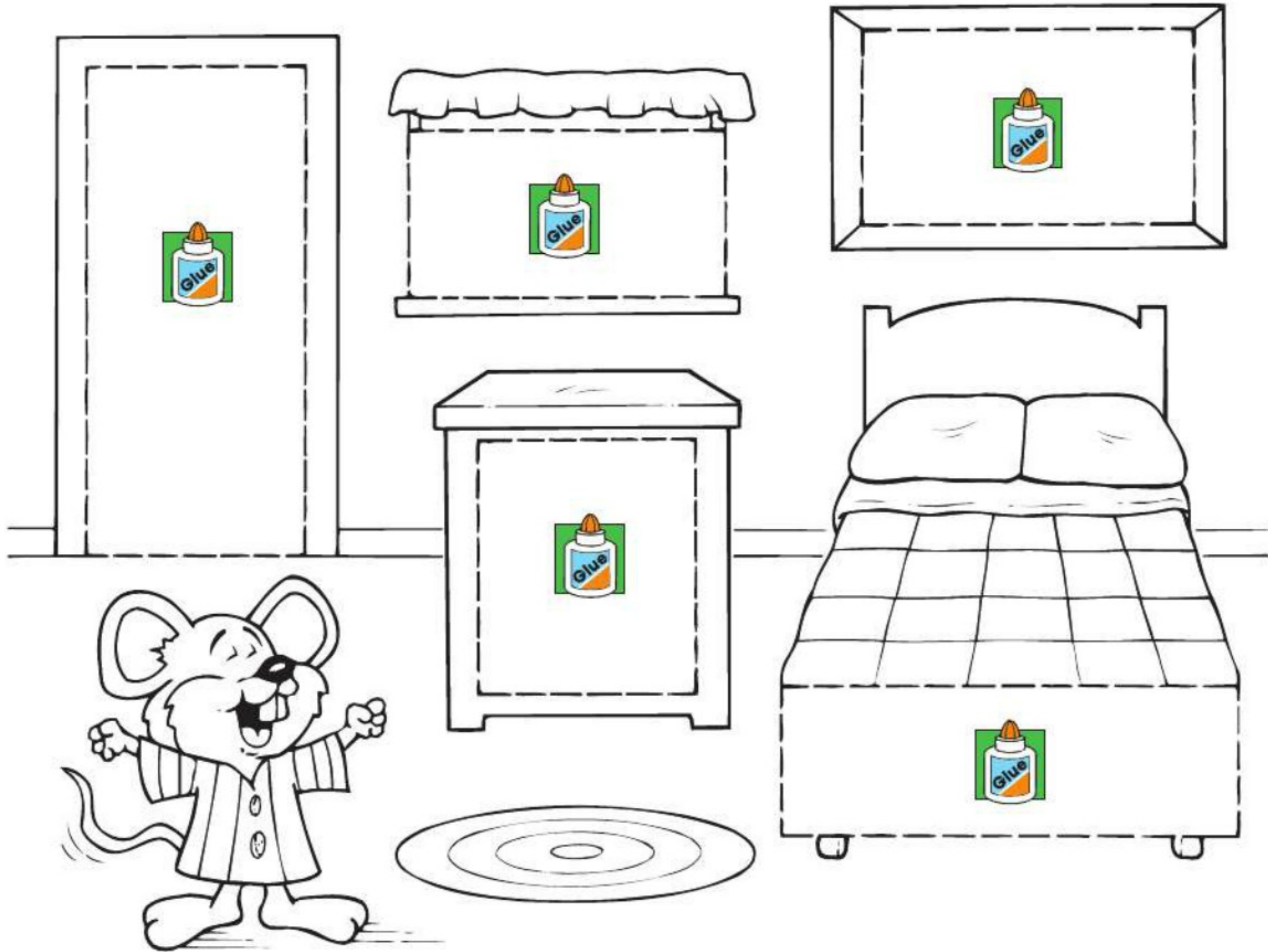











# Shape Review

**Directions:** Color  each square **blue**. Color  each circle **green**. Color  each triangle **brown**. Then, finish the picture with your favorite colors!





# Big

**Directions:** Some things are **big**. Some things are **small**. Which one is big? **Color**  the one that is big in each row.

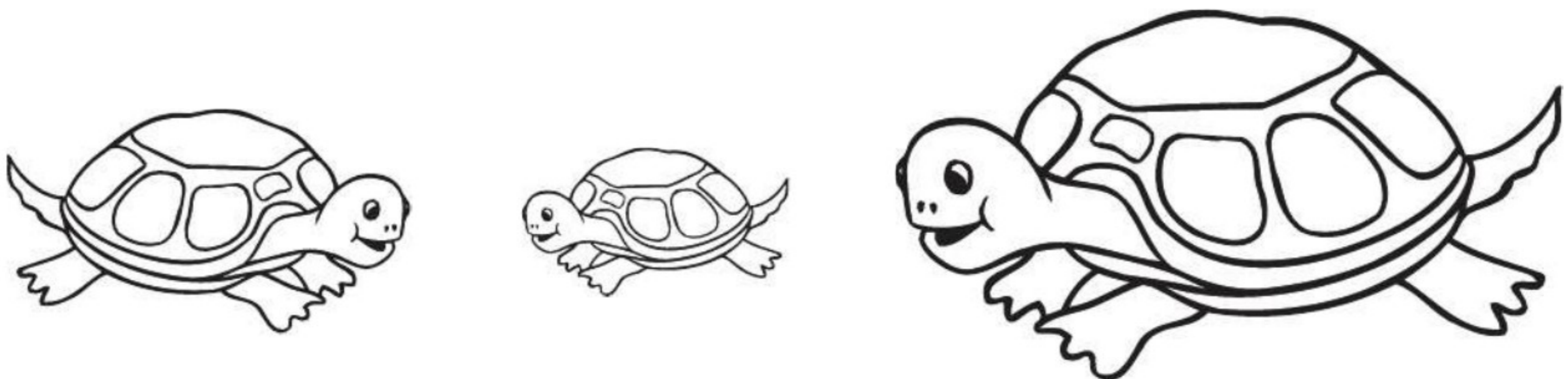
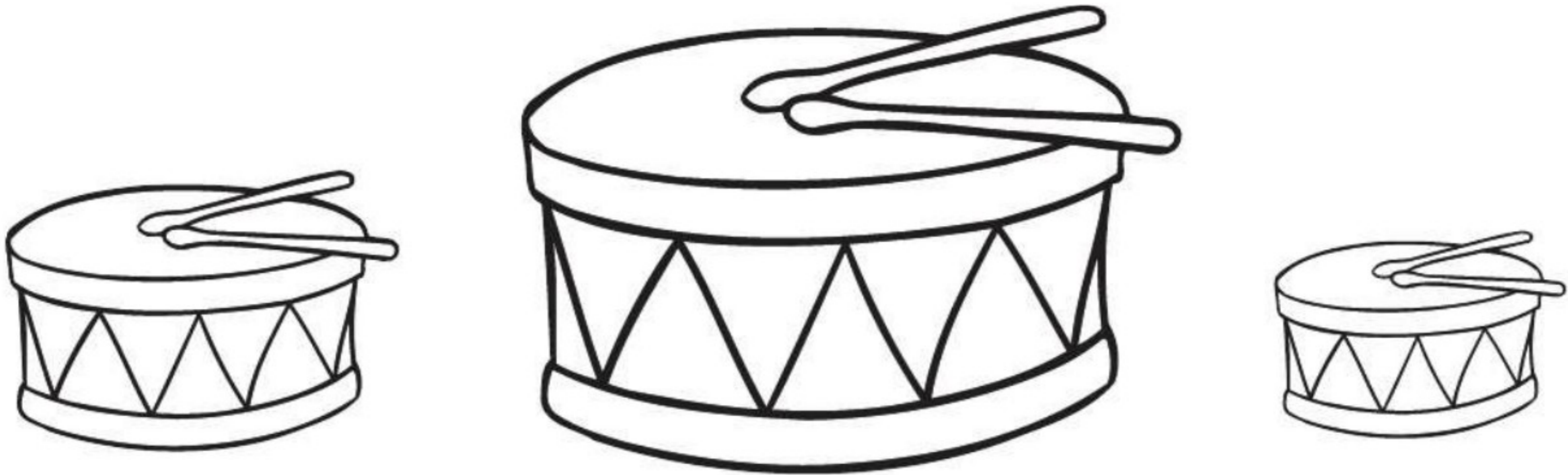

Name \_\_\_\_\_

SIZES



## Small

**Directions:** Which one is small? **Color**  the one that is small in each row.

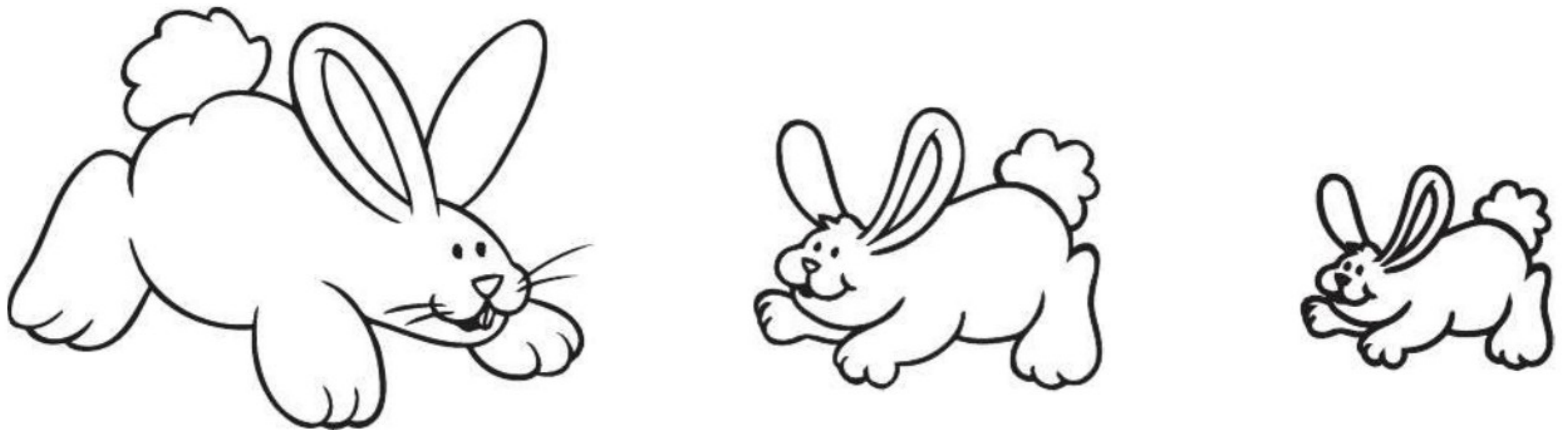
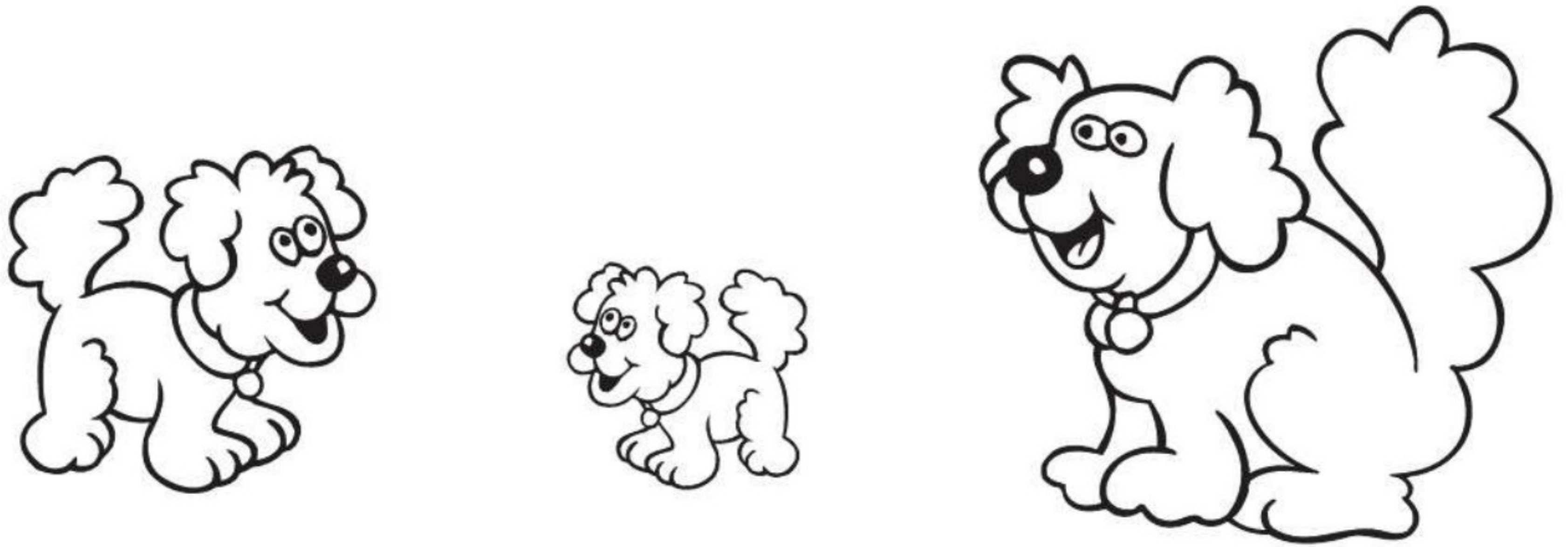
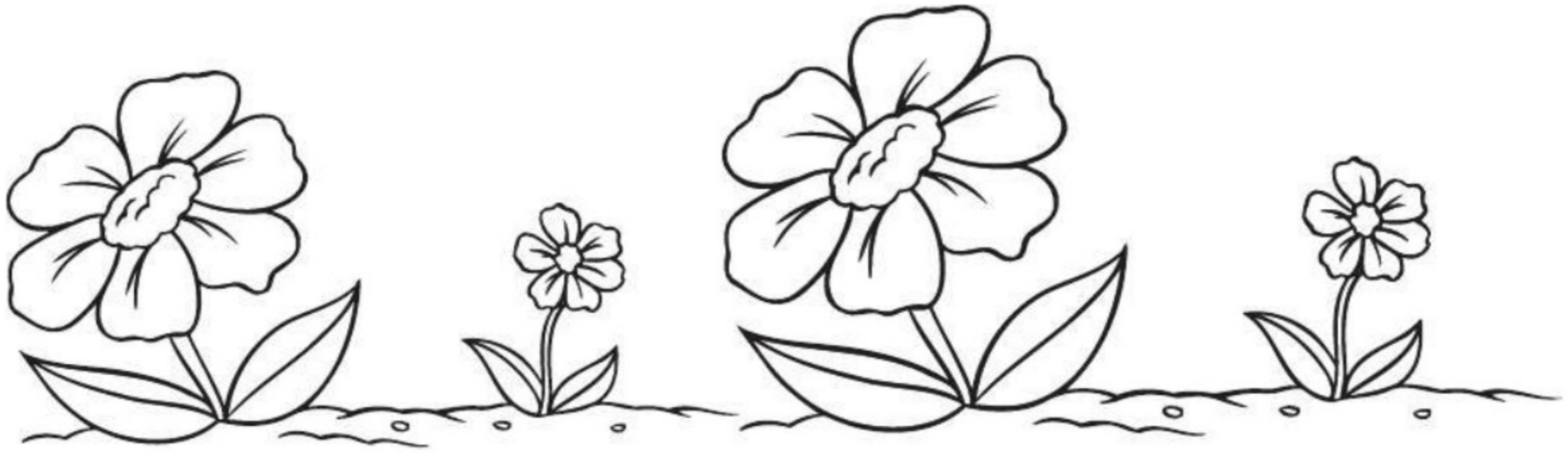



# Long

**Directions:** Some things are **long**. Some things are **short**. Color  the things that are long in each row.

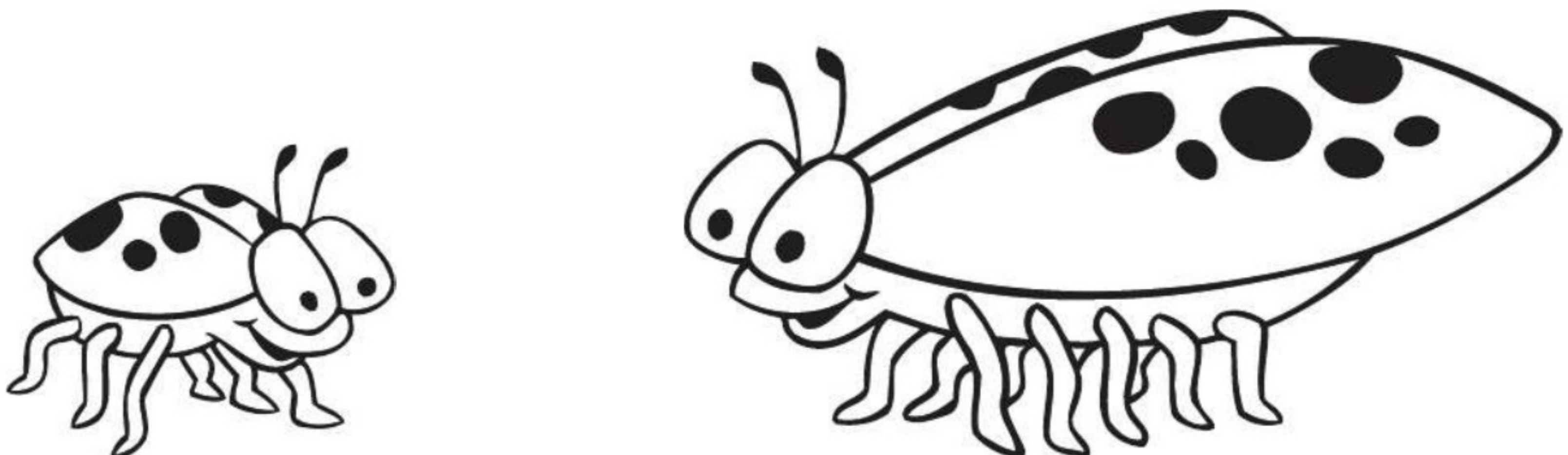
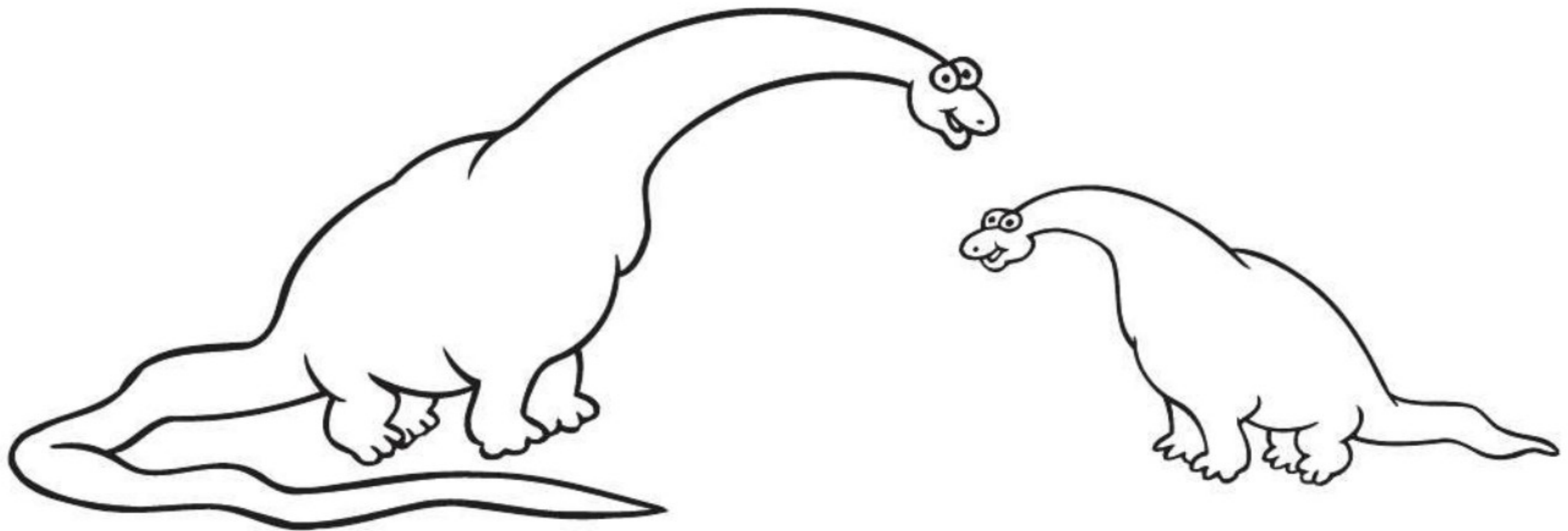
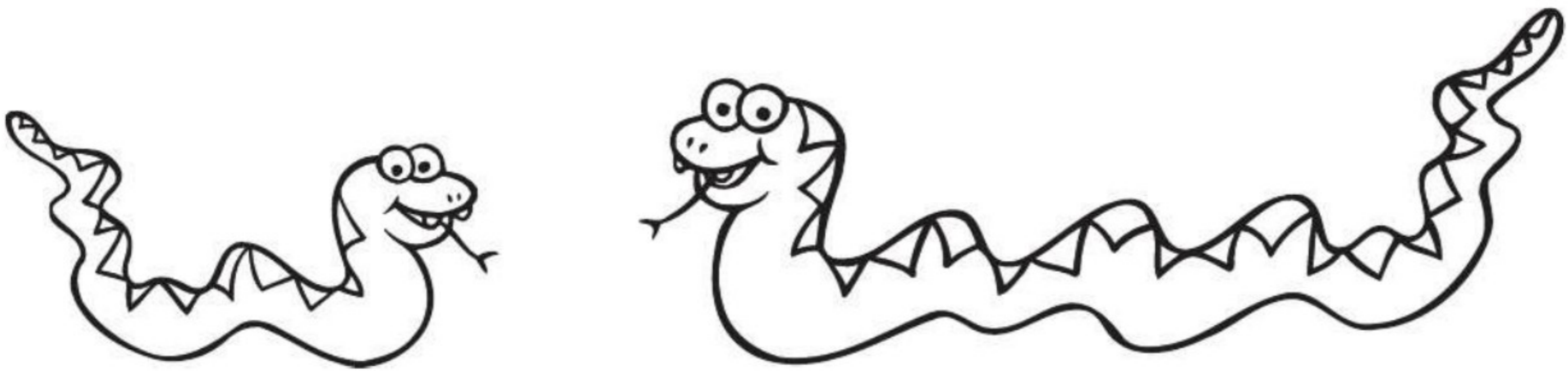

Name \_\_\_\_\_

SIZES



# Short

**Directions:** Which one is short? **Color**  the one that is short in each row.

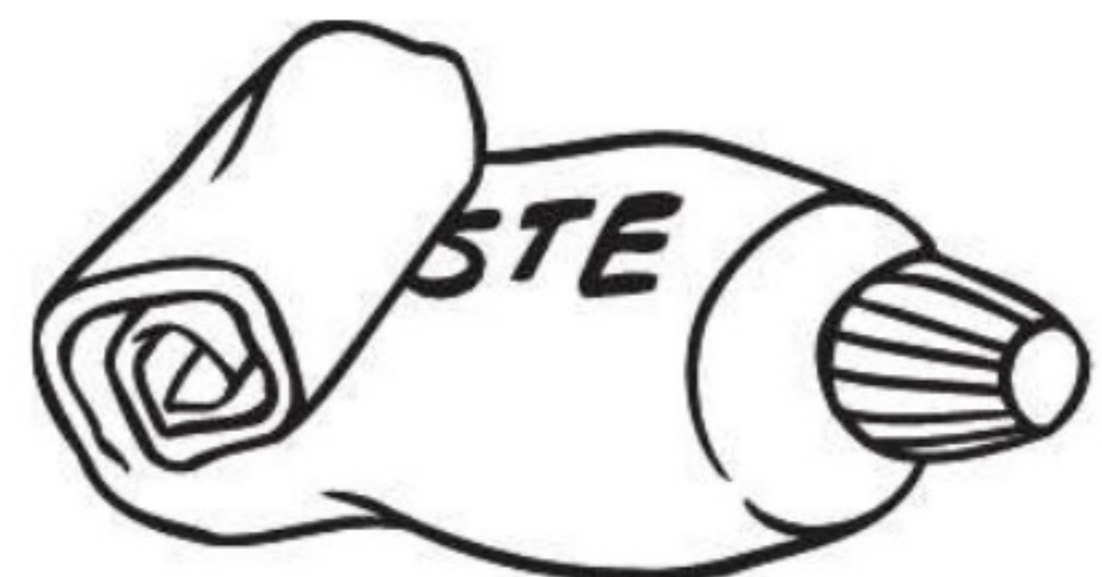
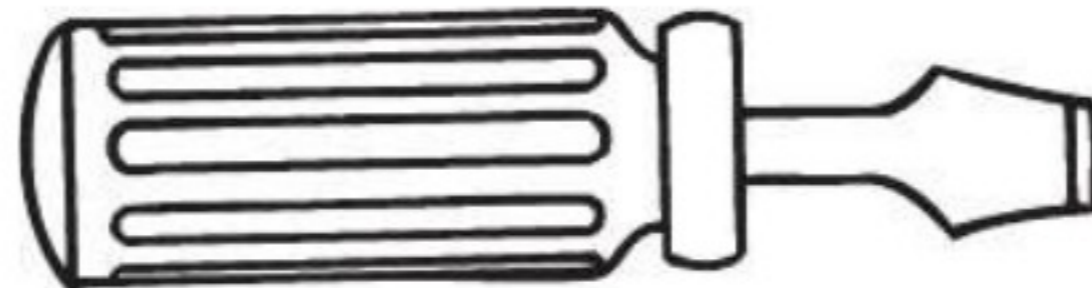
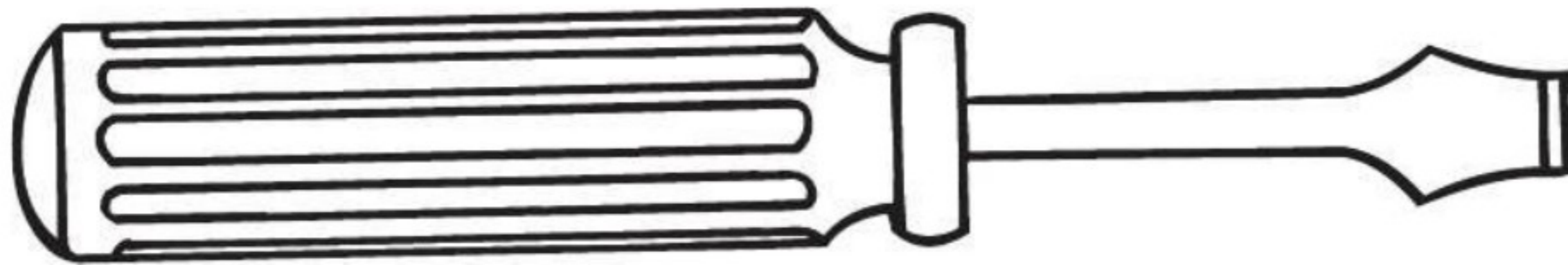
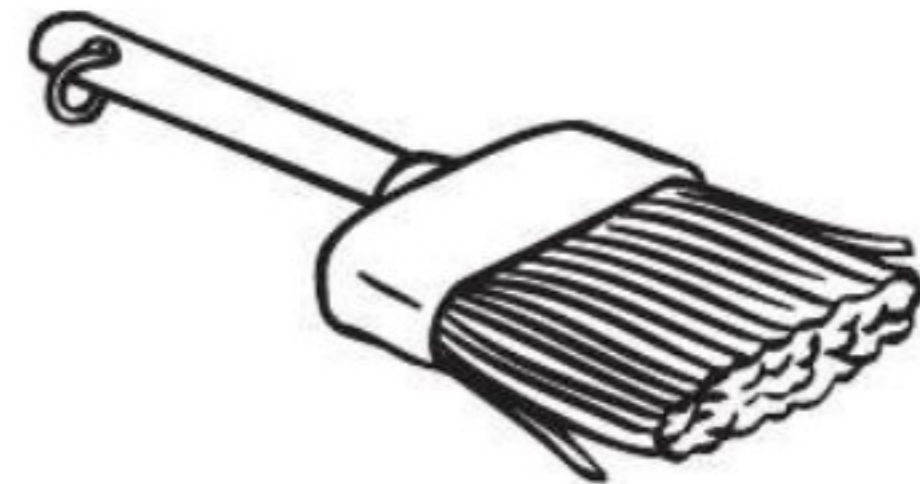
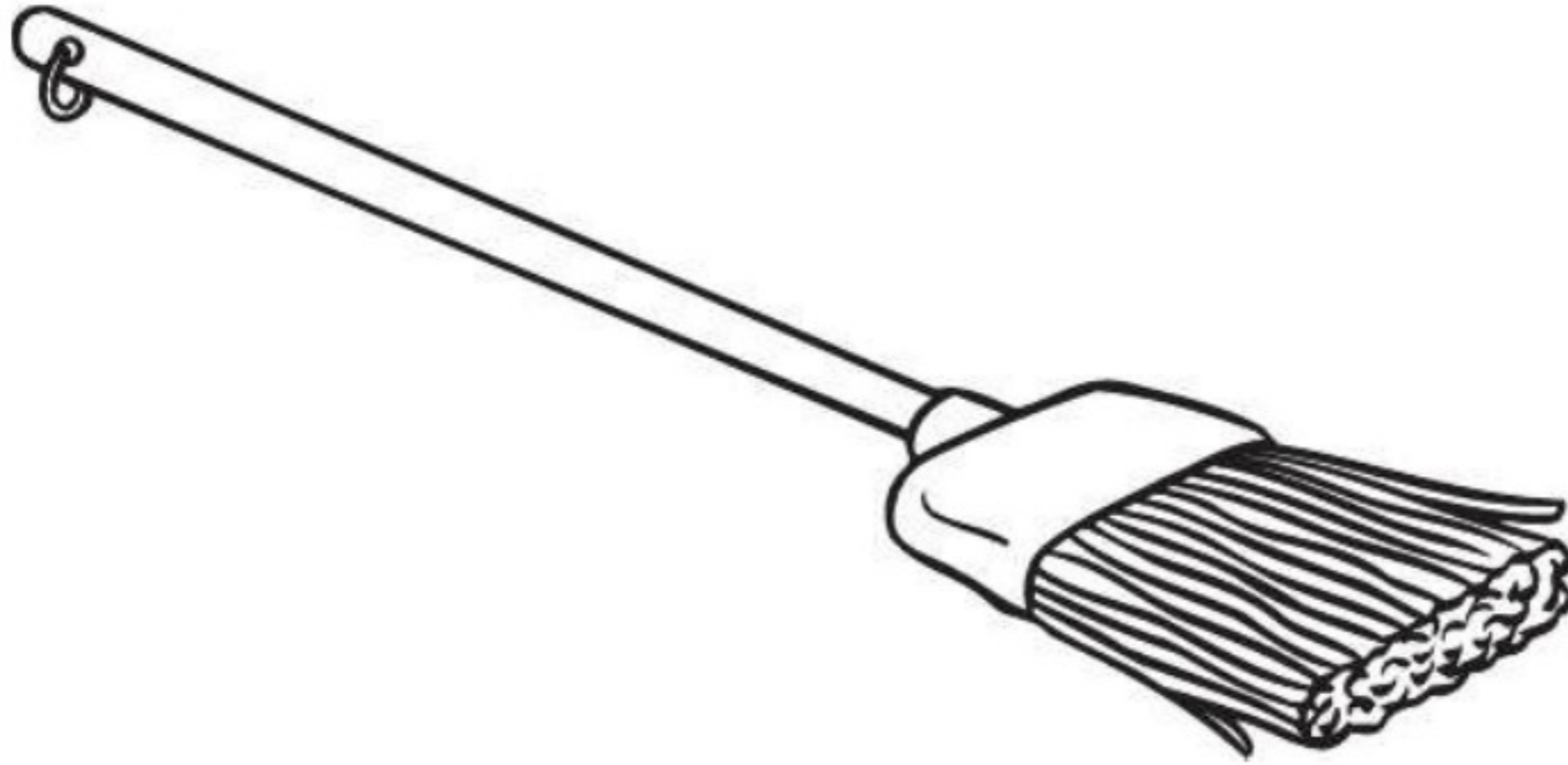



# Tall

**Directions:** Some things are **tall**. Some things are **short**. Look at the pictures in each box. **Color**  the people who are tall.

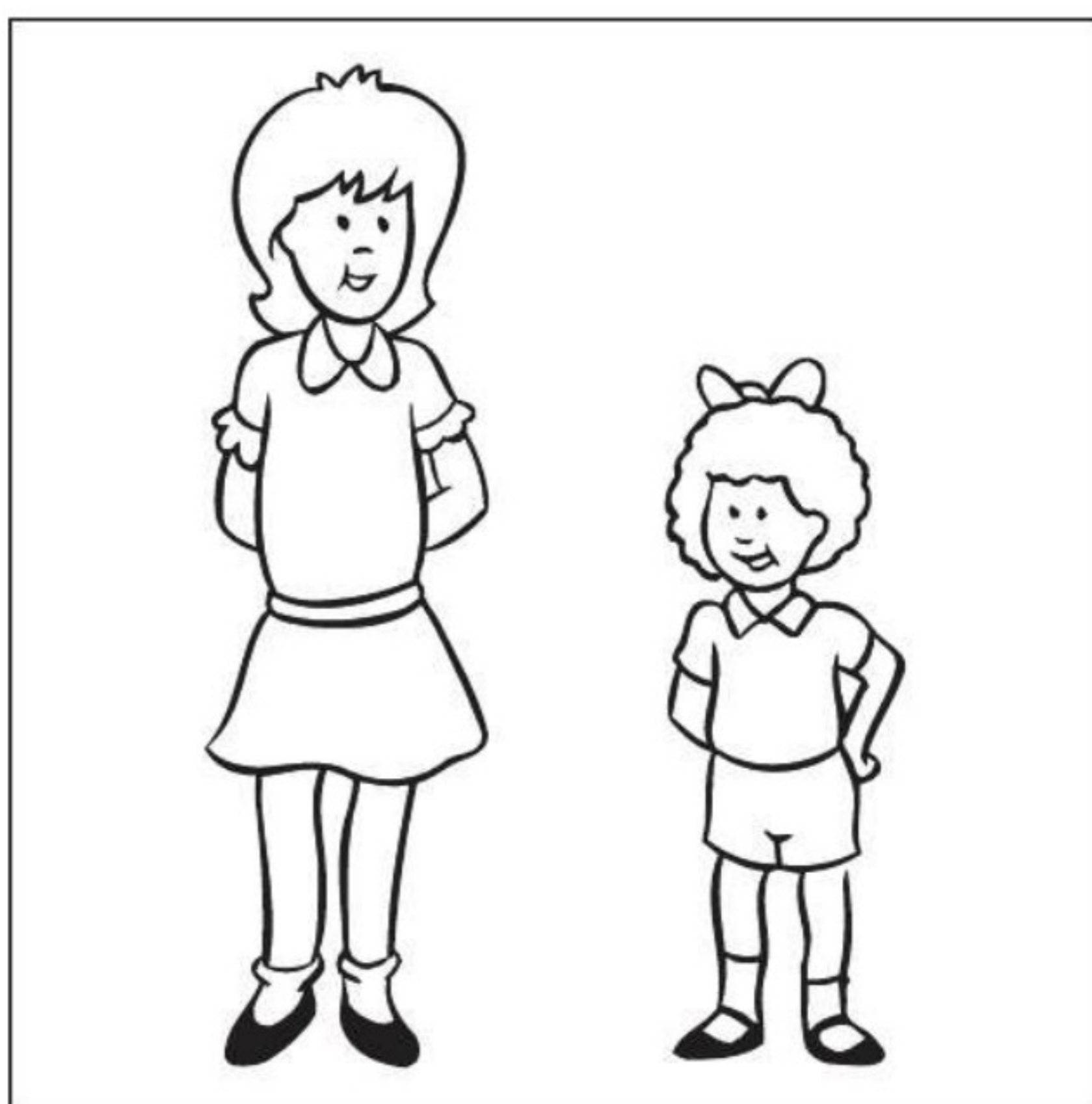
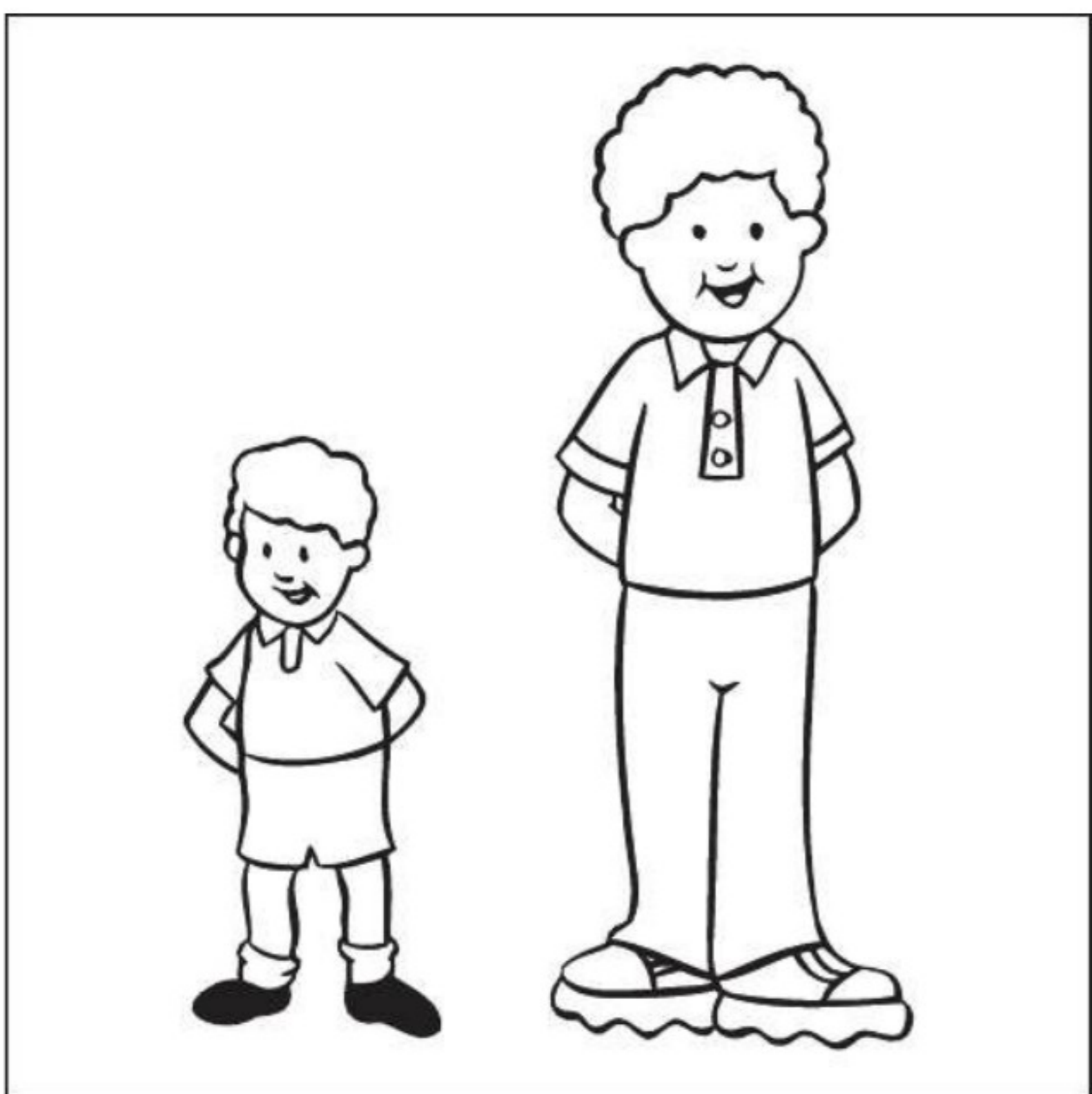
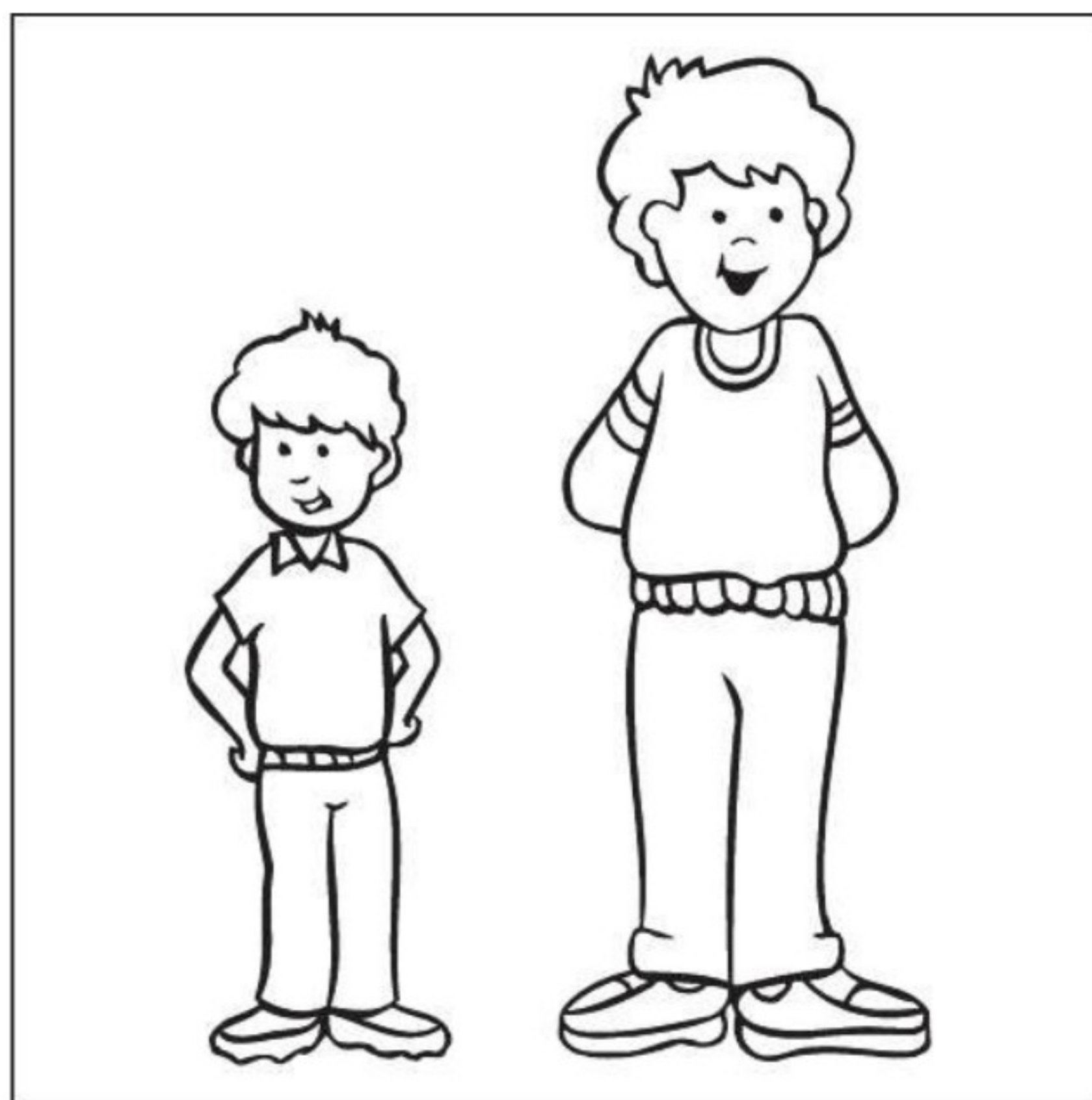

Name \_\_\_\_\_

SIZES



# Short

**Directions:** Look at the pictures in each box. **Color**  the objects that are short in each box.

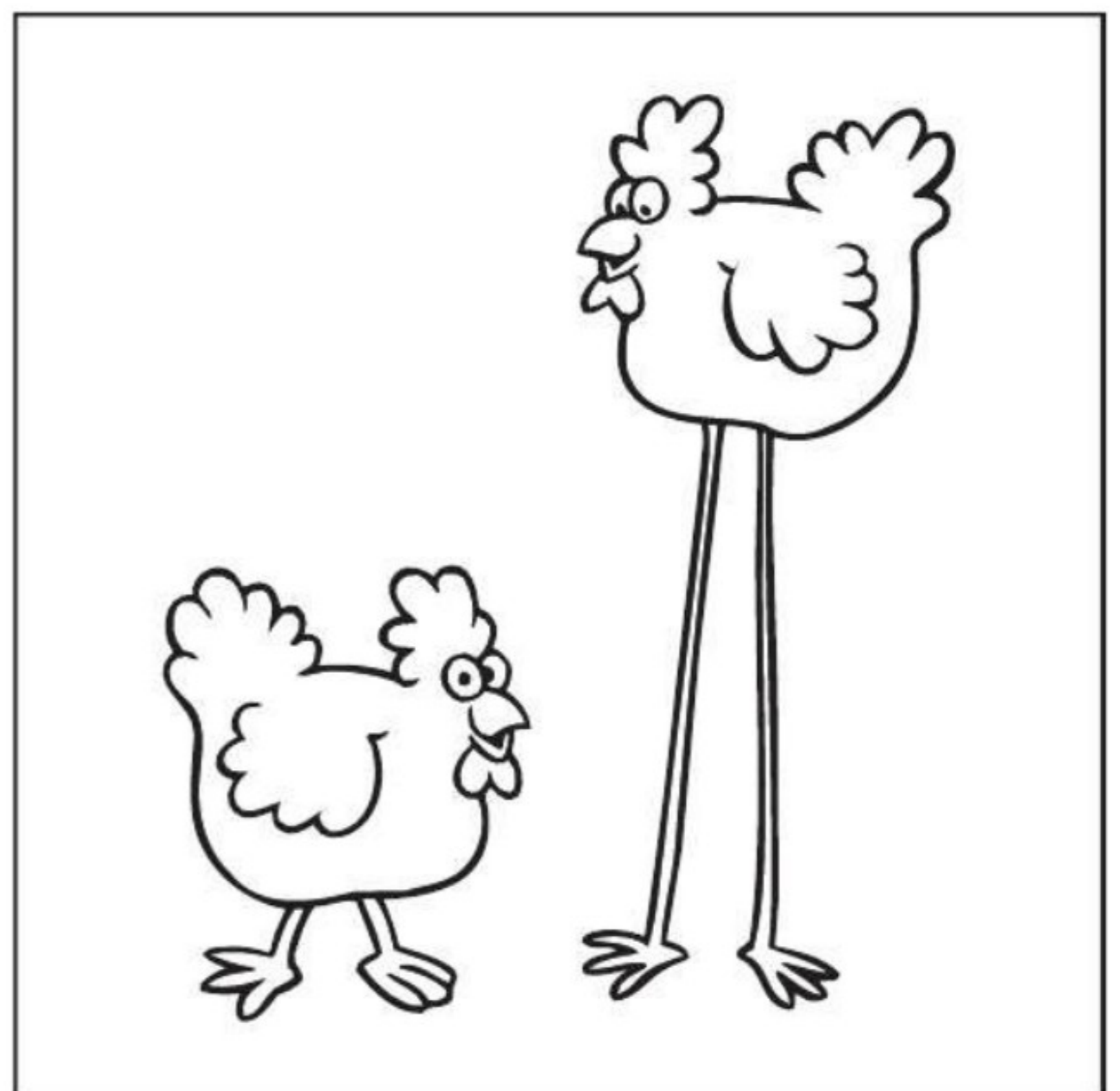
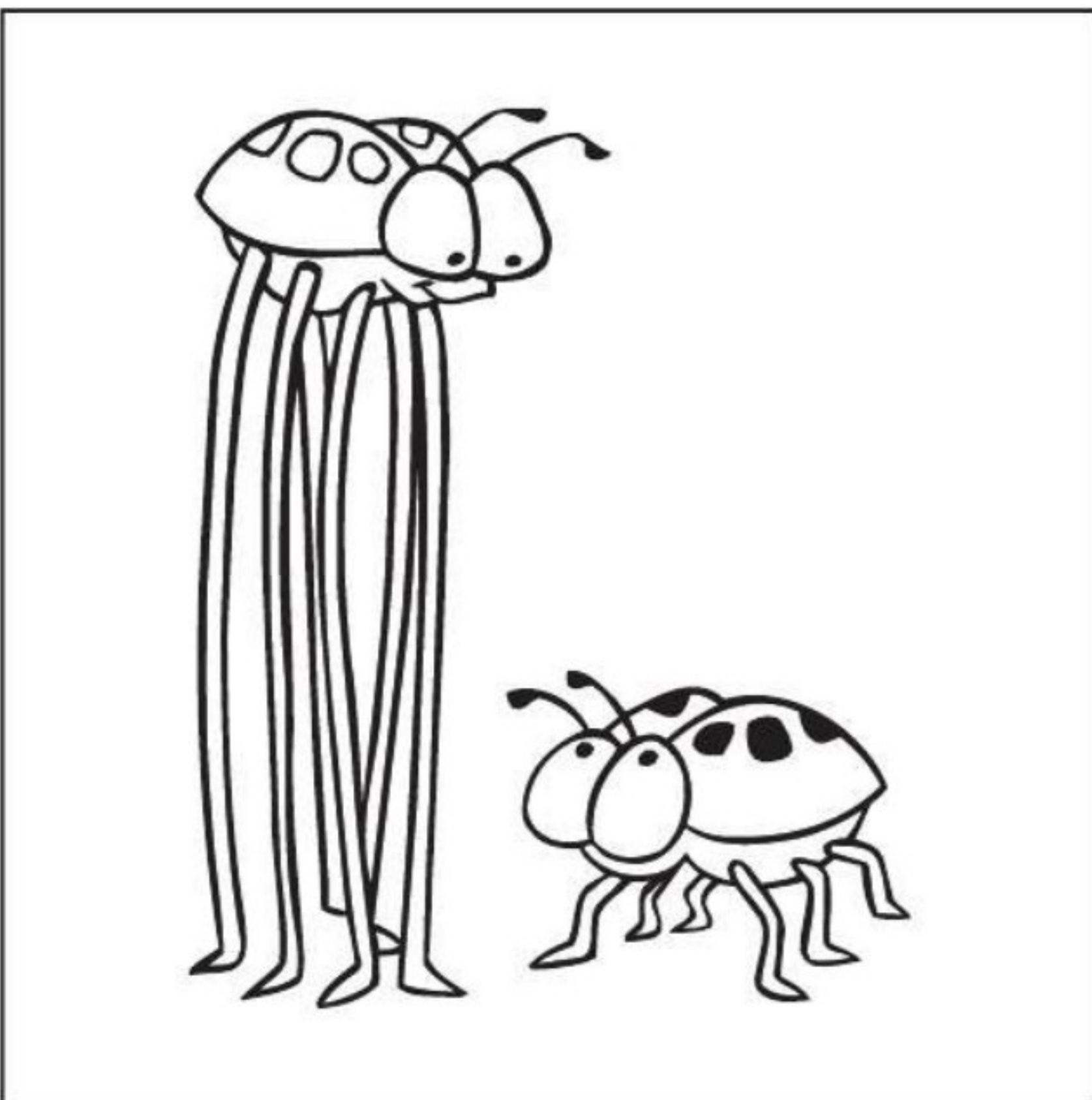
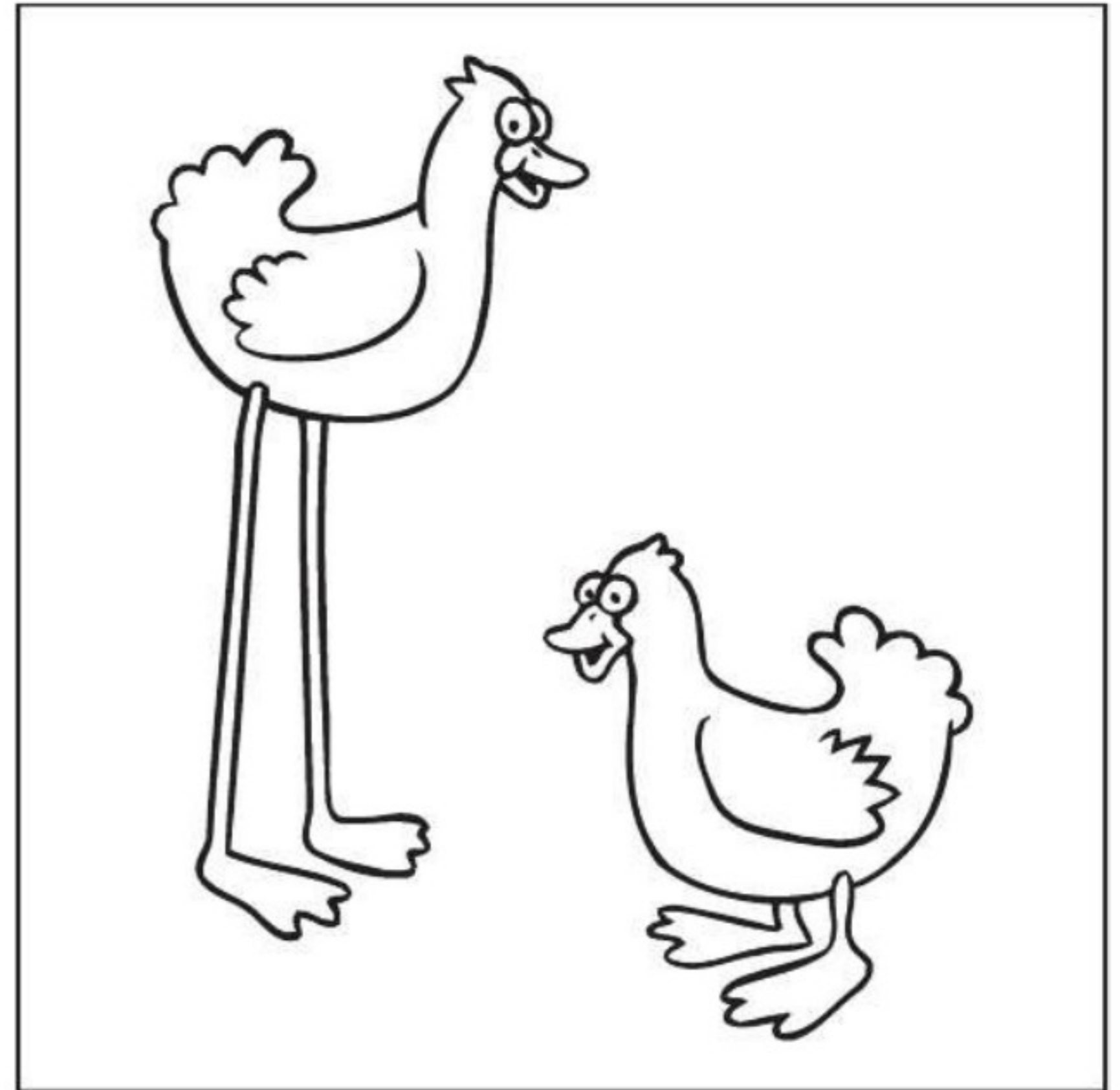
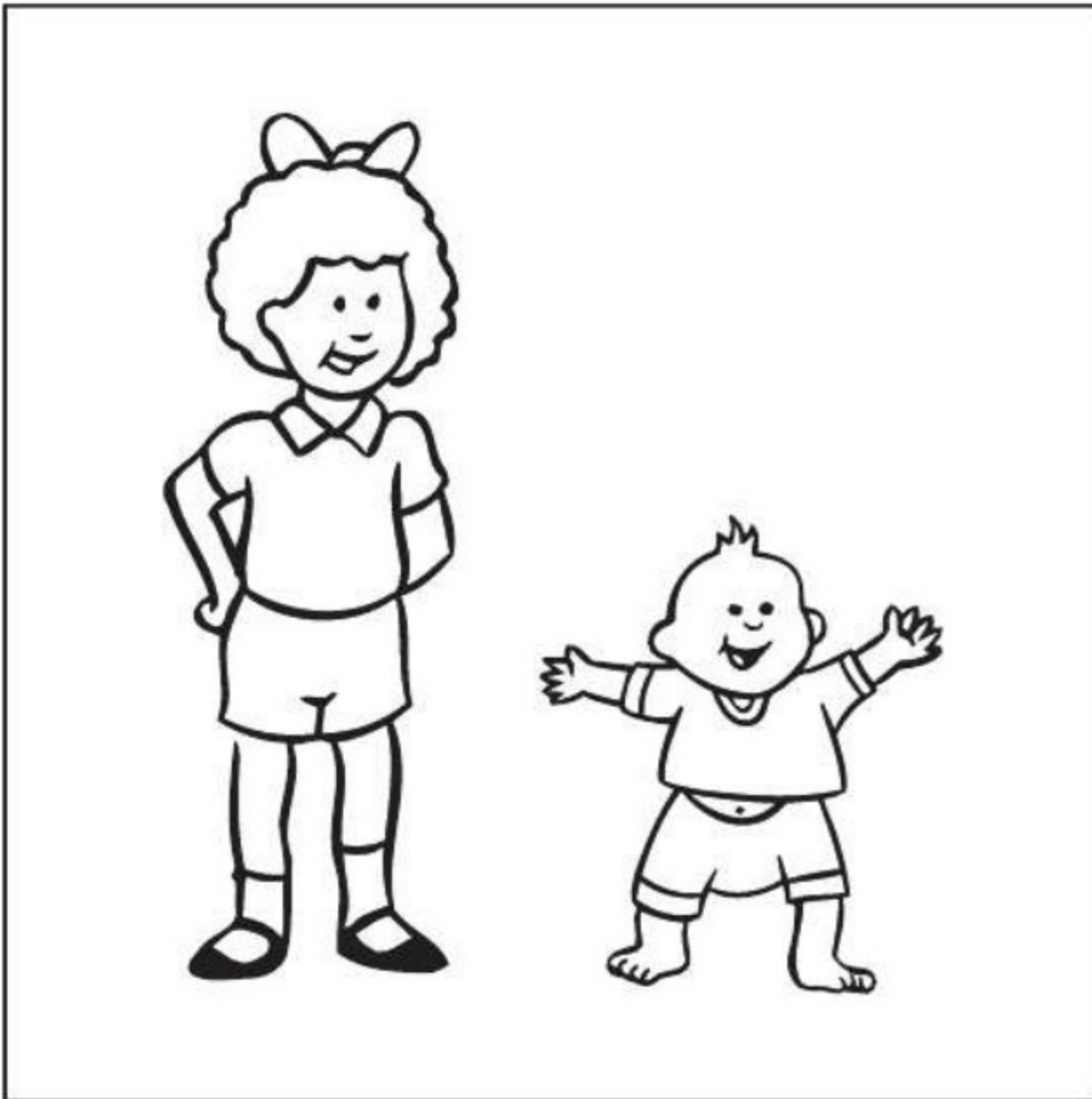



# Full and Empty

**Directions:** Circle  the full container. Draw an X  on the empty container.

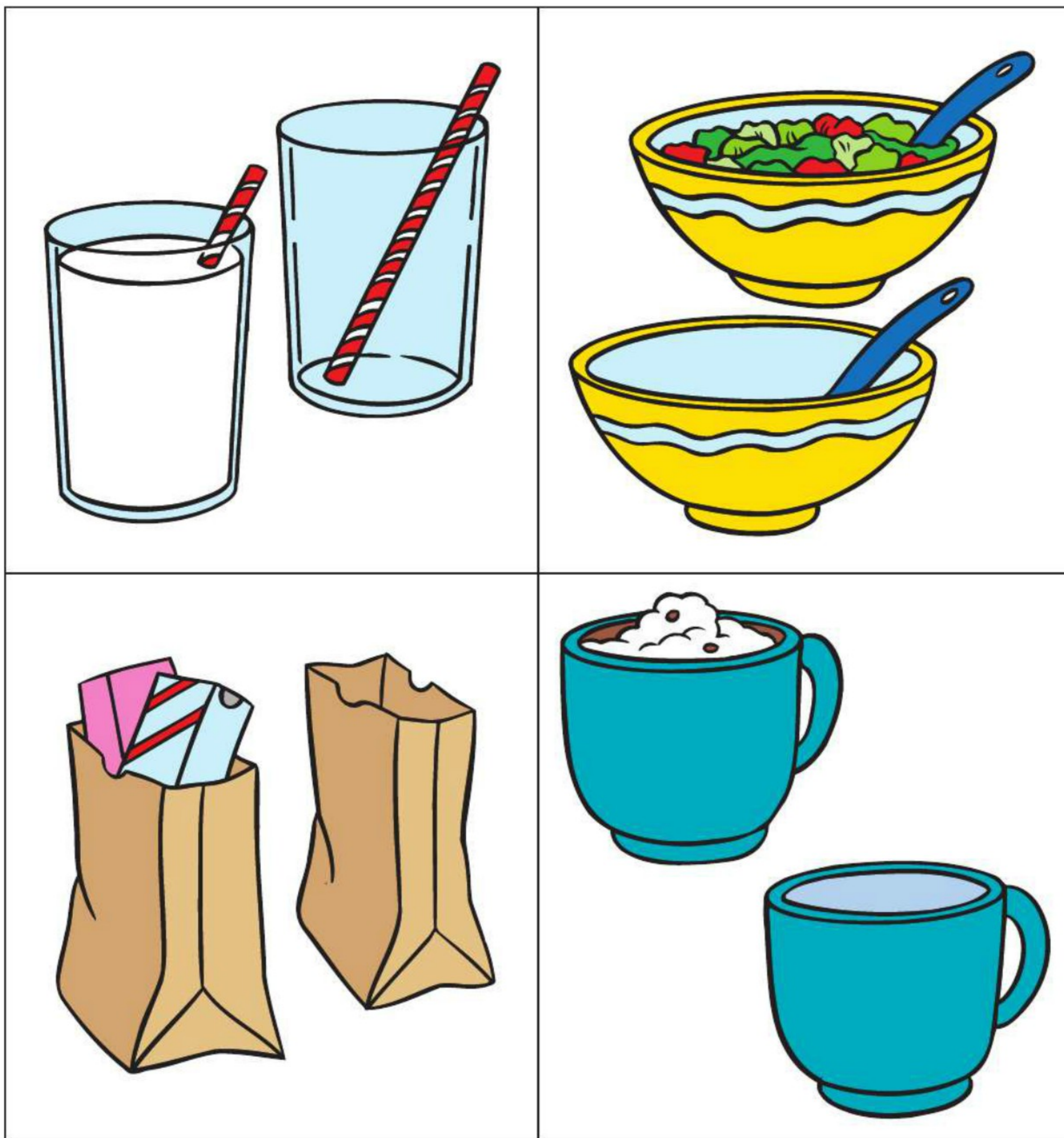







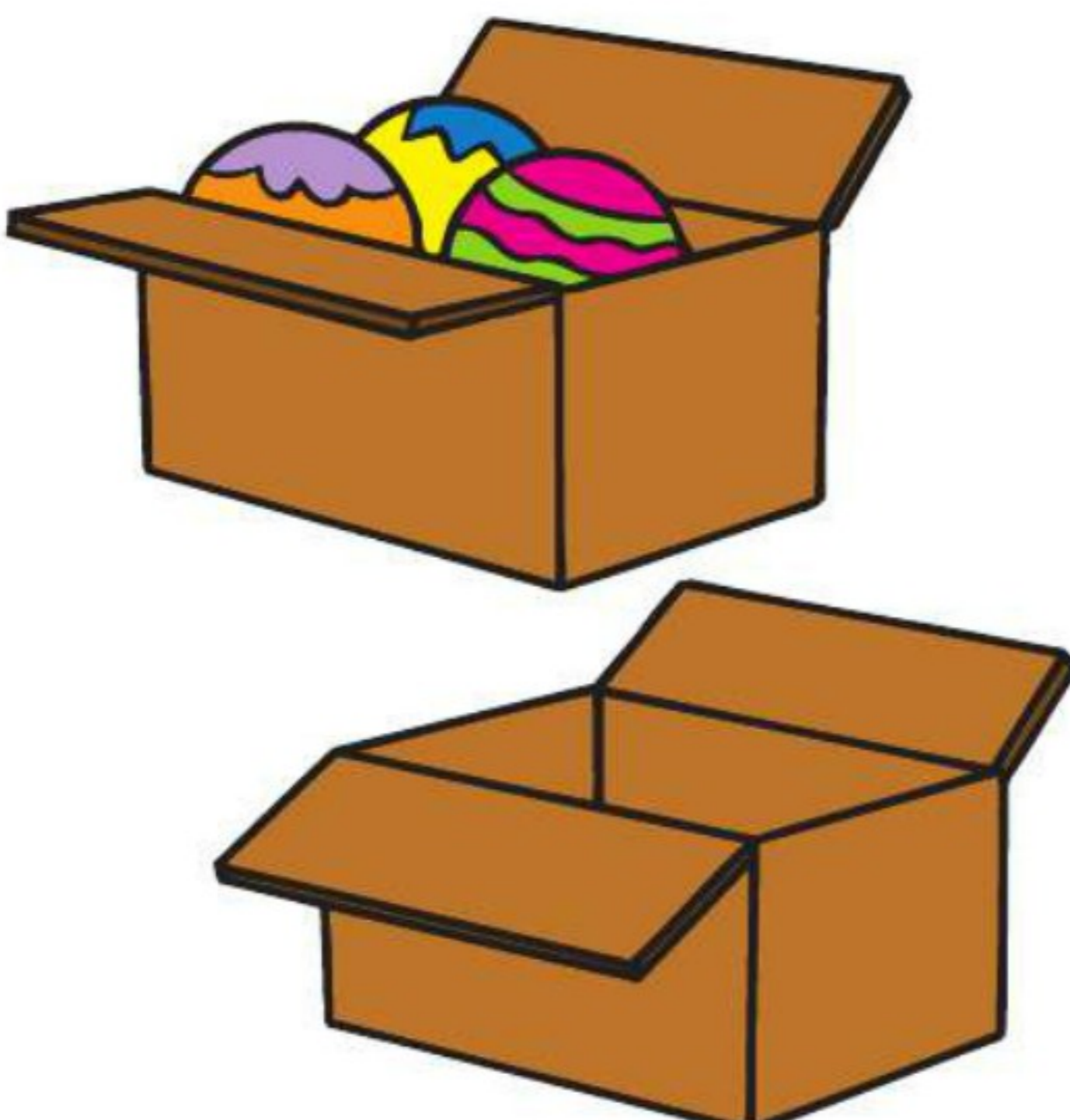

# More Full and Empty

**Directions:** Circle  the full container. Draw an X  on the empty container.



# Night and Day

**Directions:** Circle  the things you usually do at night.



**Directions:** Draw  and color  a picture of something you do only in the day.

Name \_\_\_\_\_

OPPOSITES



## Match Opposites

**Directions:** Draw  a line to match each picture with its opposite.



full

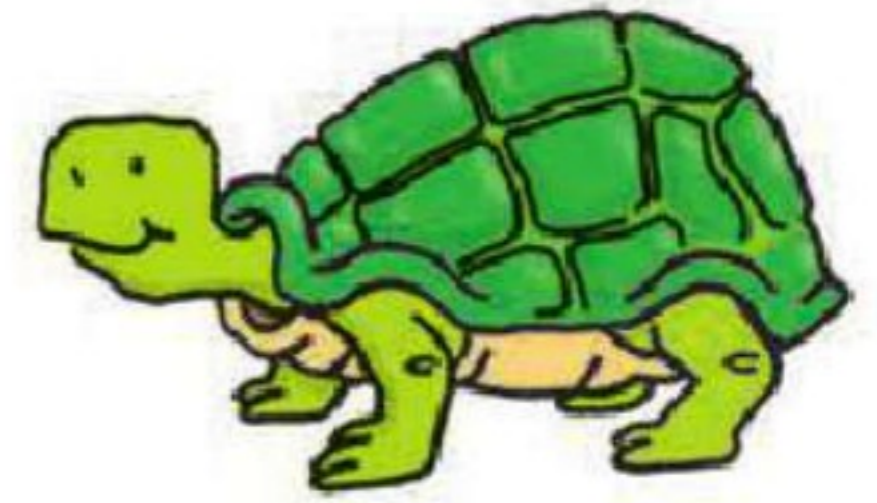

out

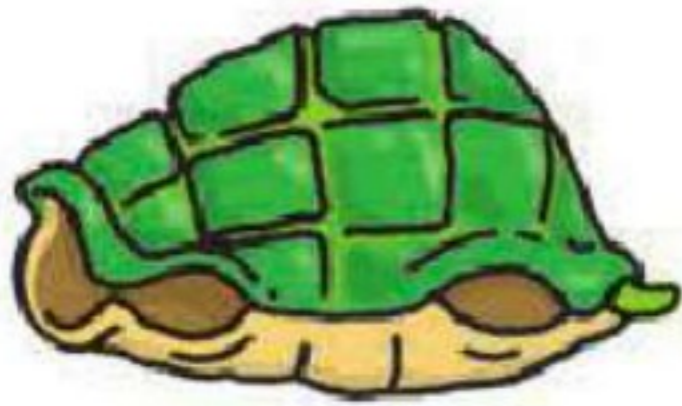

in



short



tall



empty



# Draw Opposites

**Directions:** Draw  a picture of the opposite.

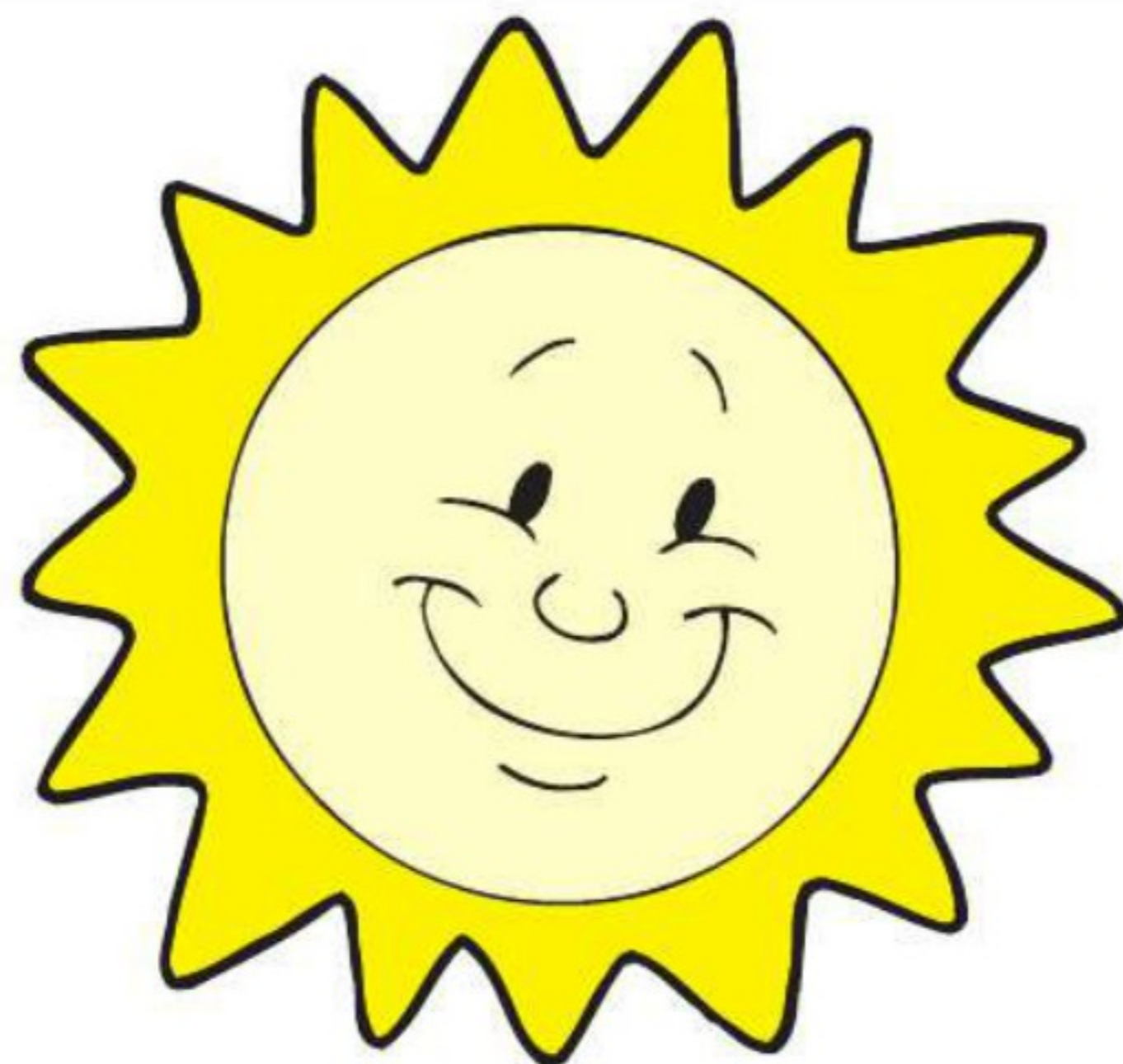

day

night

Name \_\_\_\_\_

OPPOSITES



# Draw Opposites

**Directions:** Draw  a picture of the opposite.



sad

happy



## Hot and Cold

Miriam's mom just made breakfast. What things are hot on the table? What things are cold?

**Directions:** Circle  all the **hot** things with a **red** crayon.

**Circle**  all the **cold** things with a **blue** crayon.



What would you eat for breakfast if you were Miriam?



# Fast and Slow

Look at the pictures below.

**Directions:** Circle  all the things that go **fast**.

Draw an **X**  on each thing that goes **slow**.

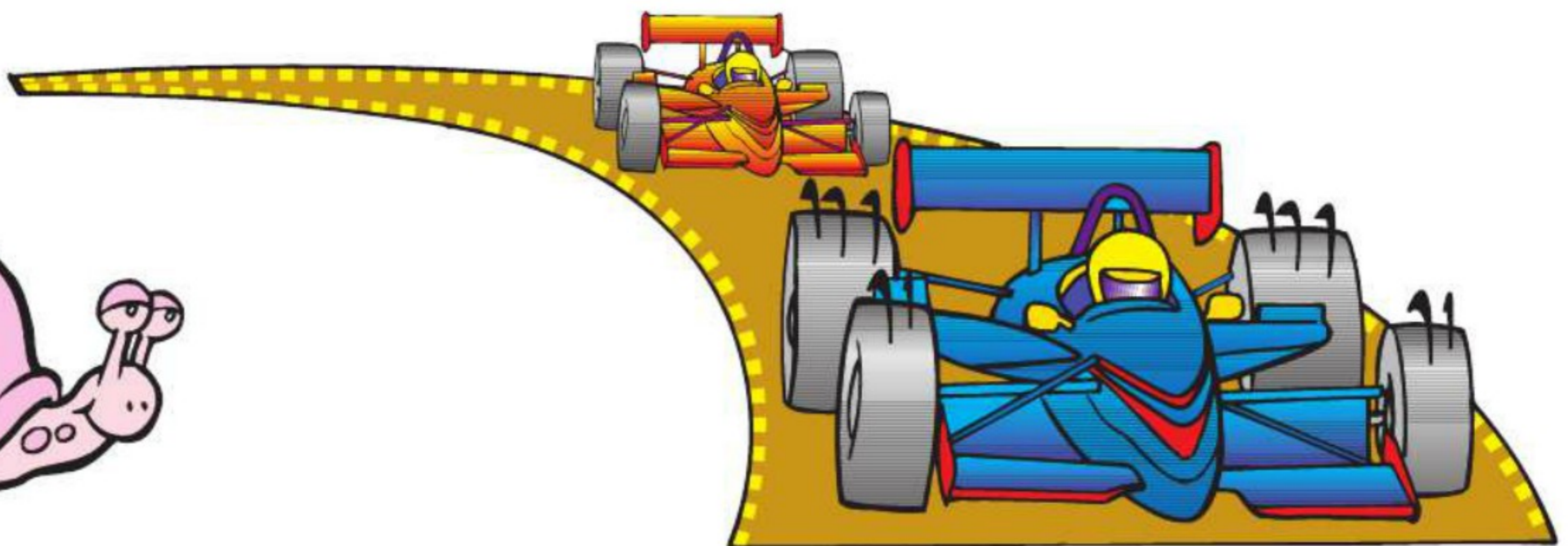
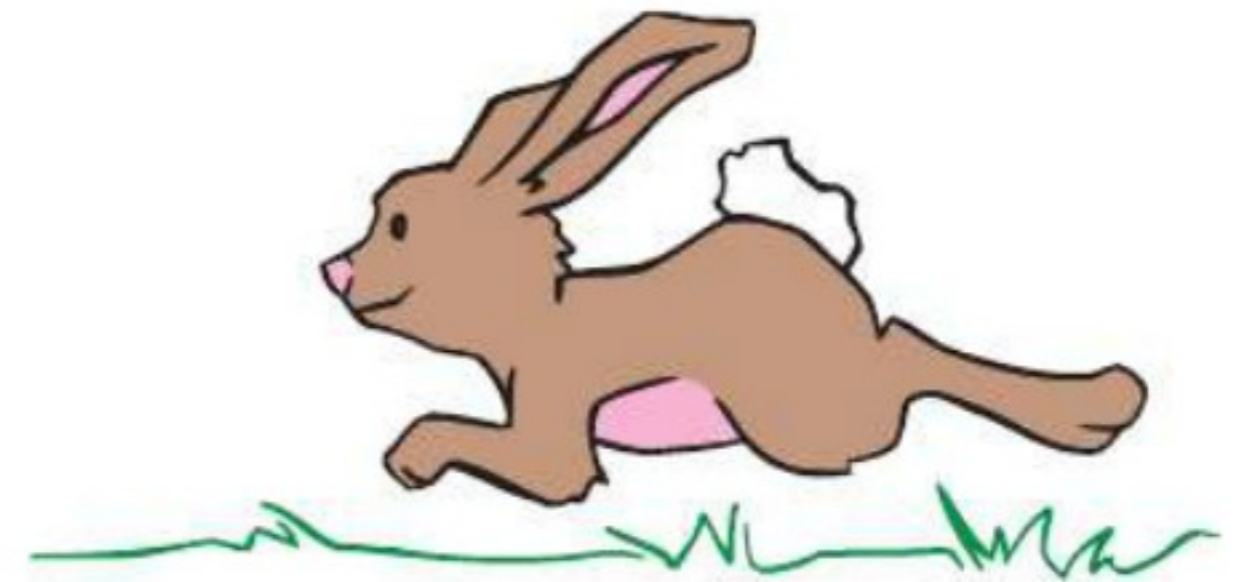



# Match Opposites

**Directions:** Draw  a line to match each picture with its opposite.



left



sad



above



right



happy

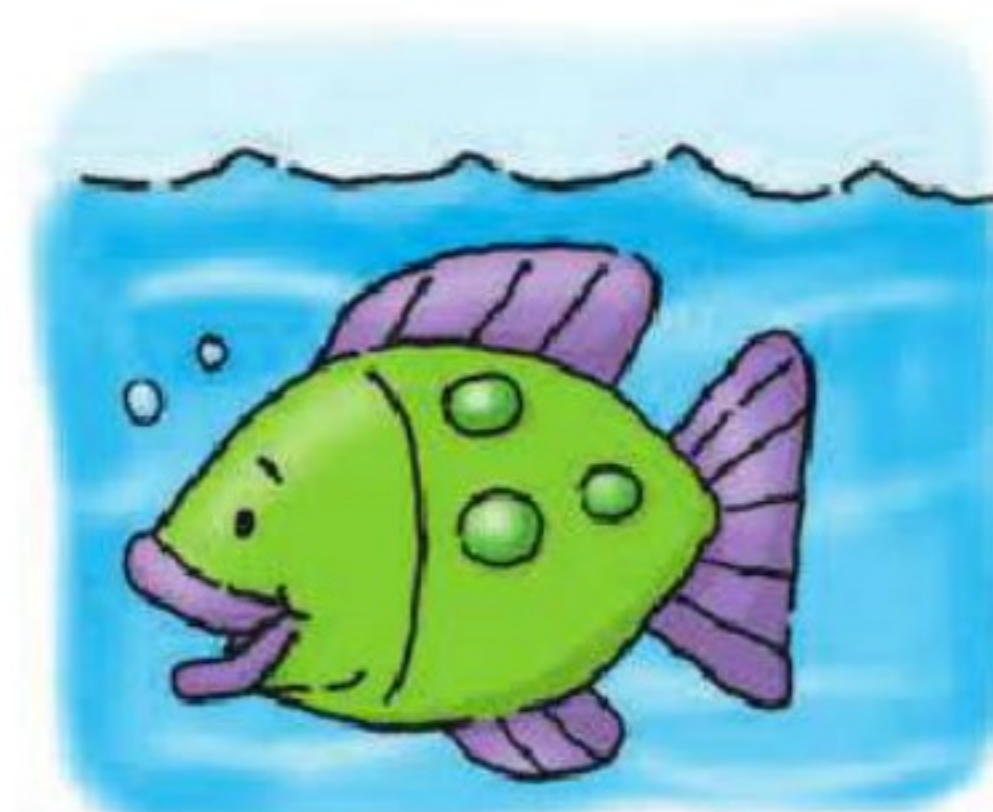

below



Name \_\_\_\_\_



# More Opposites

**Directions:** Draw  a line to match each picture to its opposite.





# In the Tree

**Directions:** Draw  lines to connect the tree to the things you might find in a tree.

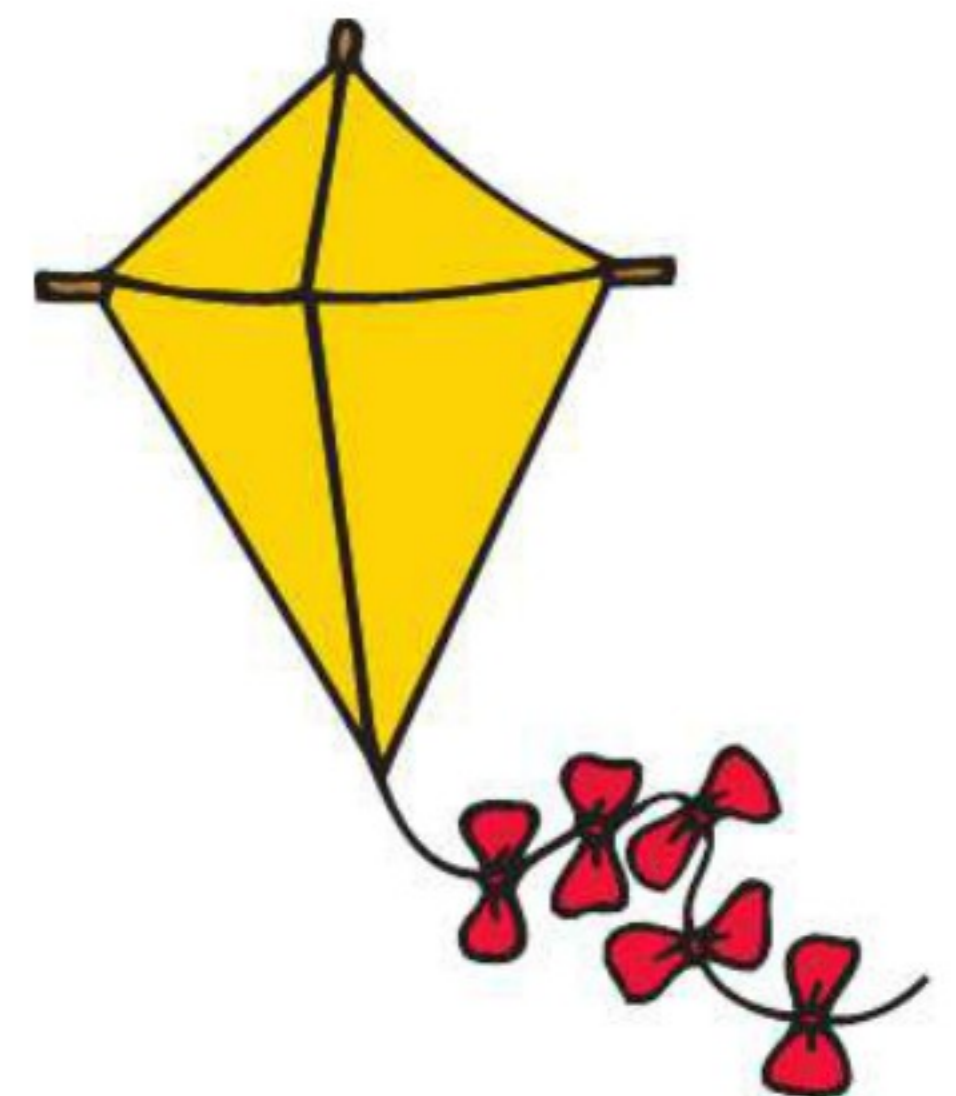
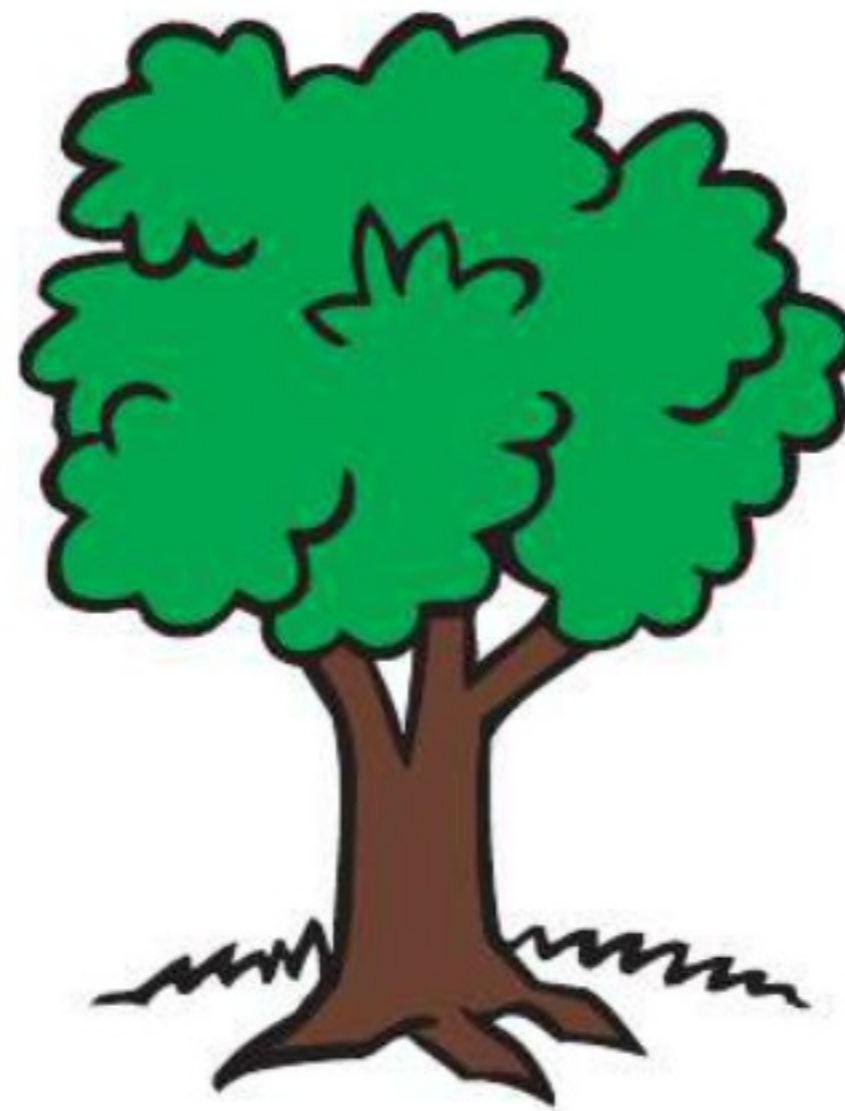

**Note to Parents:** Talk with your child about the choices he or she made. Check out the trees in your neighborhood to see what you can find.

Name \_\_\_\_\_

CLASSIFYING



# We Go Together



**Directions:** Draw  lines to match the things that go together.



**Note to Parents:** Talk with your child about the choices he or she made.



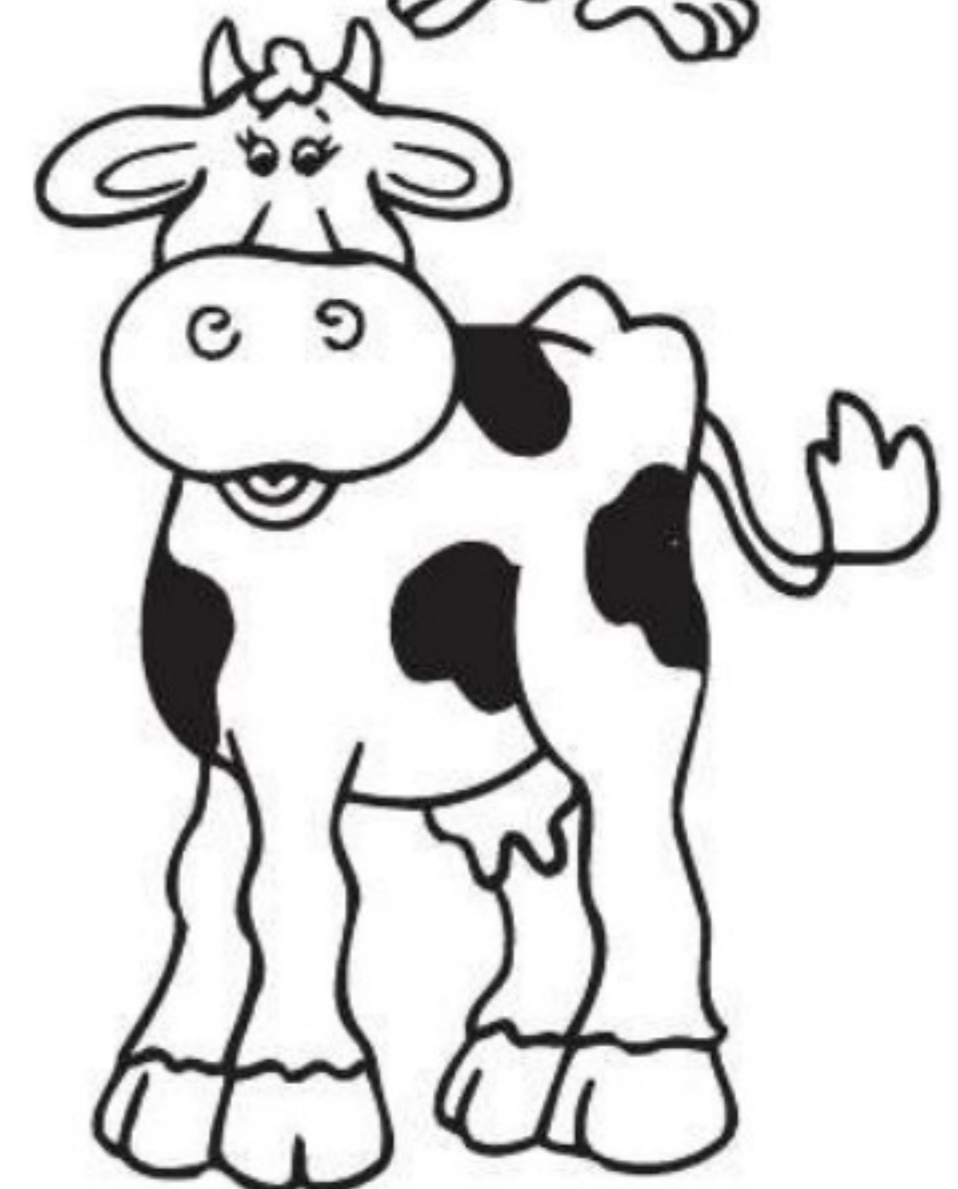
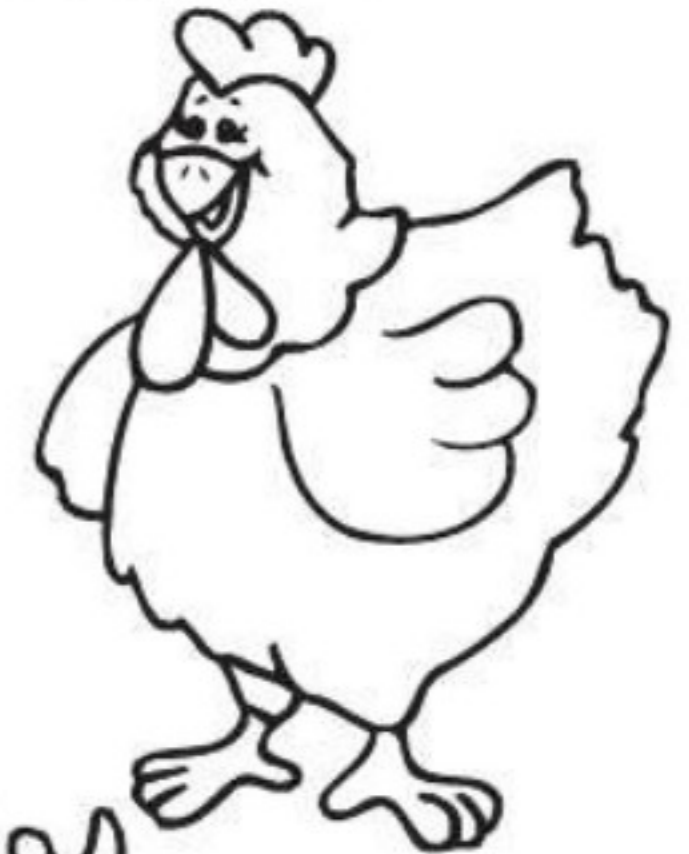
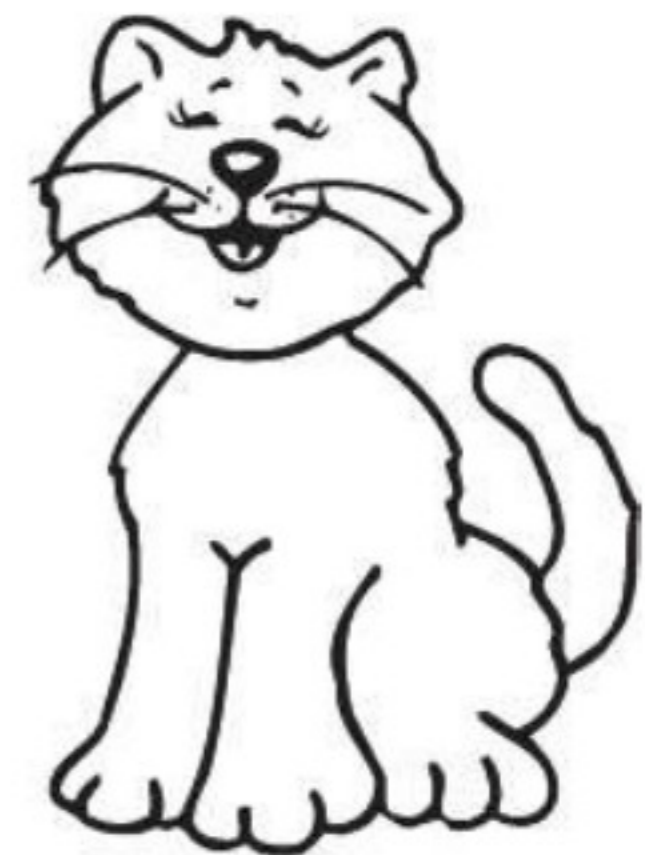
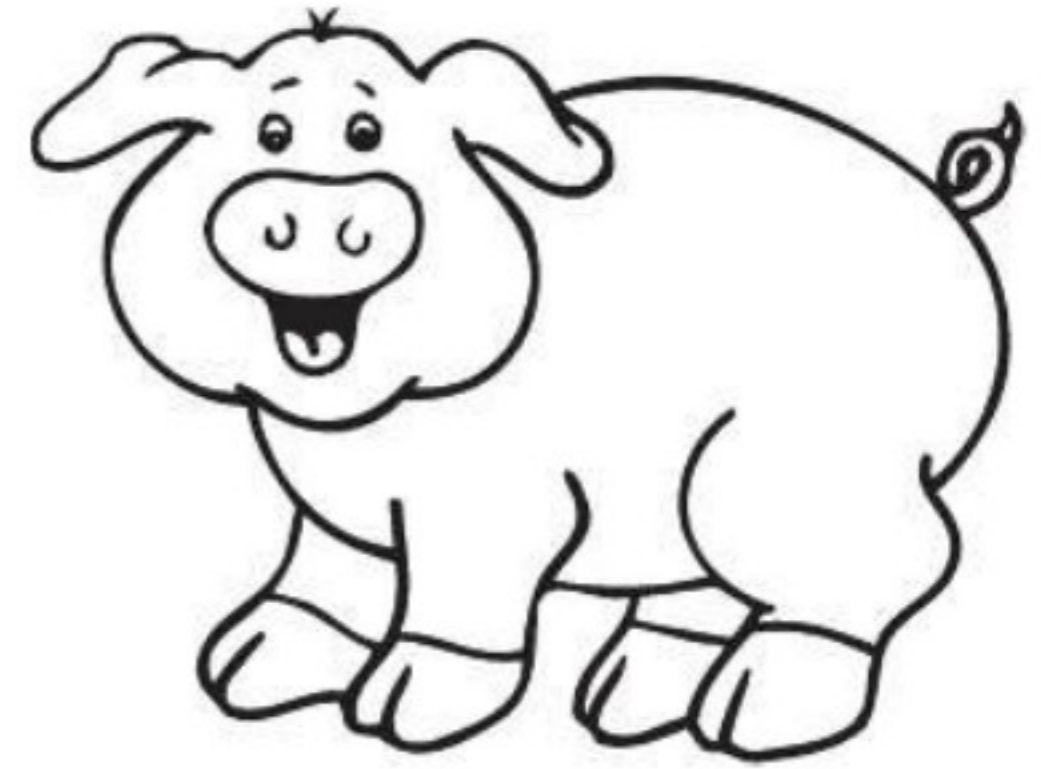
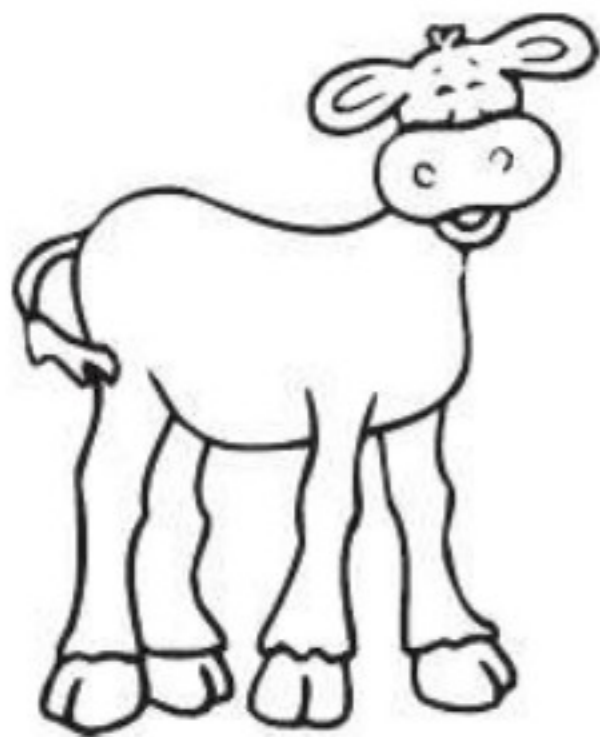
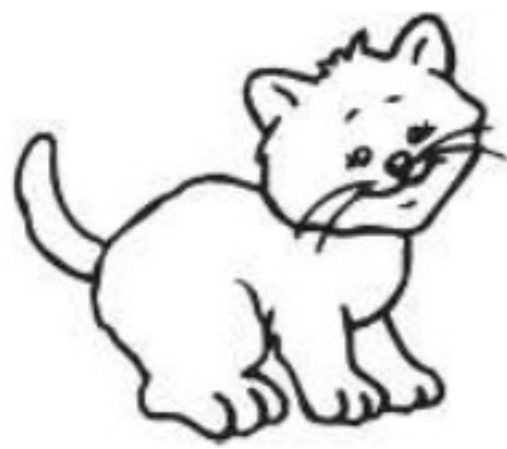

# Baby Animals

**Directions:** Draw  a line to match each baby animal to its parent. **Color**  the pictures.





## What Belongs?

**Directions:** Draw a **red X**  on the animals that do not belong in the picture. **Color**  the animals that do belong.

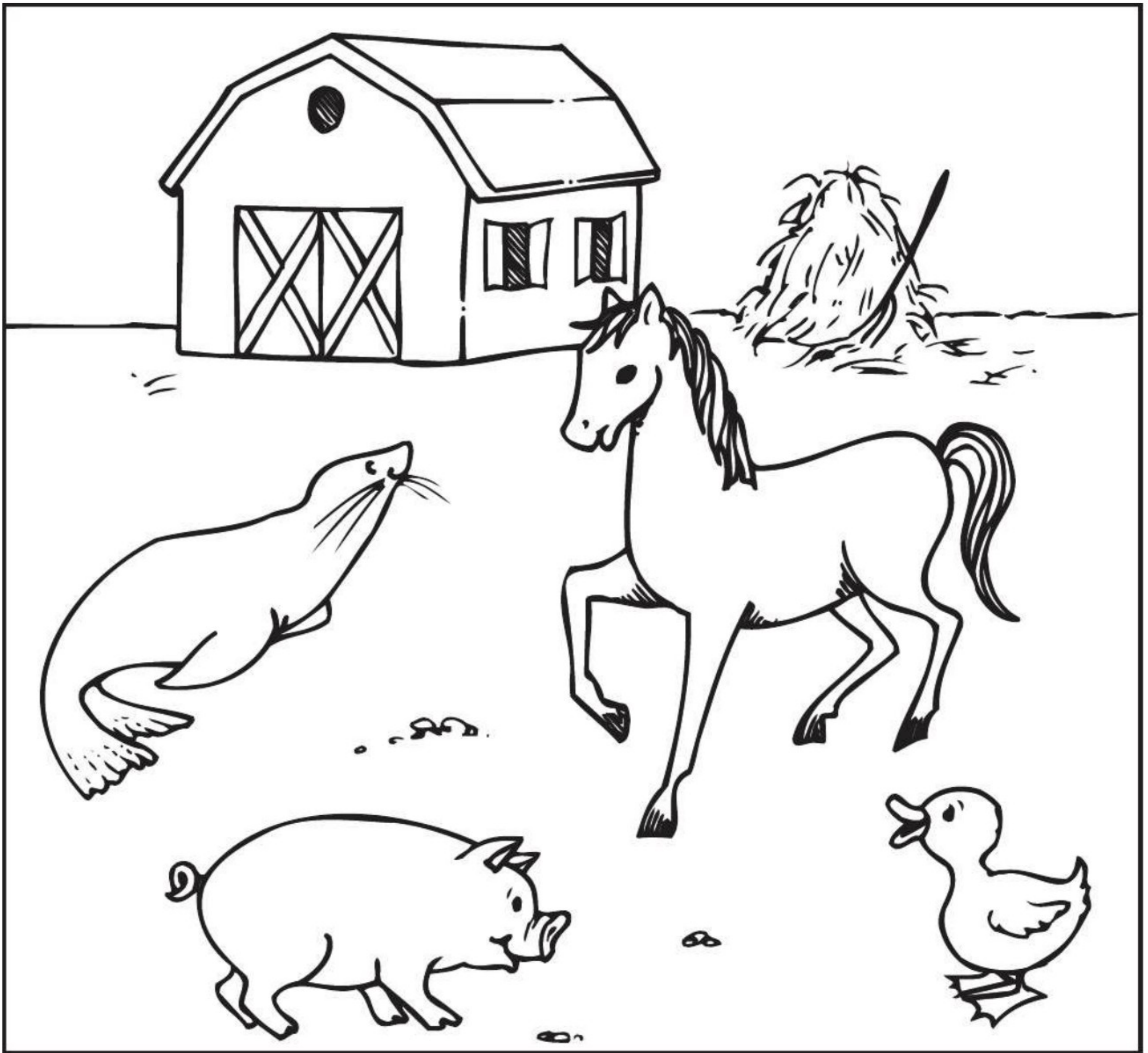

**Note to Parents:** Talk with your child about his or her selections. Sort toy animals according to where they live: forest, jungle, ocean, desert, etc.



# Part of a Group

**Directions:** Pick **3** pictures that go together in each group. Draw an **X**  on the picture that does not belong in the group.

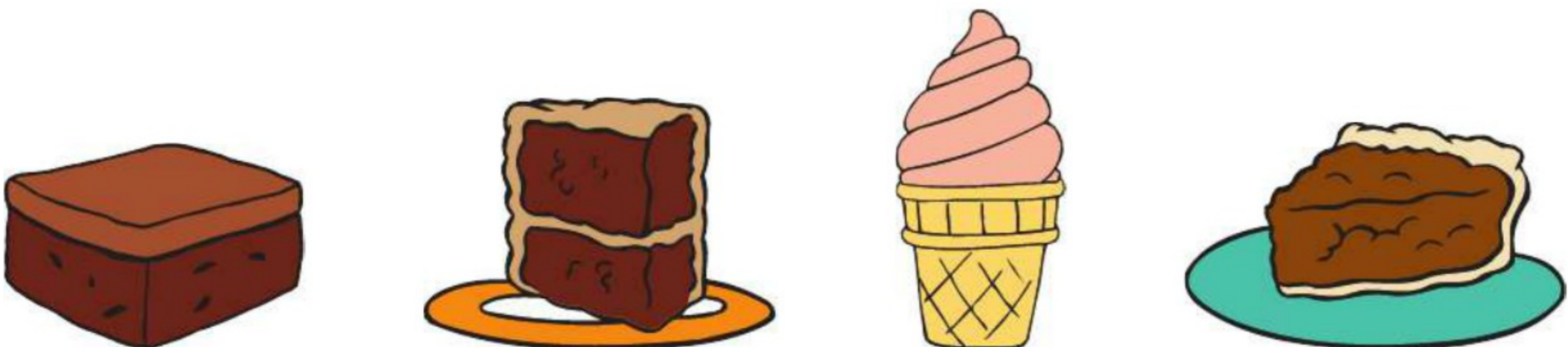
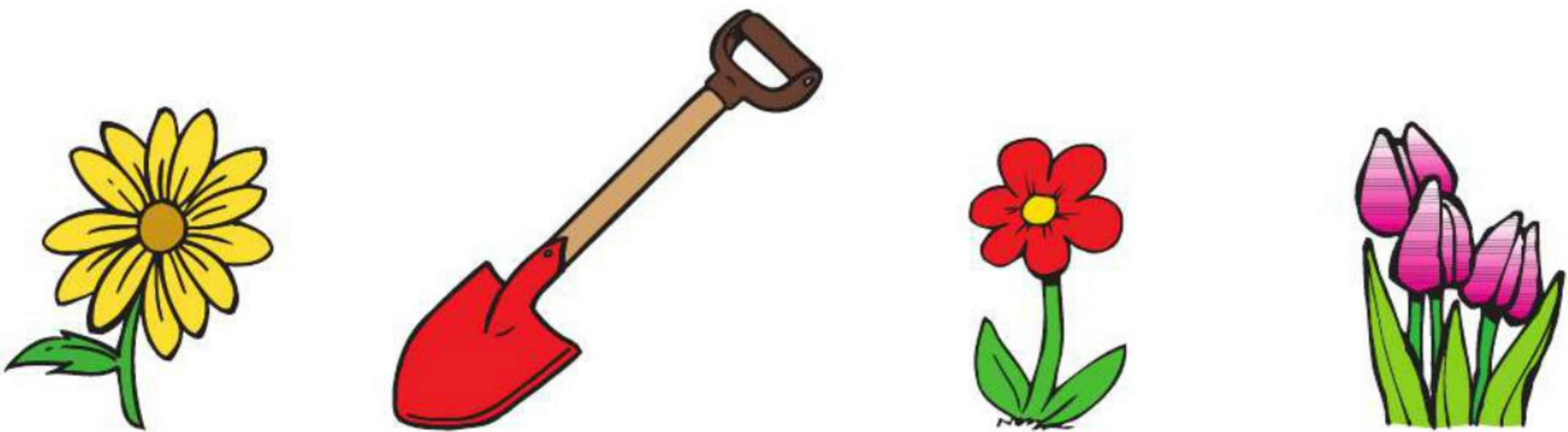



# Three Things

**Directions:** Circle  your answers below.

Which 3 things are on your face?

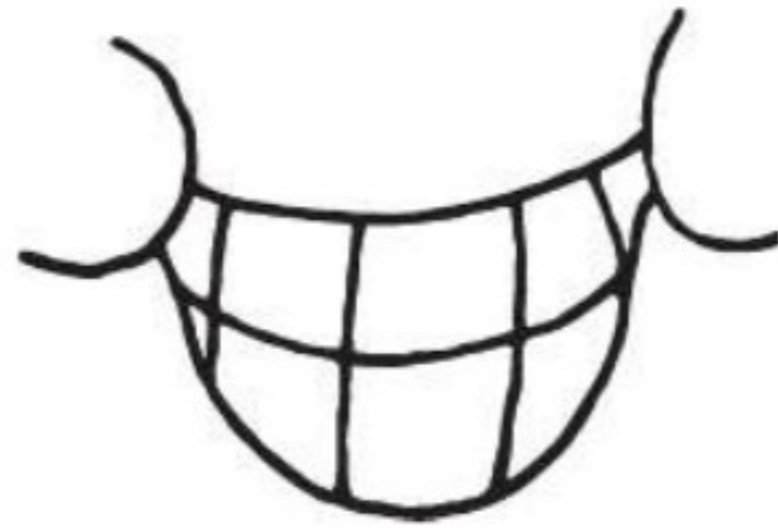
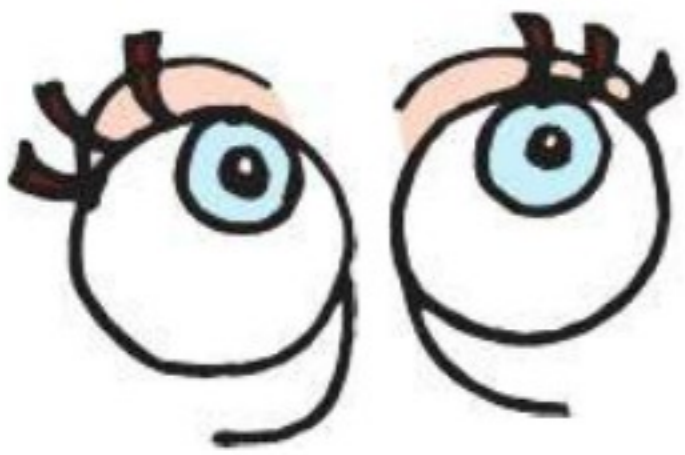

Which 3 things would you need to sleep?

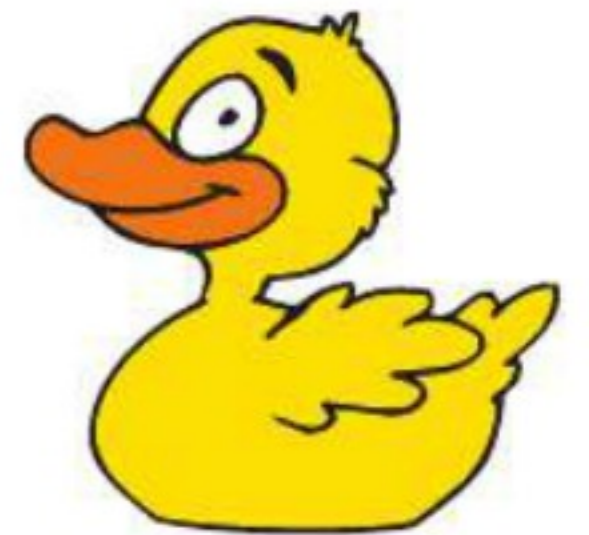
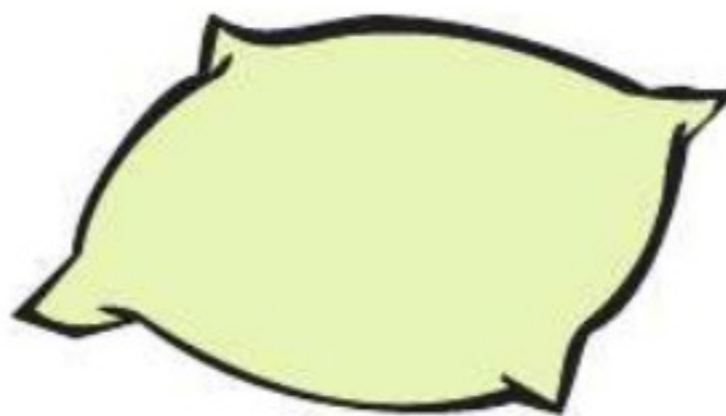

Which 3 animals like to go in the water?

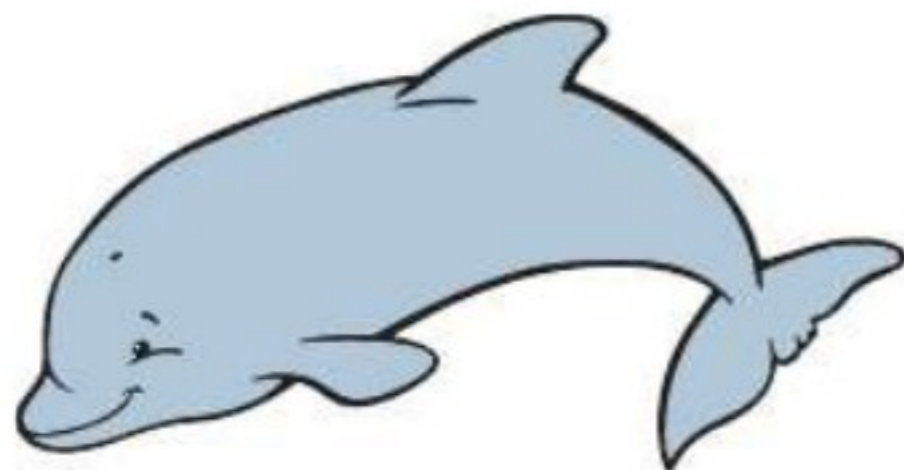
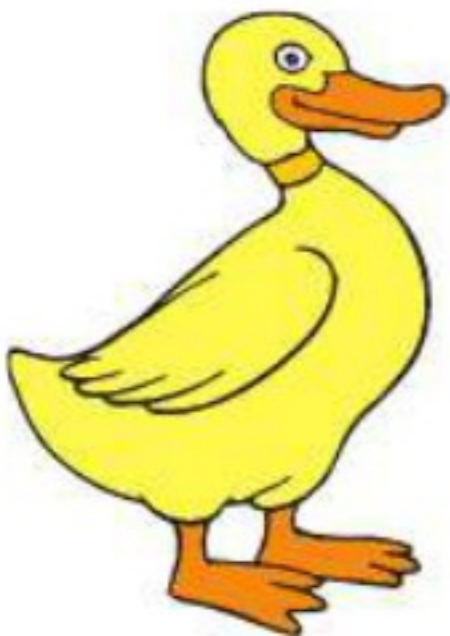



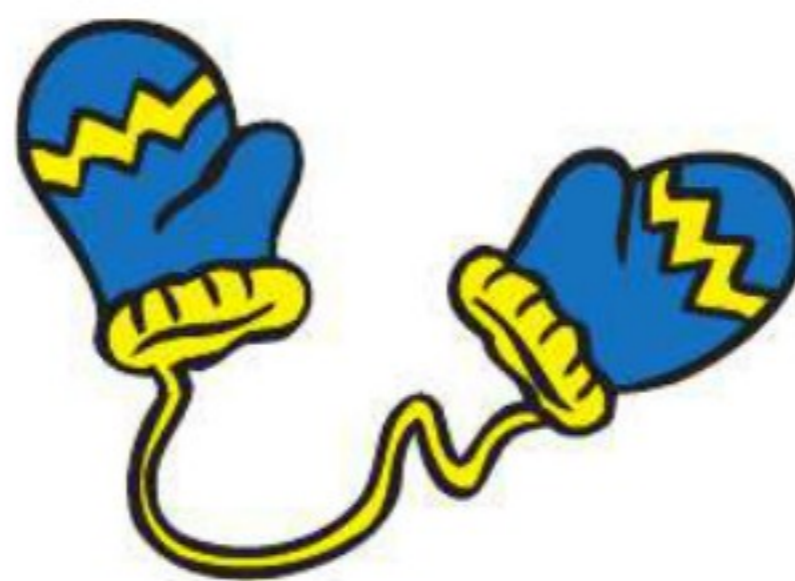





Which 3 things would you wear if you were cold?

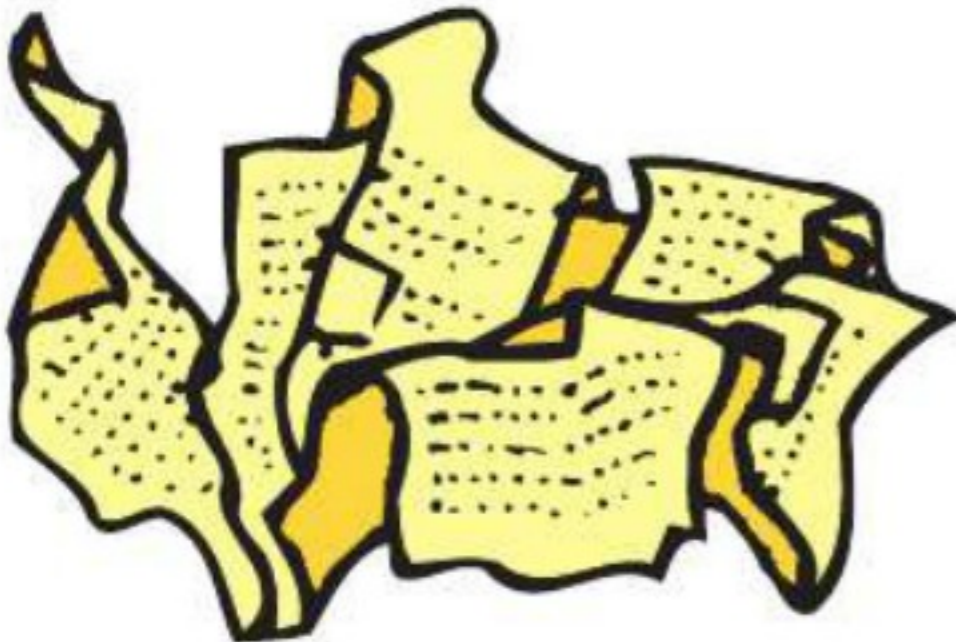
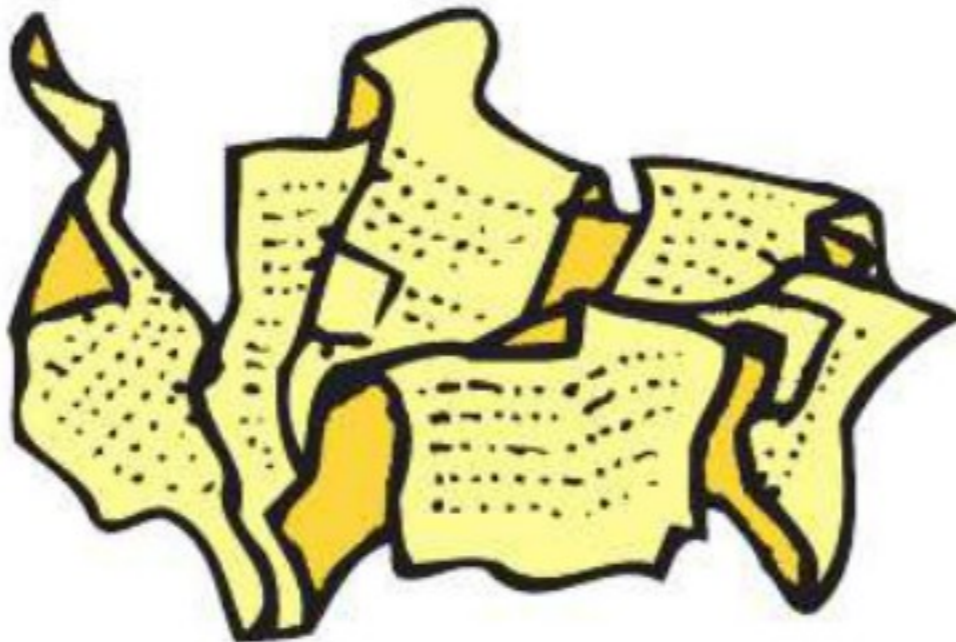



# We Are the Same

**Directions:** Circle  each picture that is the same as the first picture in the row.







		
		
		



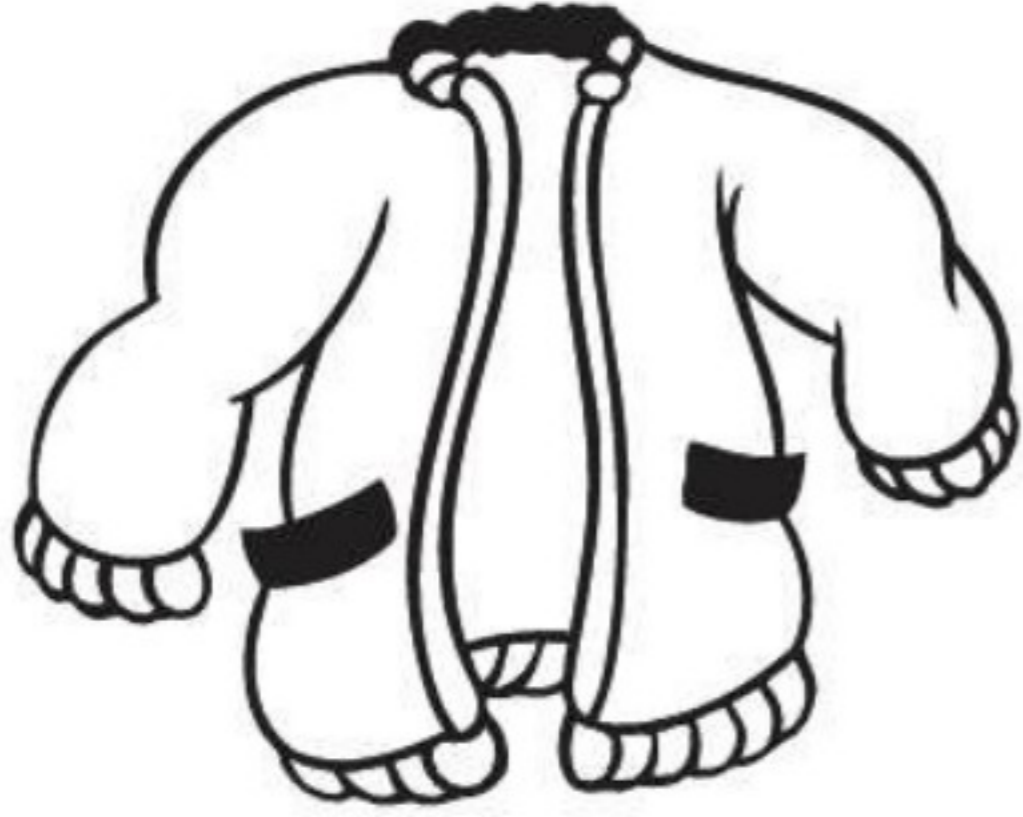
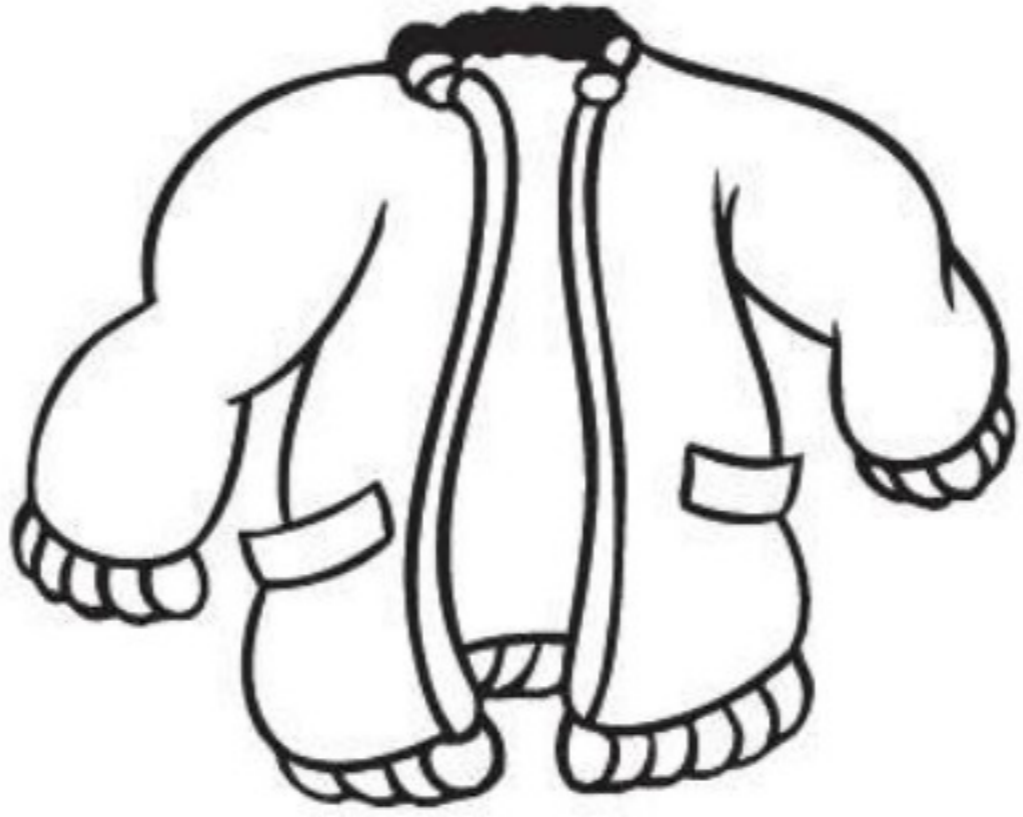
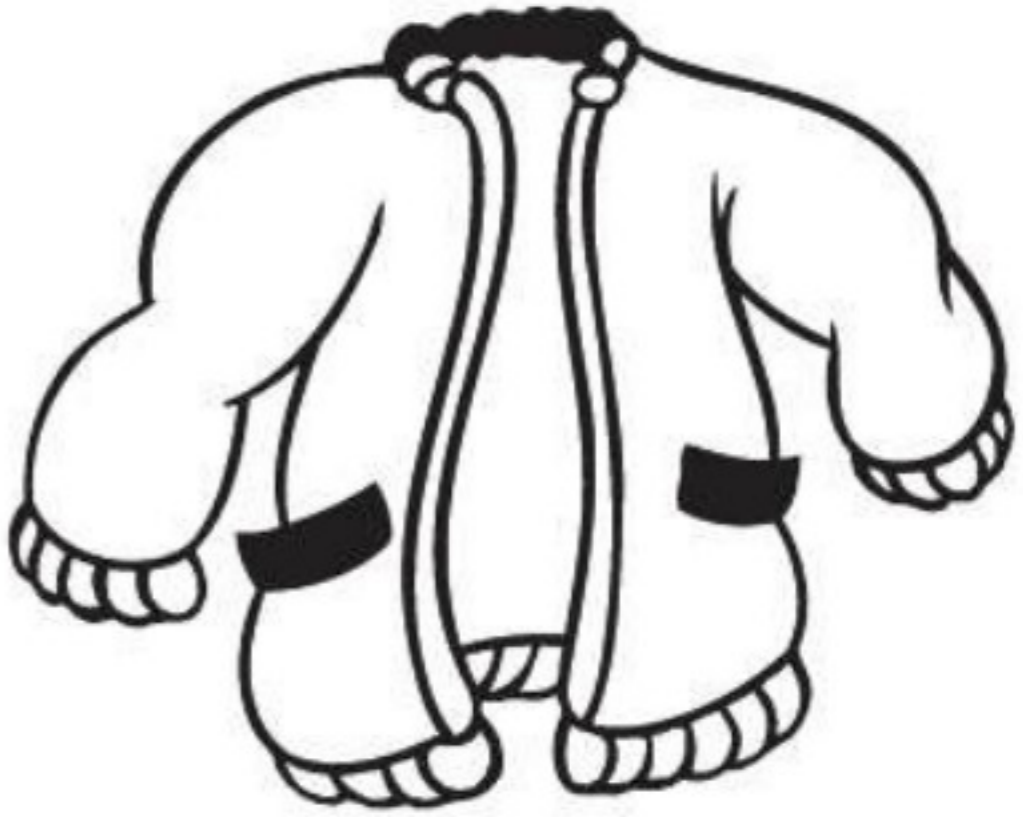

# Color the Same Things

**Directions:** Color  the pictures in each row that are the same.



## Which One Is Different?



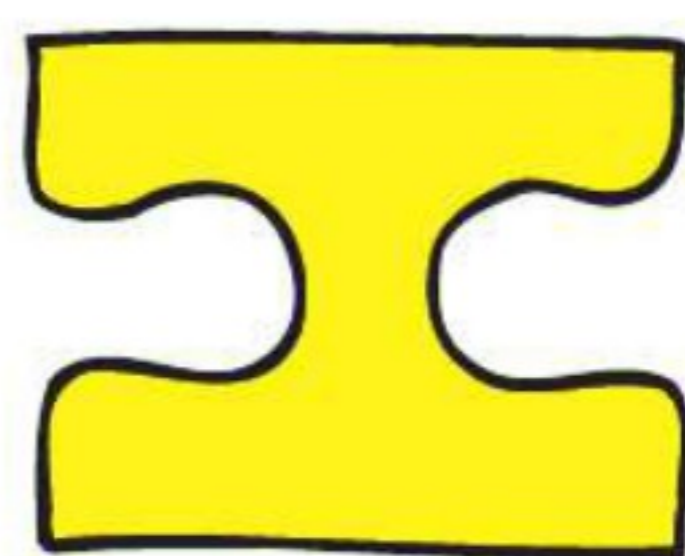
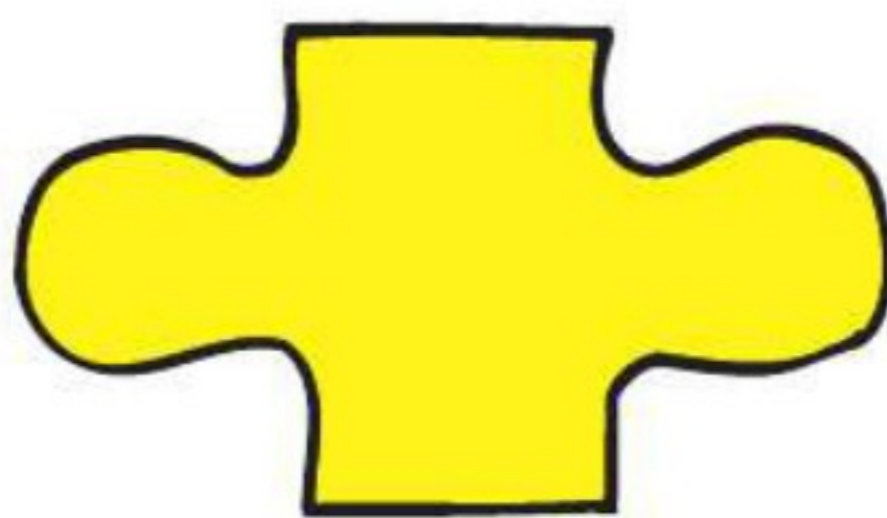
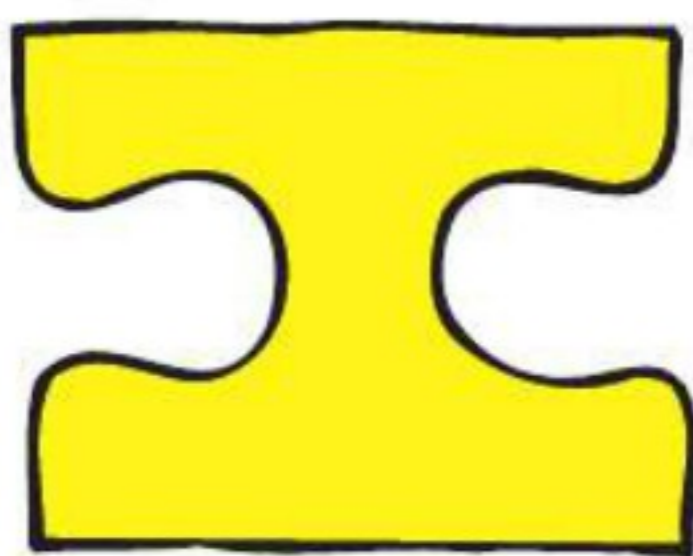
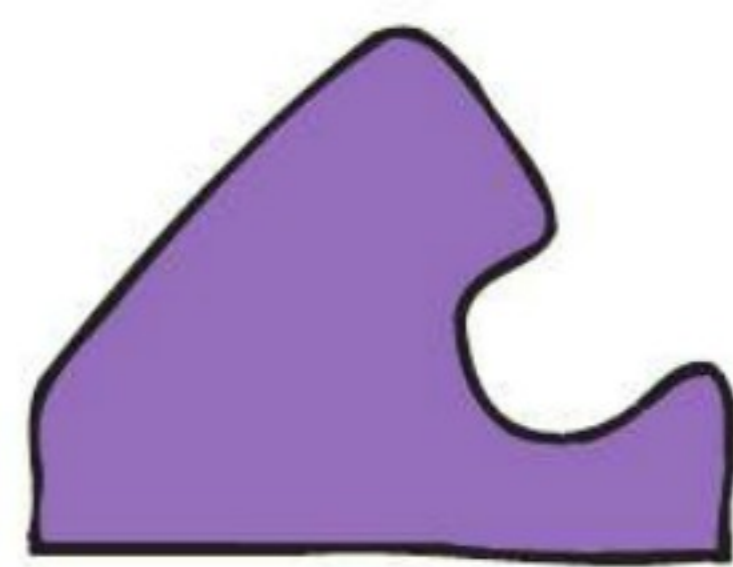
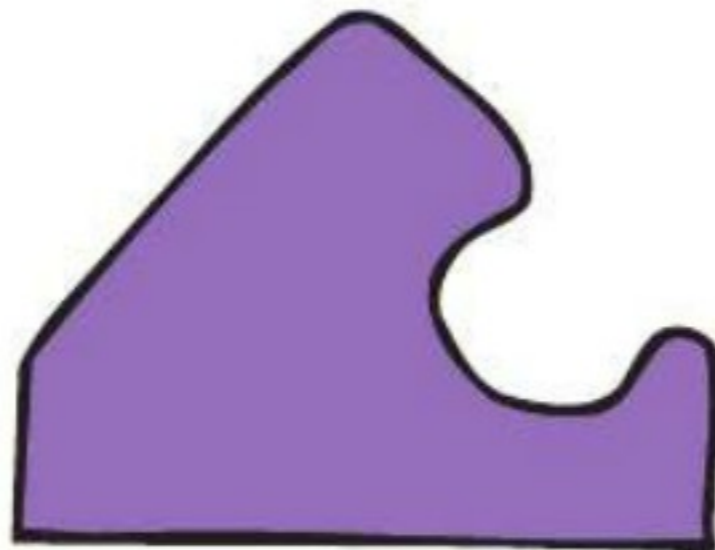
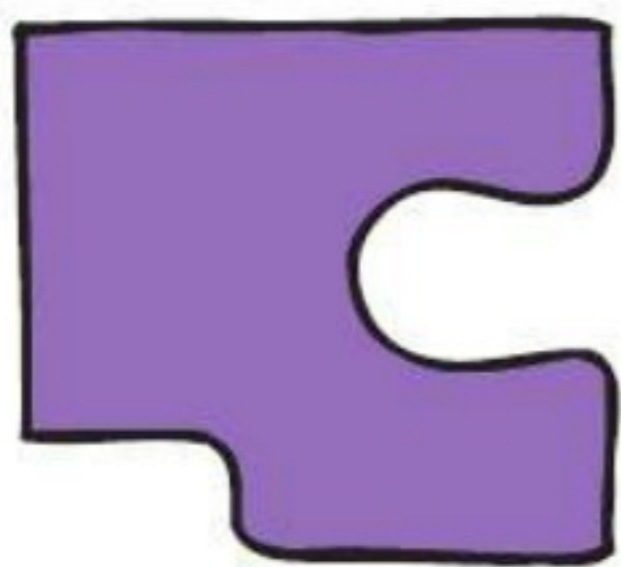
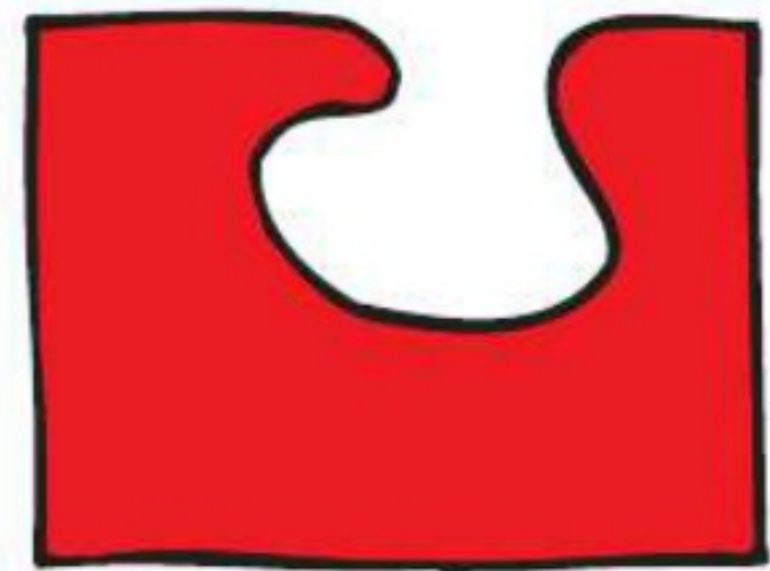
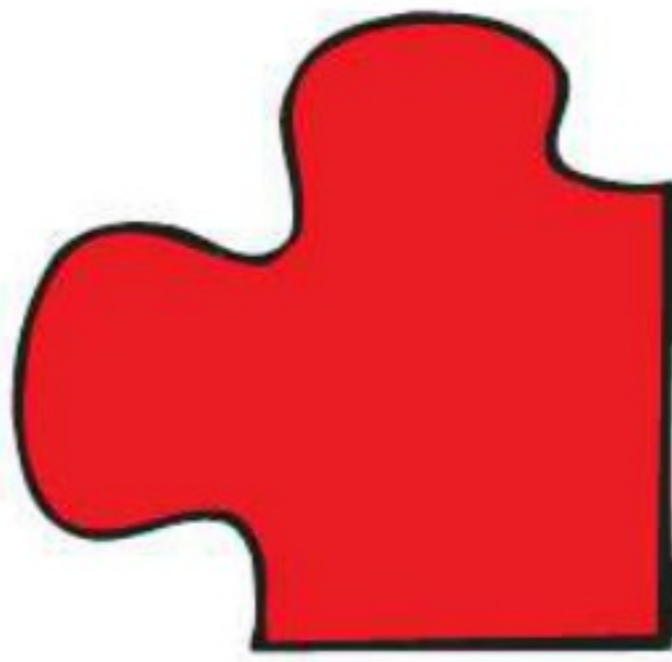
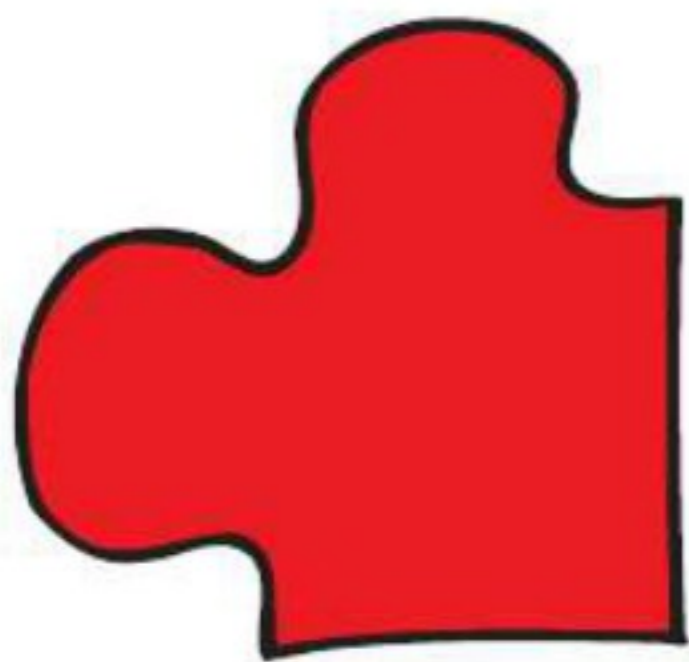

**Directions:** Circle  the puzzle piece in each row that is different.



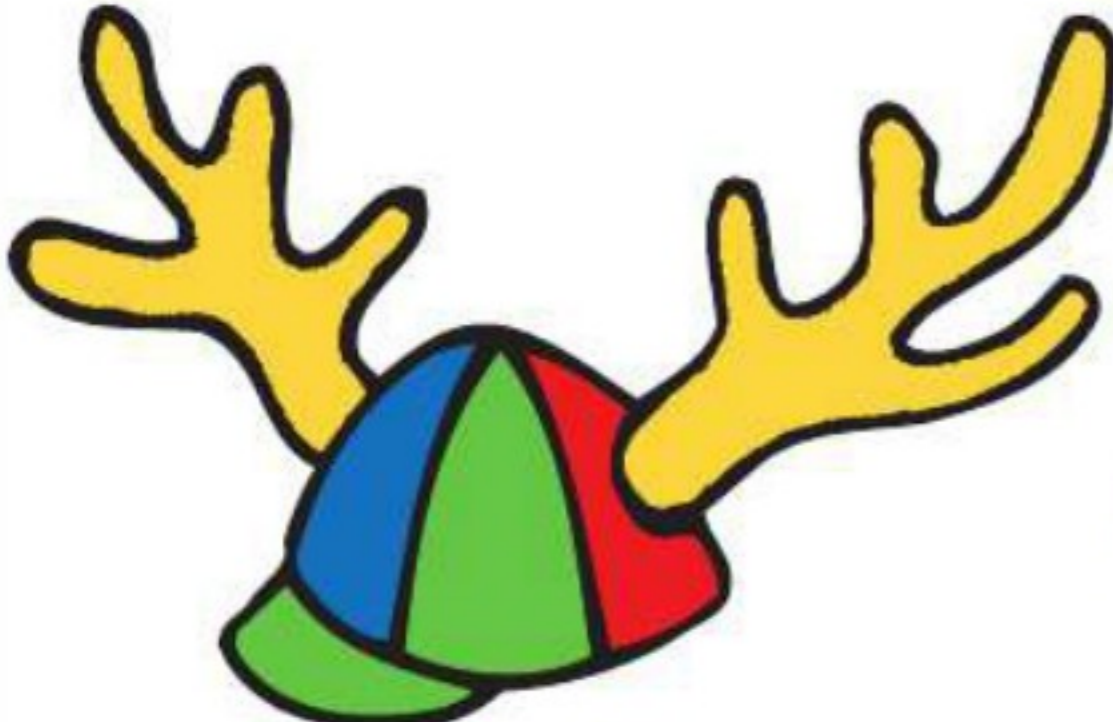
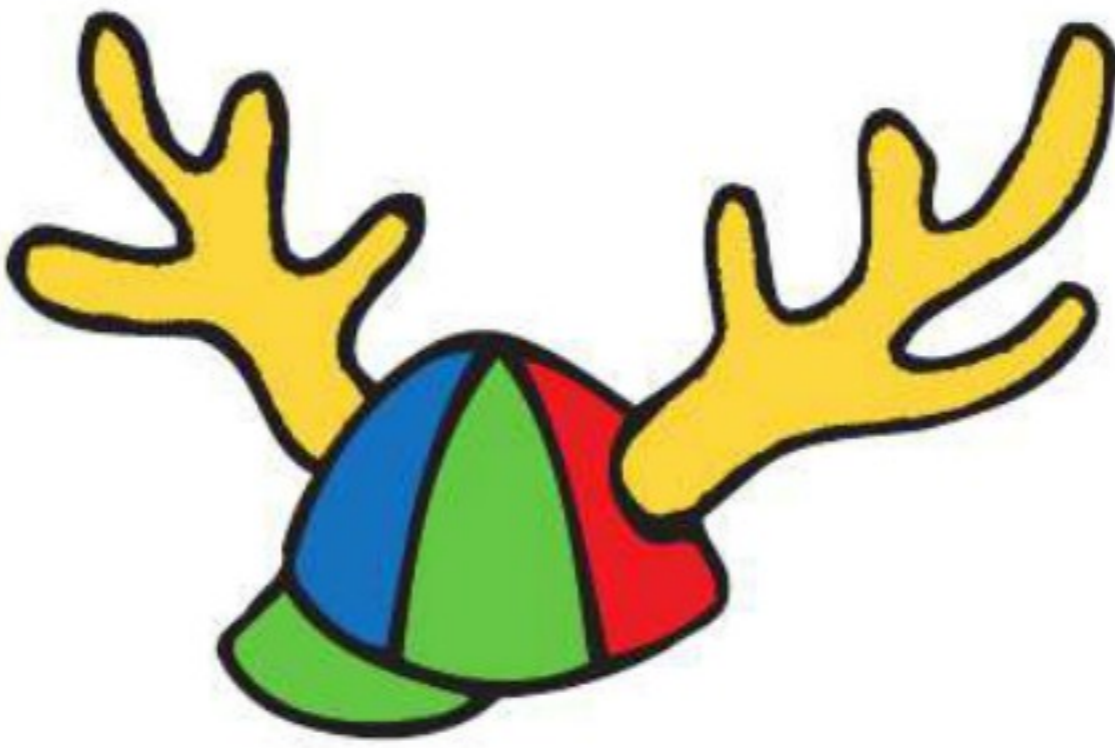
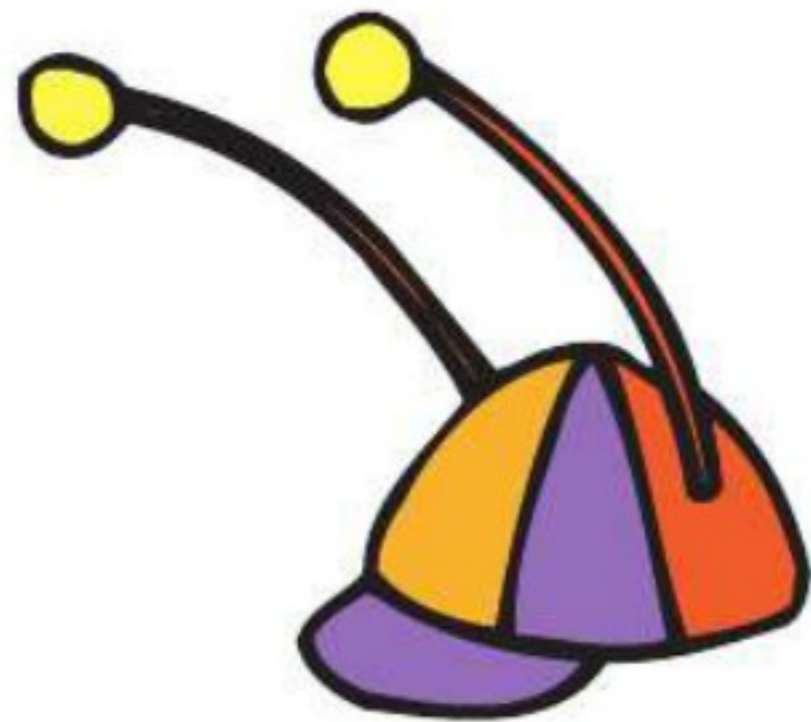
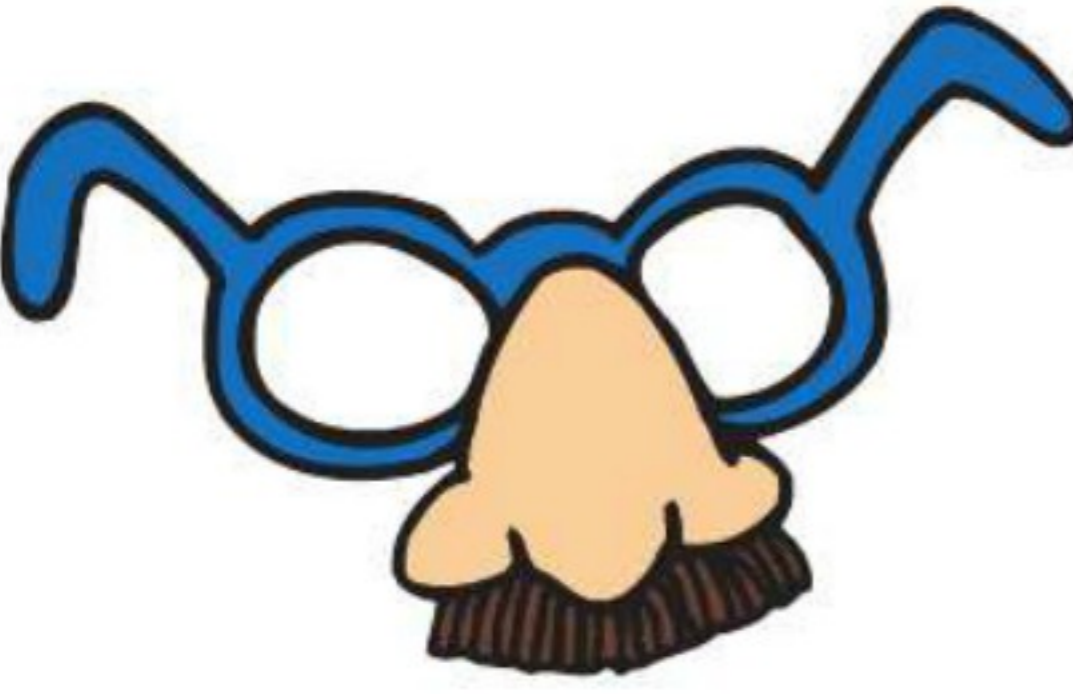

# Different Things

**Directions:** Circle  the picture in each row that is different.



## Same Words

**Directions:** Look at the words below. **Circle**  the two words in each row that are the same. The first one shows you what to do.





## More of the Same

**Directions:** Look at the words below. **Circle**  the word that is the same as the first word in the row. The first one shows you what to do.

bug	bug	mug
-----	-----	-----



bat	bat	mat
-----	-----	-----

pin	tin	pin
-----	-----	-----

jam	ham	jam
-----	-----	-----



# Same Objects

**Directions:** Circle  the mug to show it is the same as the first mug. Circle  the object that is the same in each row.

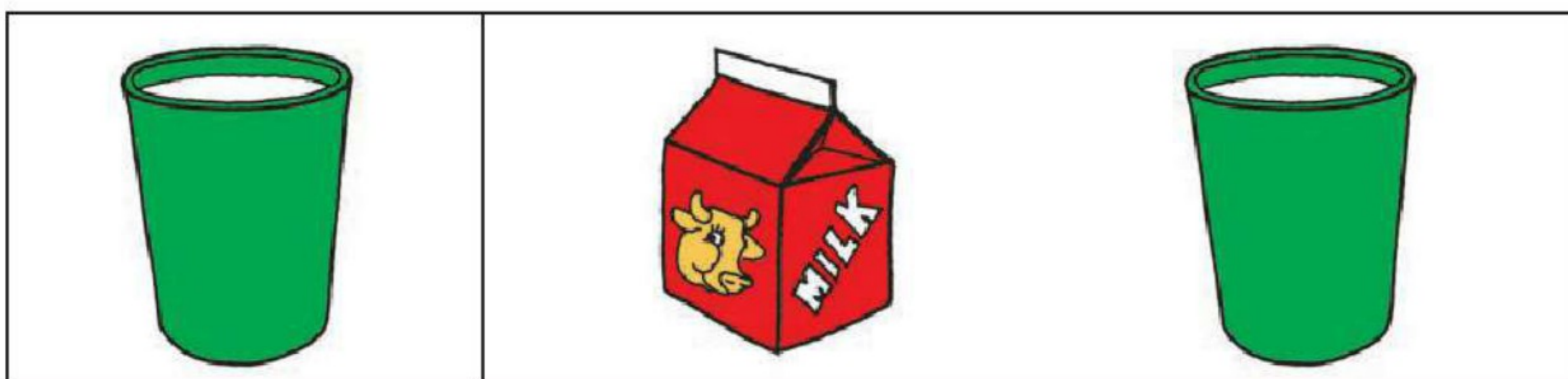
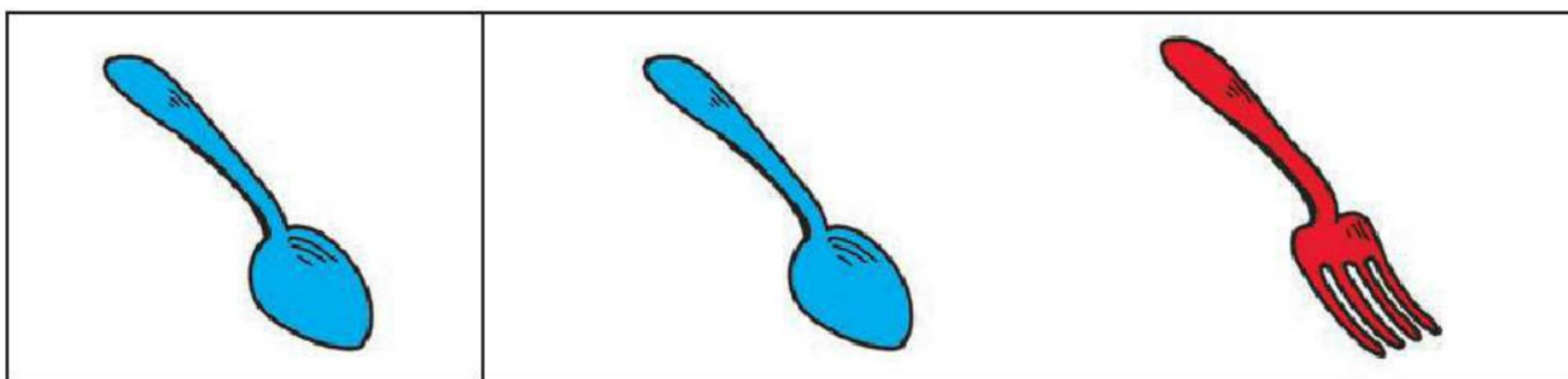
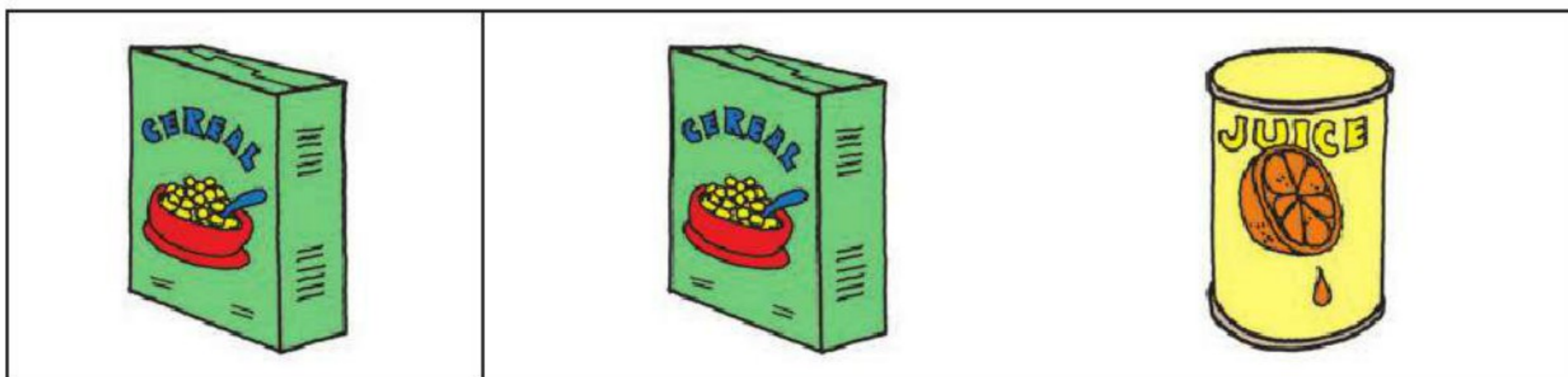
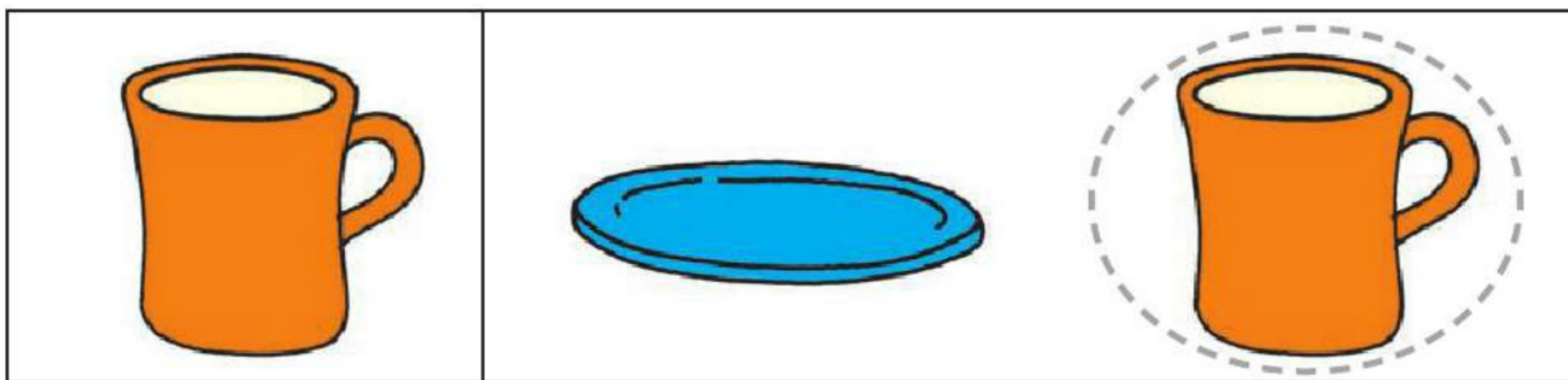



## Pam's Purple Shoes

Pam loves to wear purple shoes. All her shoes are purple!

**Directions:** Draw  a line connecting each pair of matching shoes.



Which pair of shoes should Pam wear to the beach? Which pair of shoes should she wear with her pajamas?

**Circle**  your favorite pair of shoes above.



## Cats and Dogs

Look at the cat and dog below. Can you name two ways that they are the same? Can you name two ways that they are different?

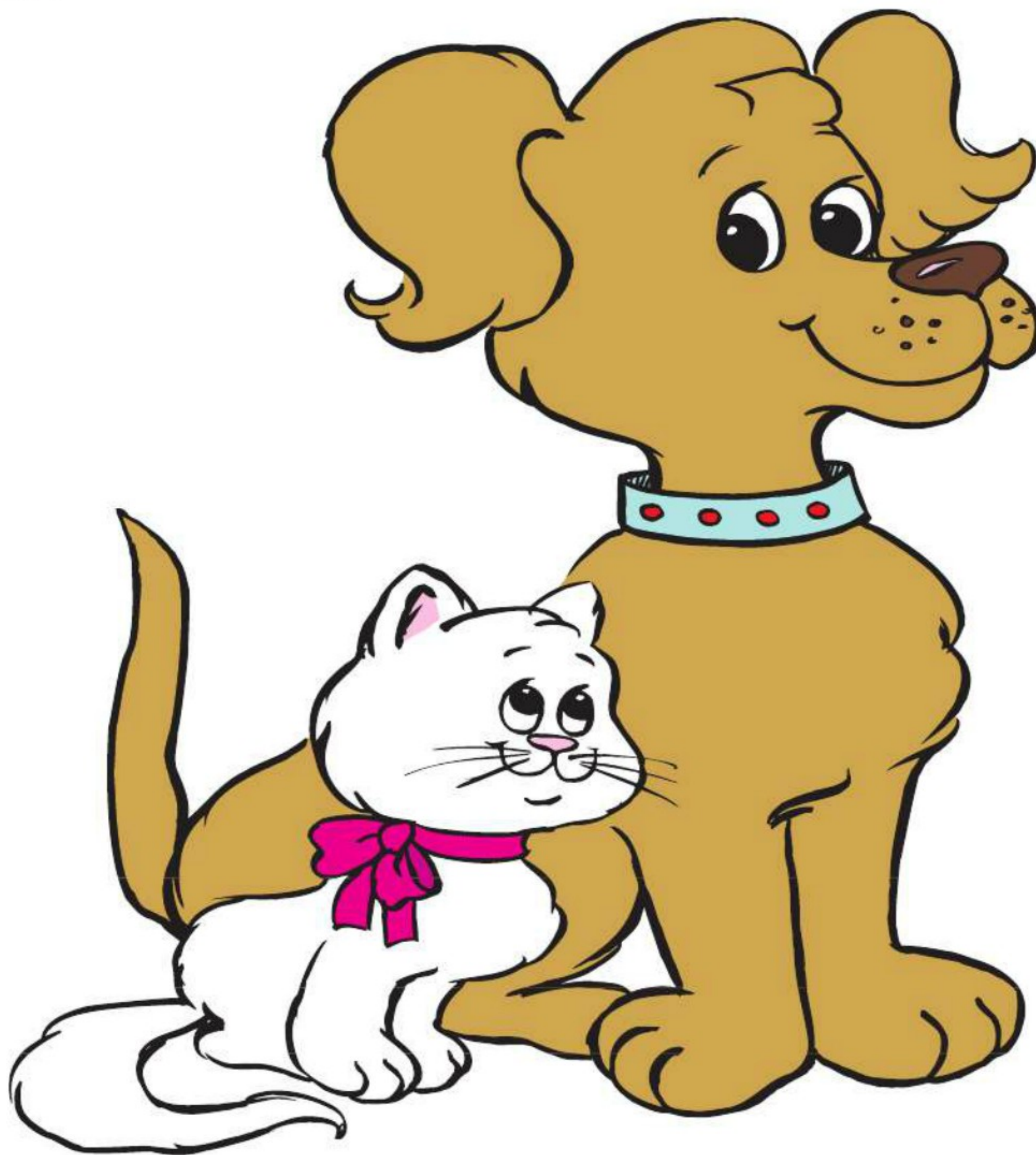

What would you name the cat? What would you name the dog? Which do you like better, the cat or the dog?

**Directions:** Circle  the one you like the most.





## Mama Bear

A baby bear is called a cub. Each cub looks like its mother.

**Directions:** Draw  a line to match each cub to its mama bear.

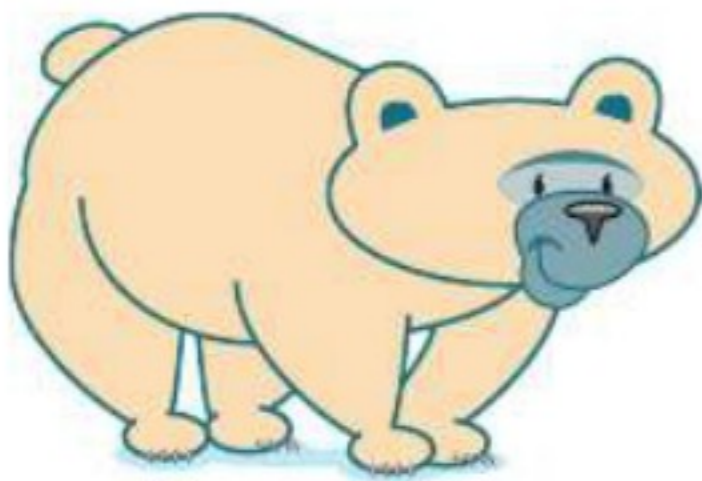

Did you know that bears hibernate in the winter?  
 What color are the bears that are sleeping?  
 What is a baby bear called?  
 Are you a cub?



# Help Get Us Home

Help each animal get home!

**Directions:** Use your finger to trace a path from left to right. Then, **draw**  a line with a pencil or a crayon to connect each animal with its home.

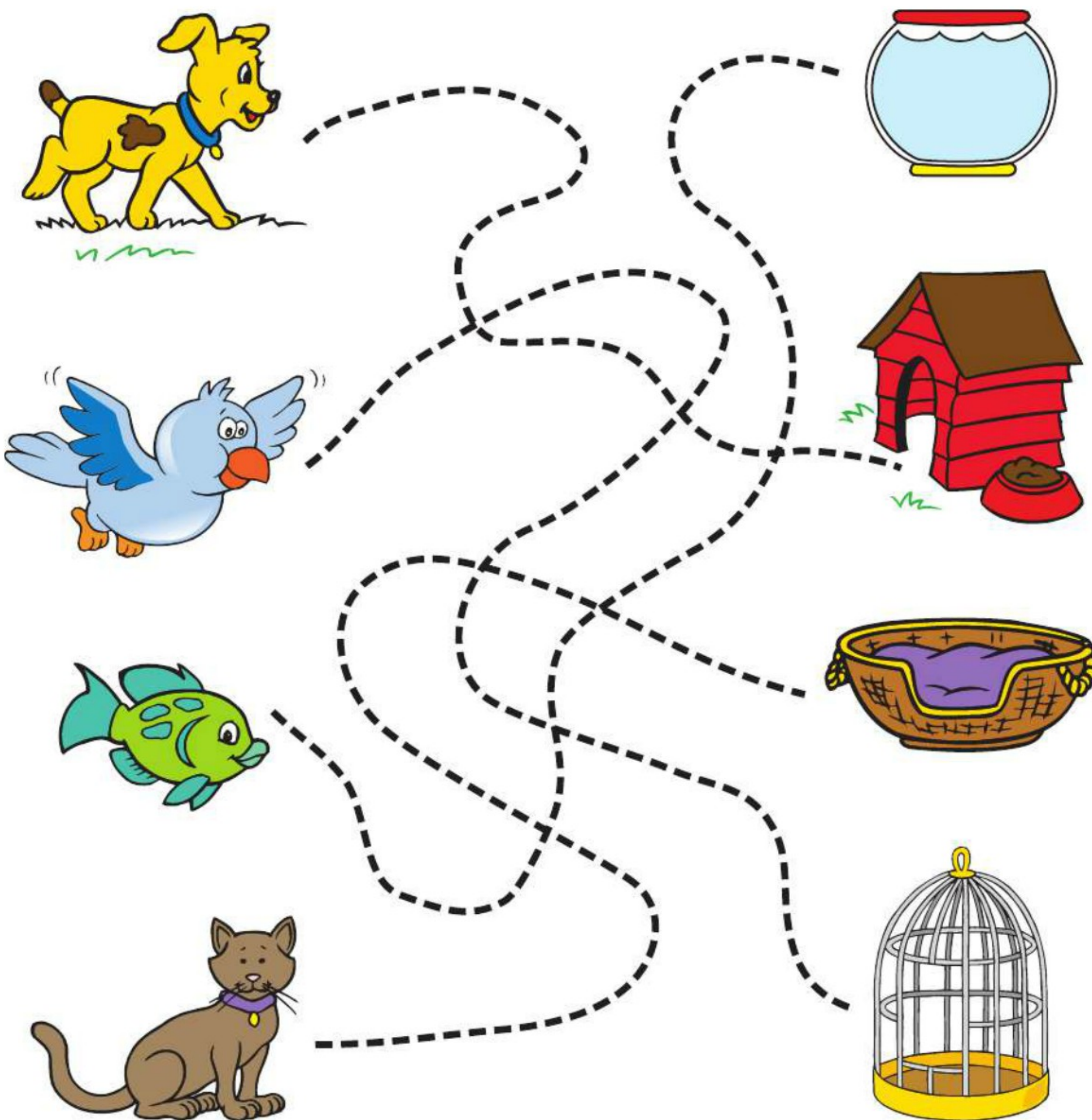



# Follow, Follow

**Directions:** Follow the animals with your finger as they move across the page. Then, **draw**  a line with a pencil or a crayon to trace each path.

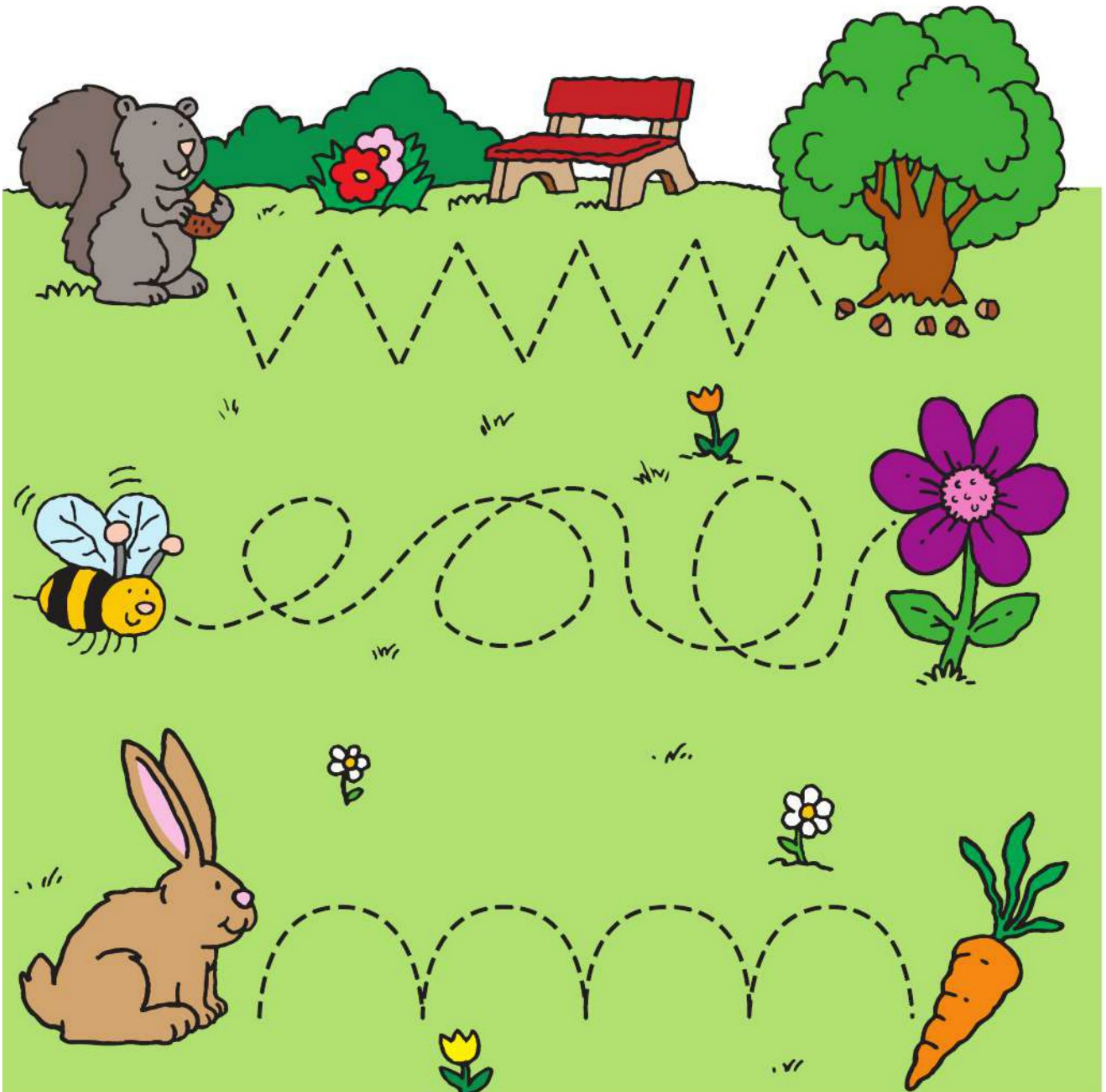



# Where Is My Home?

**Directions:** Draw  a line from each animal to its home.



**Note to Parents:** These activities help with one-to-one correspondence and tracking left to right, which is a pre-reading skill.

Name \_\_\_\_\_

LEFT TO RIGHT



# One to One

**Directions:** Draw  lines to help the ants get back to the picnic baskets!

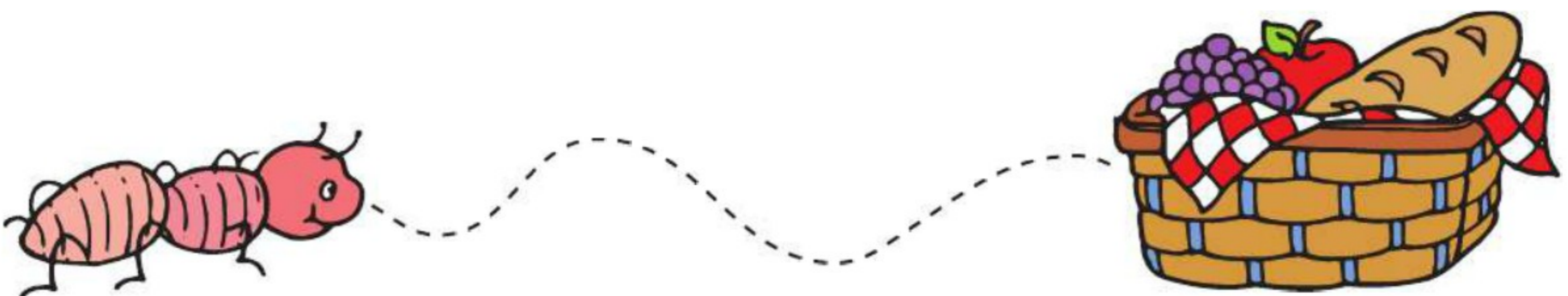
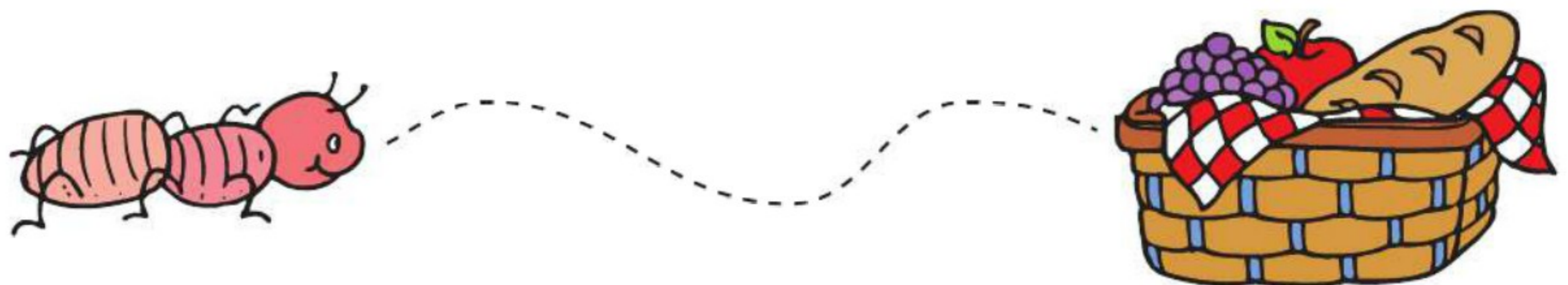
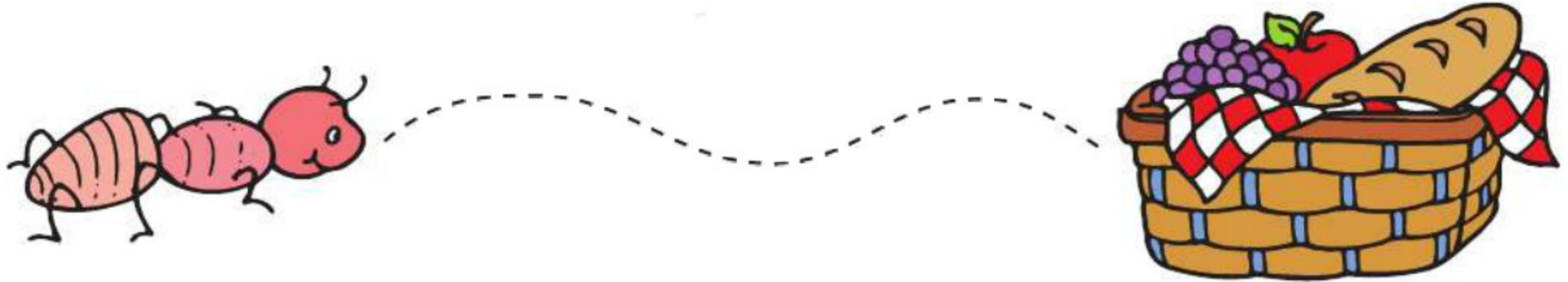



# Let's Play!

**Directions:** Draw  a line from each picture on the **left** to a place to play on the **right**. The first one is done for you.

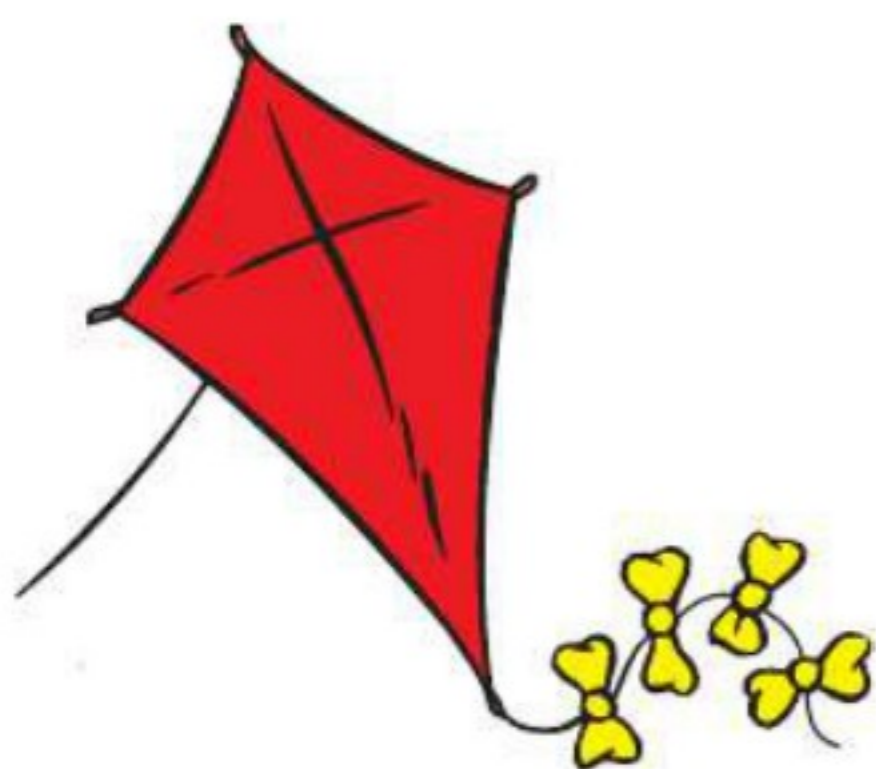
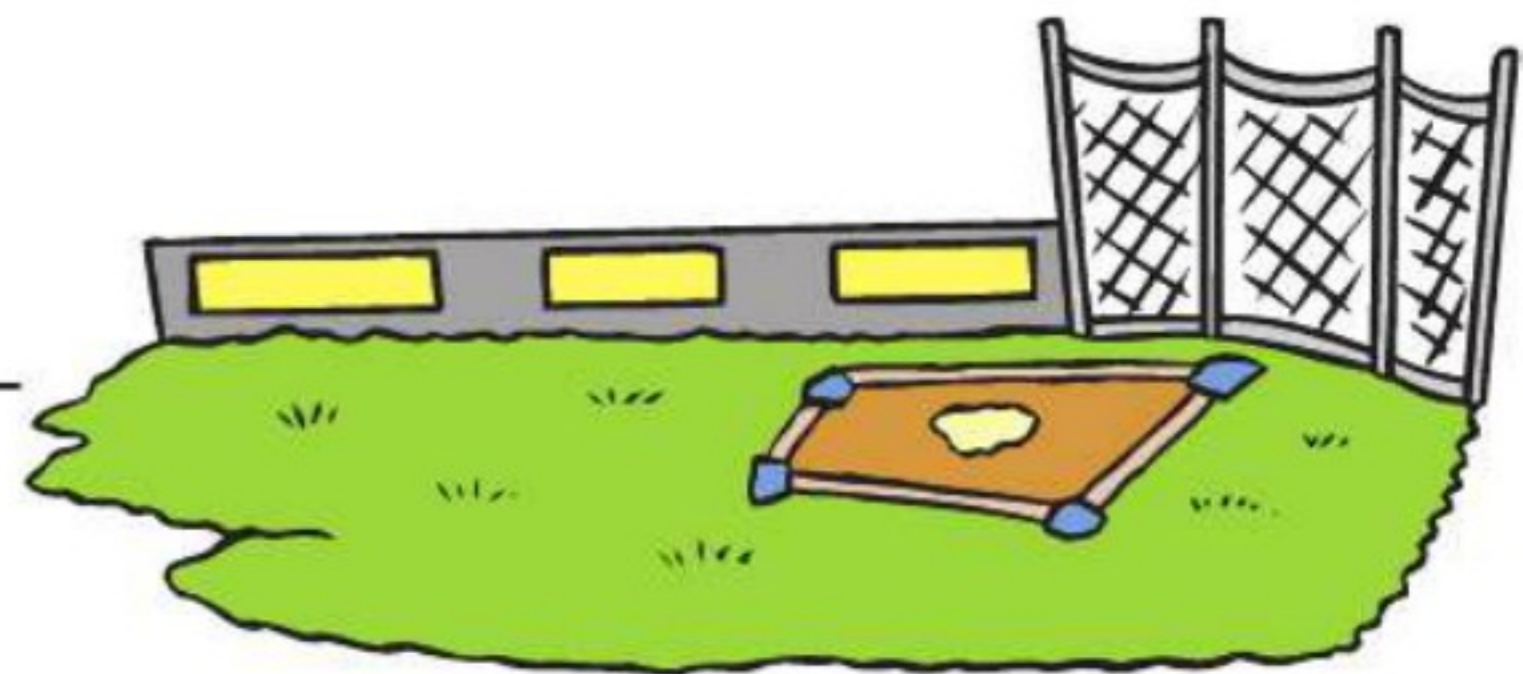

Name \_\_\_\_\_

LEFT TO RIGHT



# Help the Bunnies

**Directions:** Draw  lines to help the bunnies get their carrots!

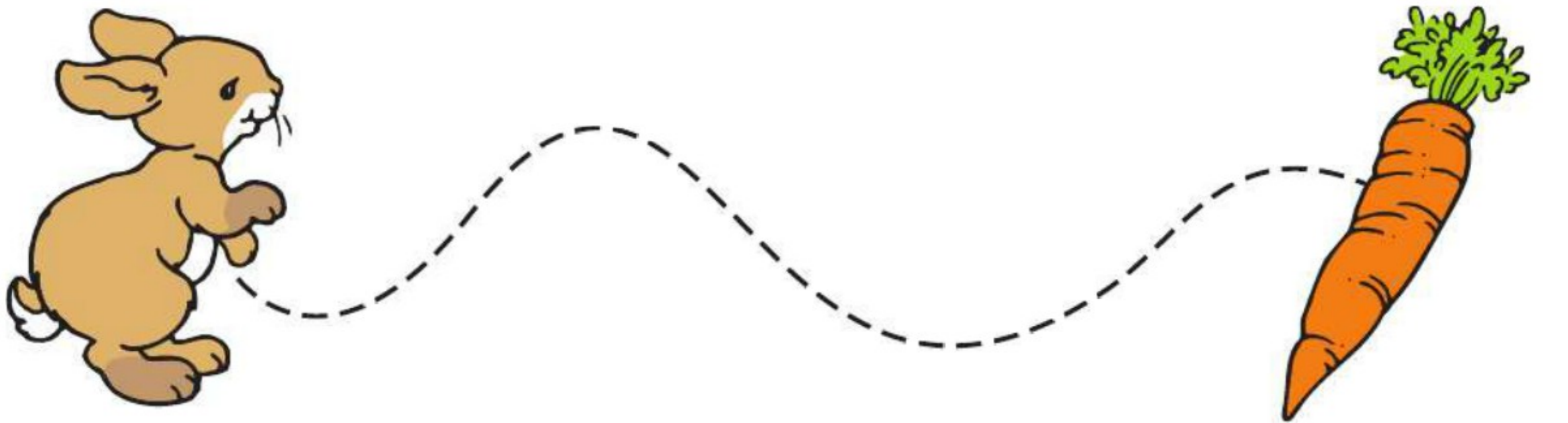
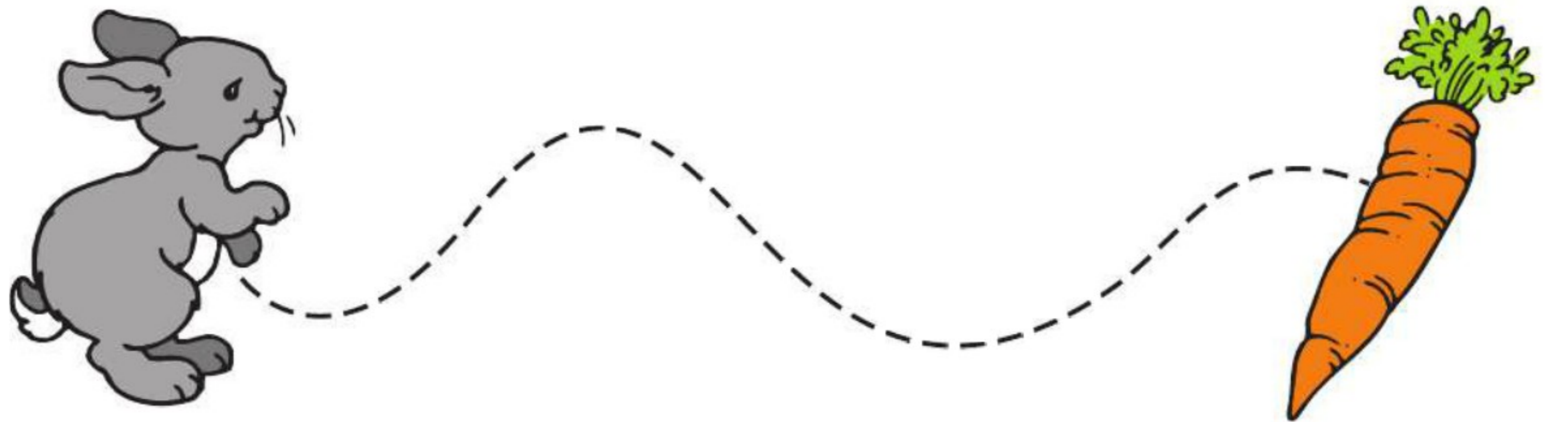
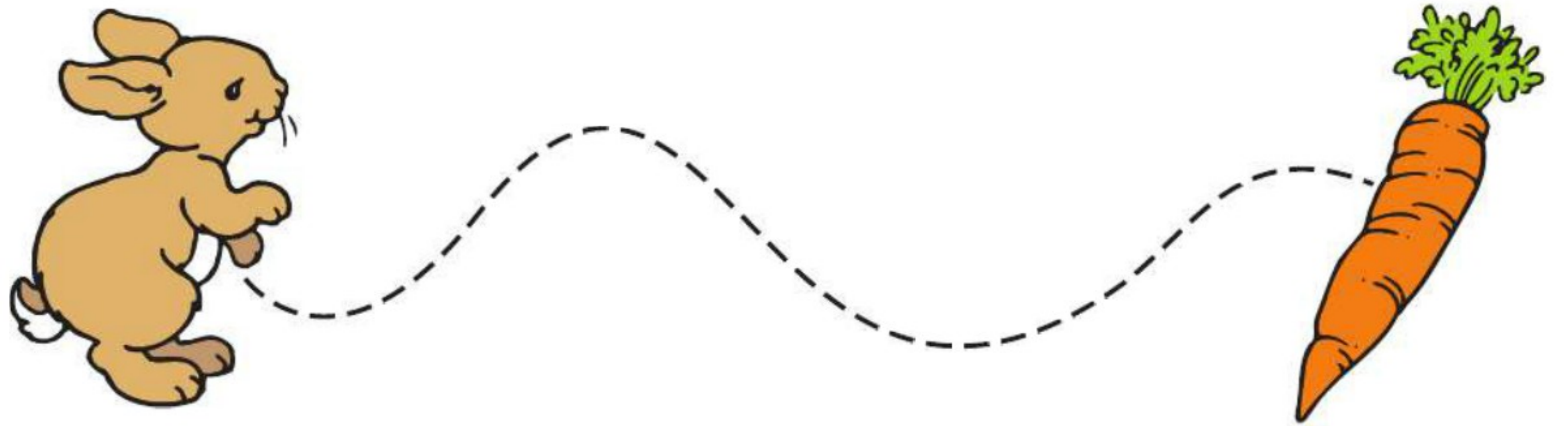
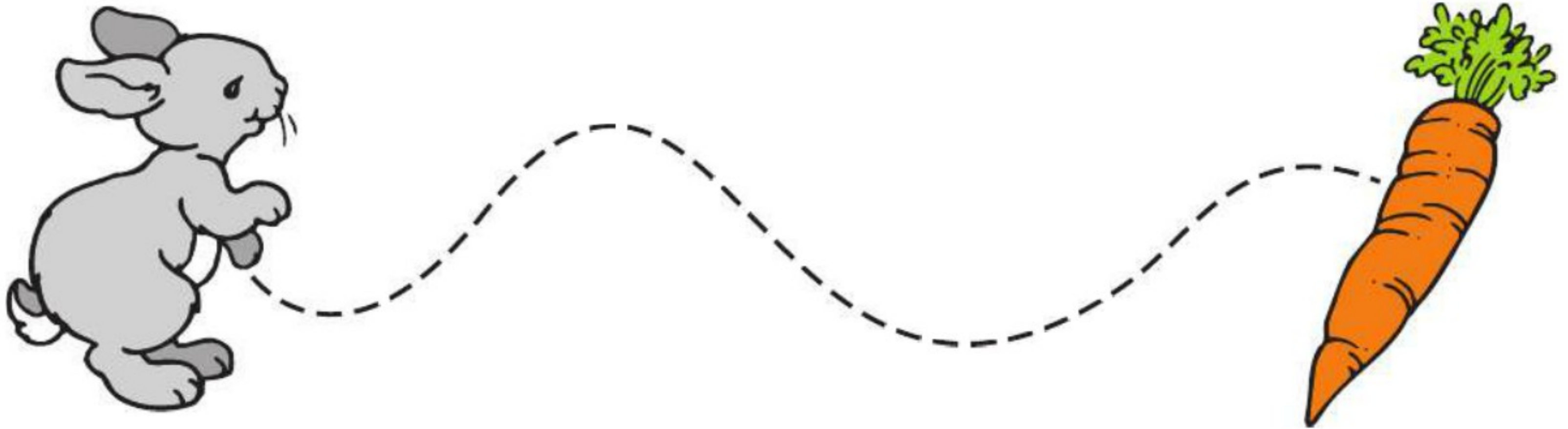



# Matching Tops to Bottoms

**Directions:** Look at the pictures in each box. Starting at the top and going to the bottom, **draw**  a line to match each thing at the top to the thing at the bottom. **Color**  the pictures.

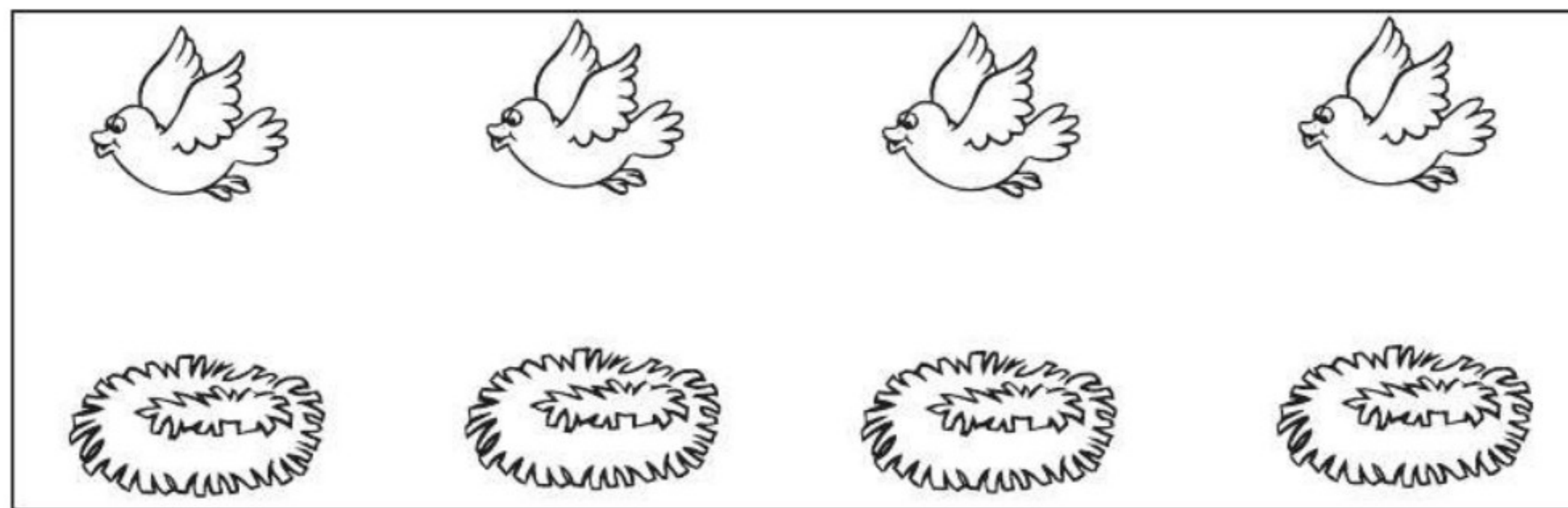
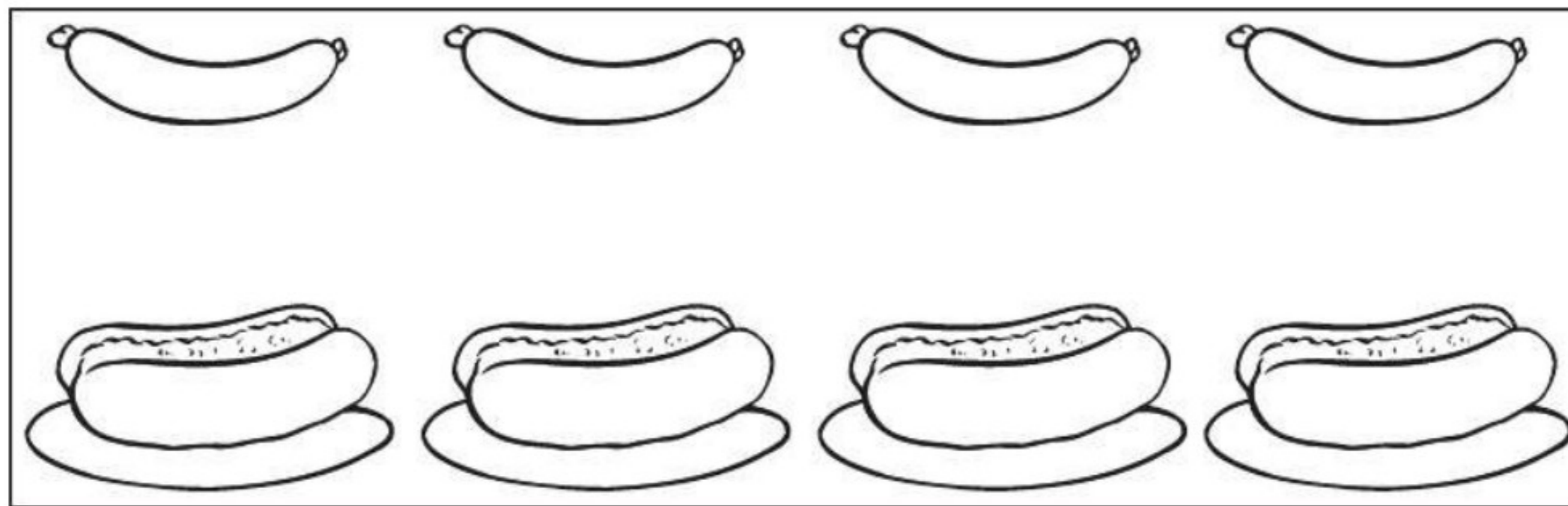
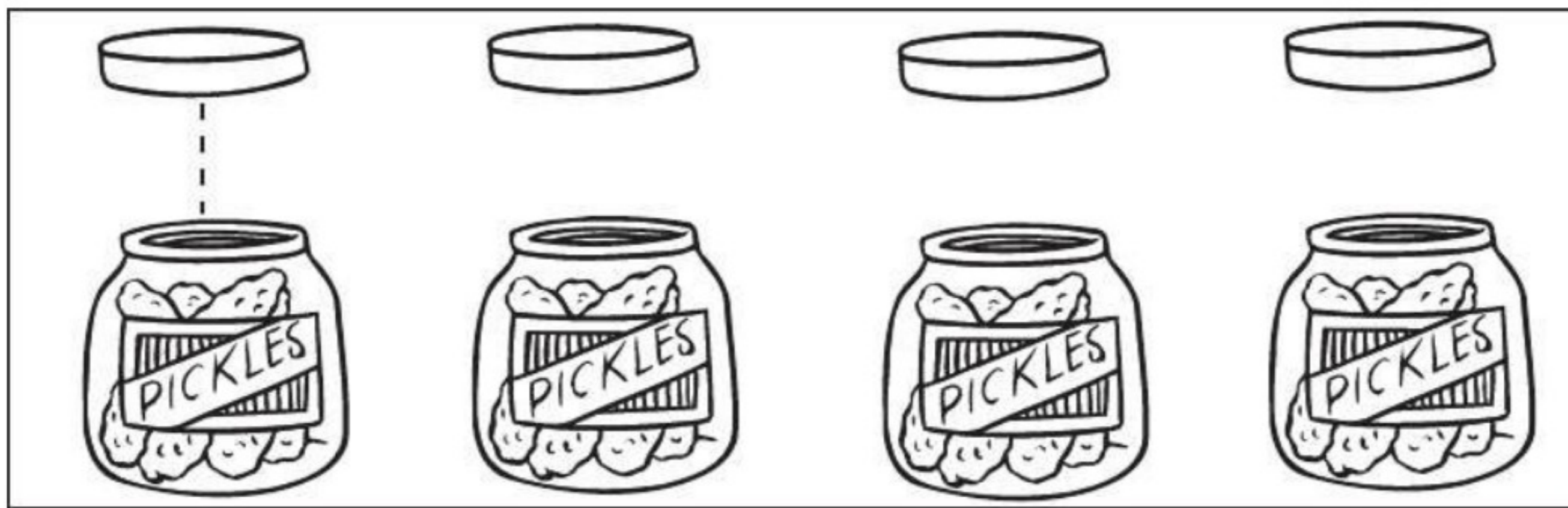

**Note to Parents:** Encouraging your child to start at the top when making vertical lines will help your child develop good handwriting habits for learning to print letters.





# Draw the Caterpillar's Legs

**Directions:** Trace  the lines from top to bottom to make each caterpillar's legs.

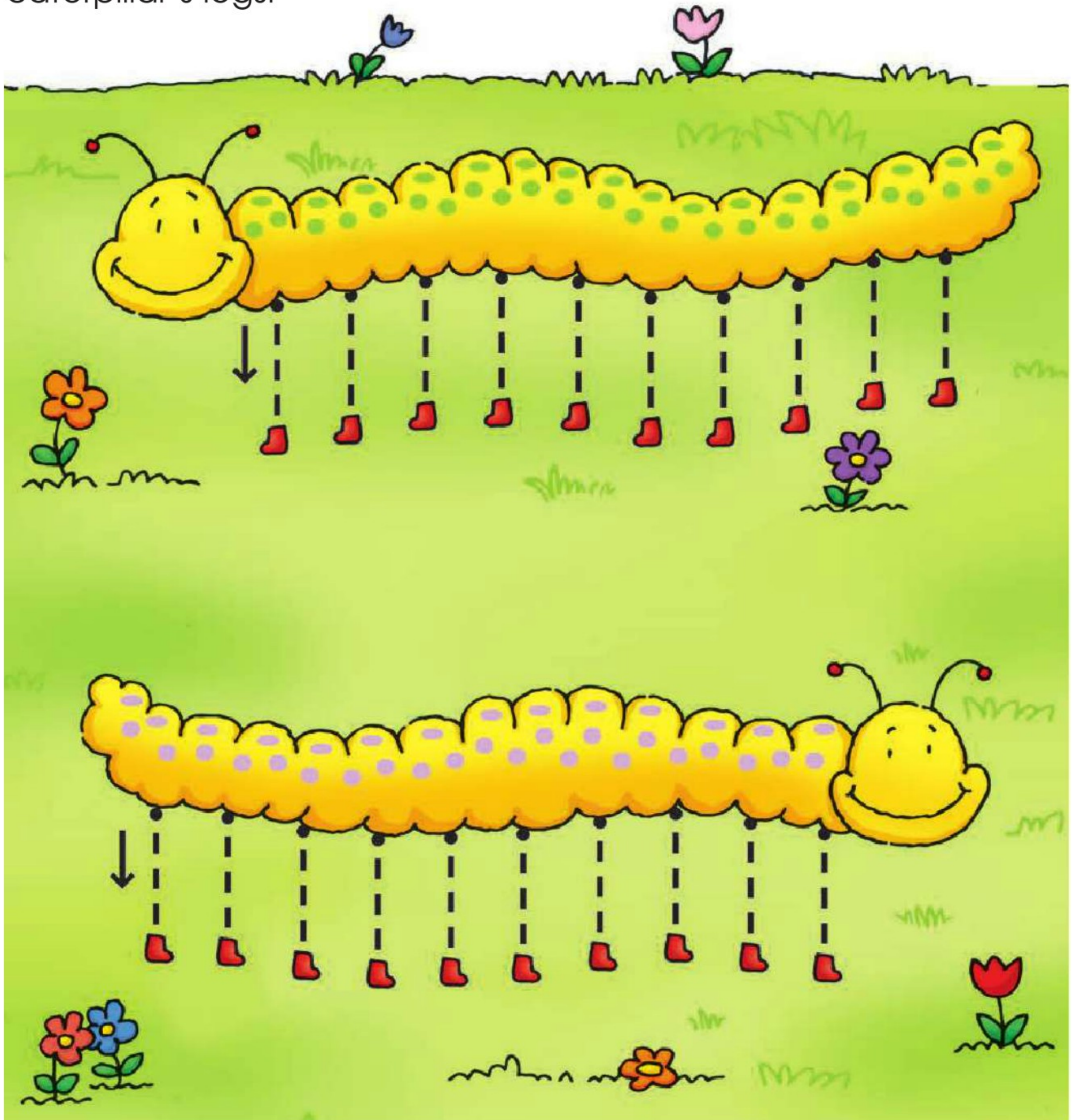



# Hold Onto the Balloons!

Help the children hold onto their balloons.

**Directions:** Trace  the balloon strings from top to bottom.

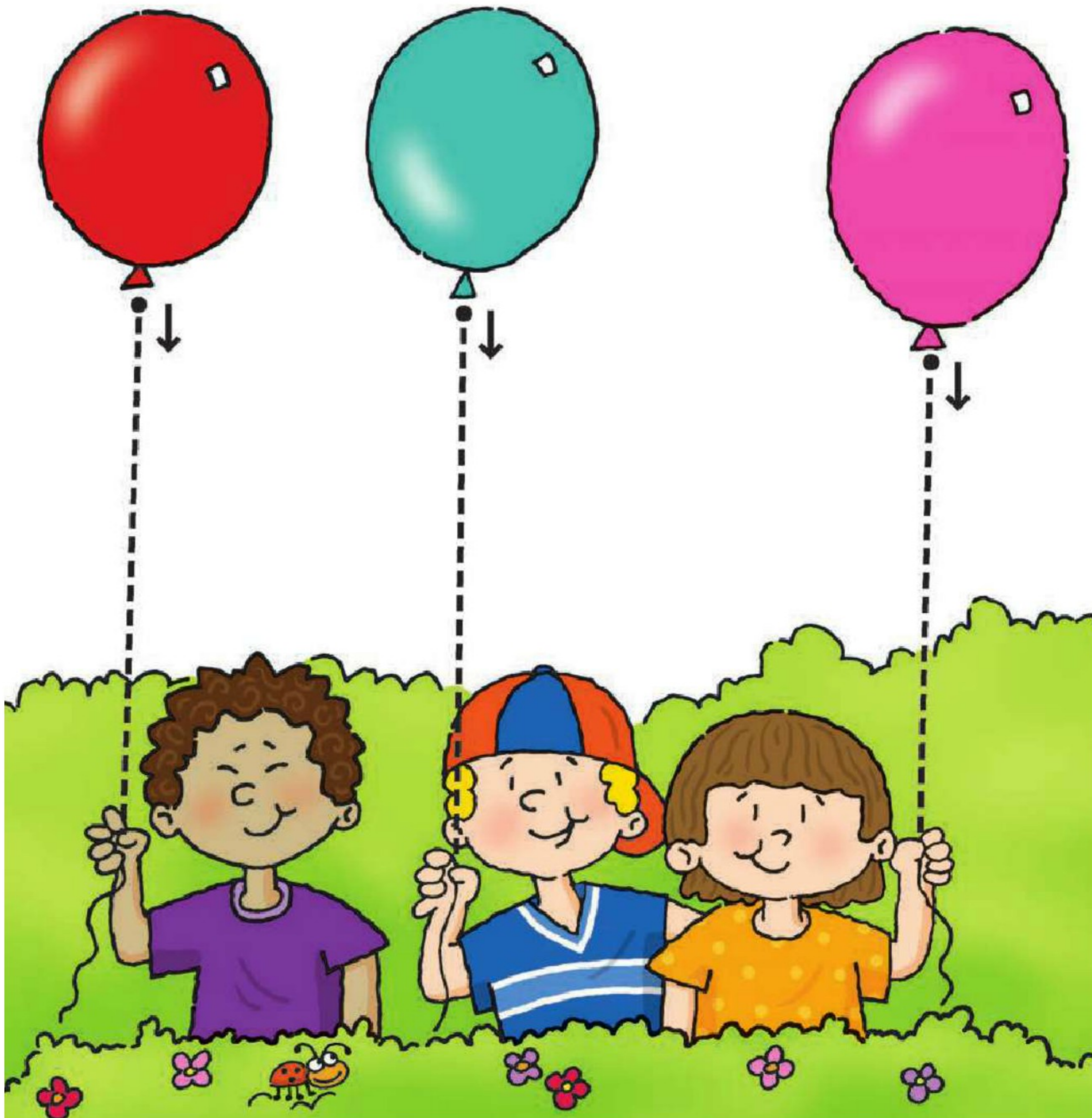



# Spinning Webs

Help the spiders make their web.

**Directions:** Trace  the lines from top to bottom.

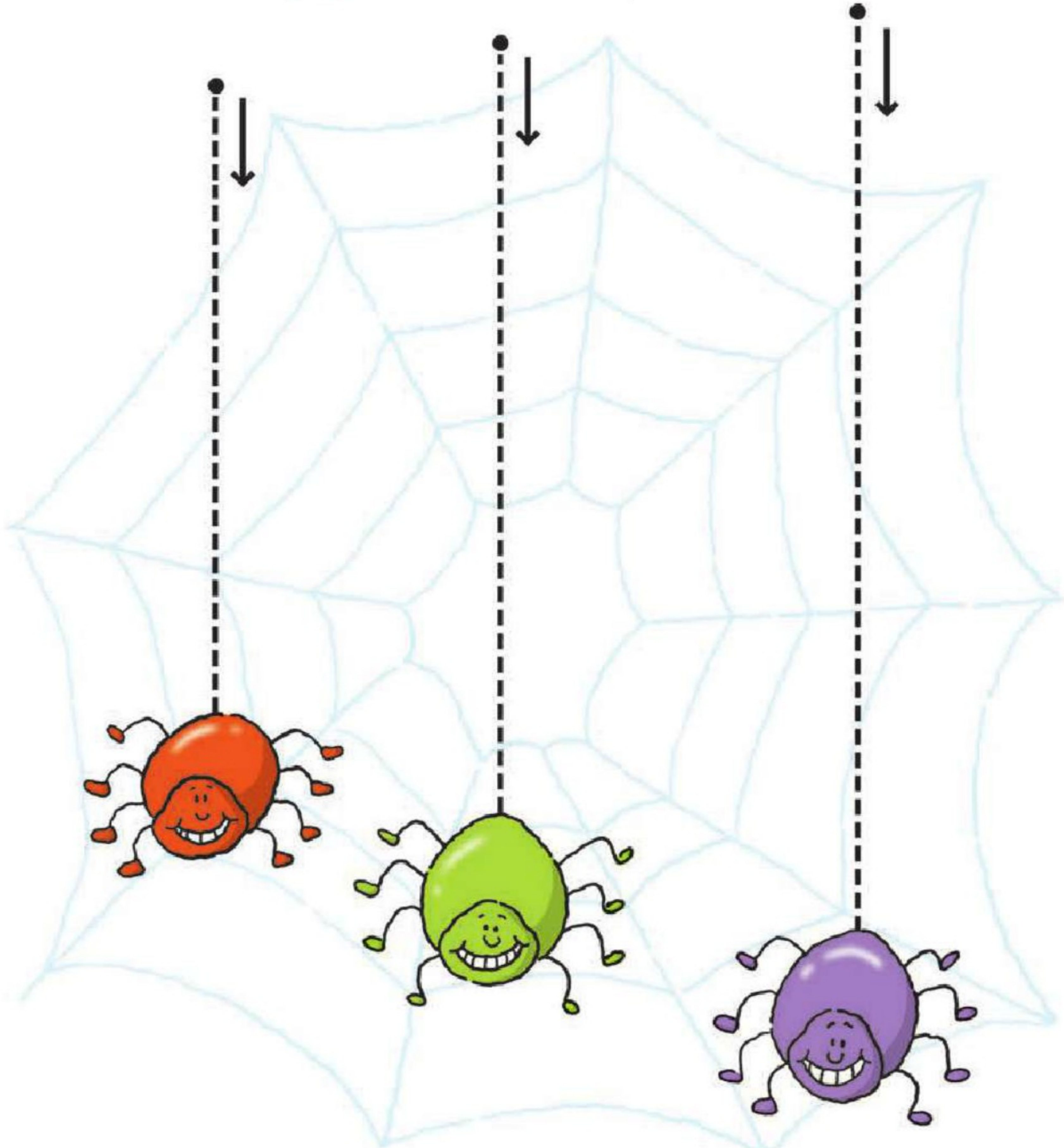



# Flower Stems

**Directions:** Trace  the lines from top to bottom to make stems on the flowers.

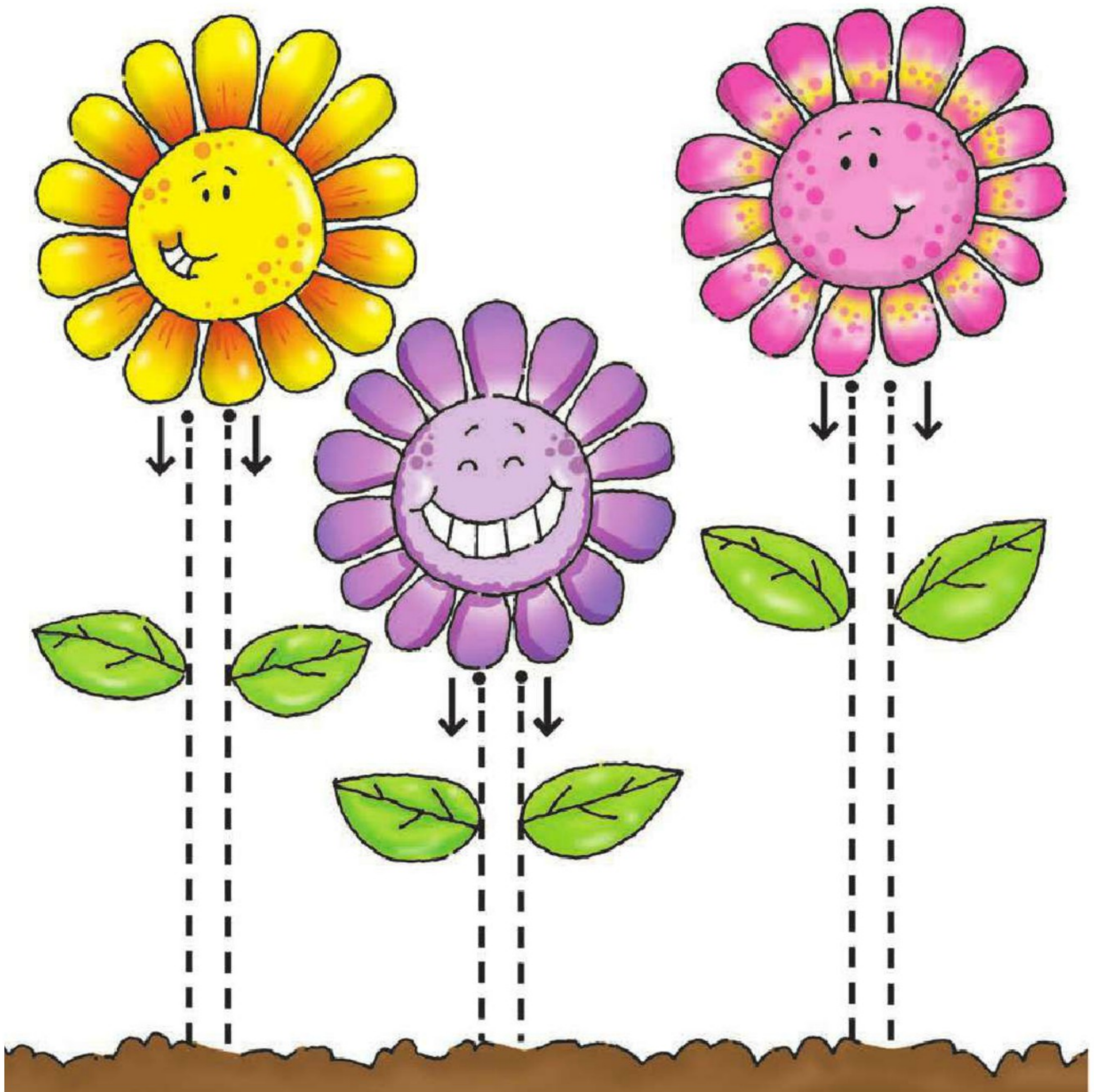



# Fire!

Help the firefighters get to the fire.

**Directions:** Trace  the lines from top to bottom.

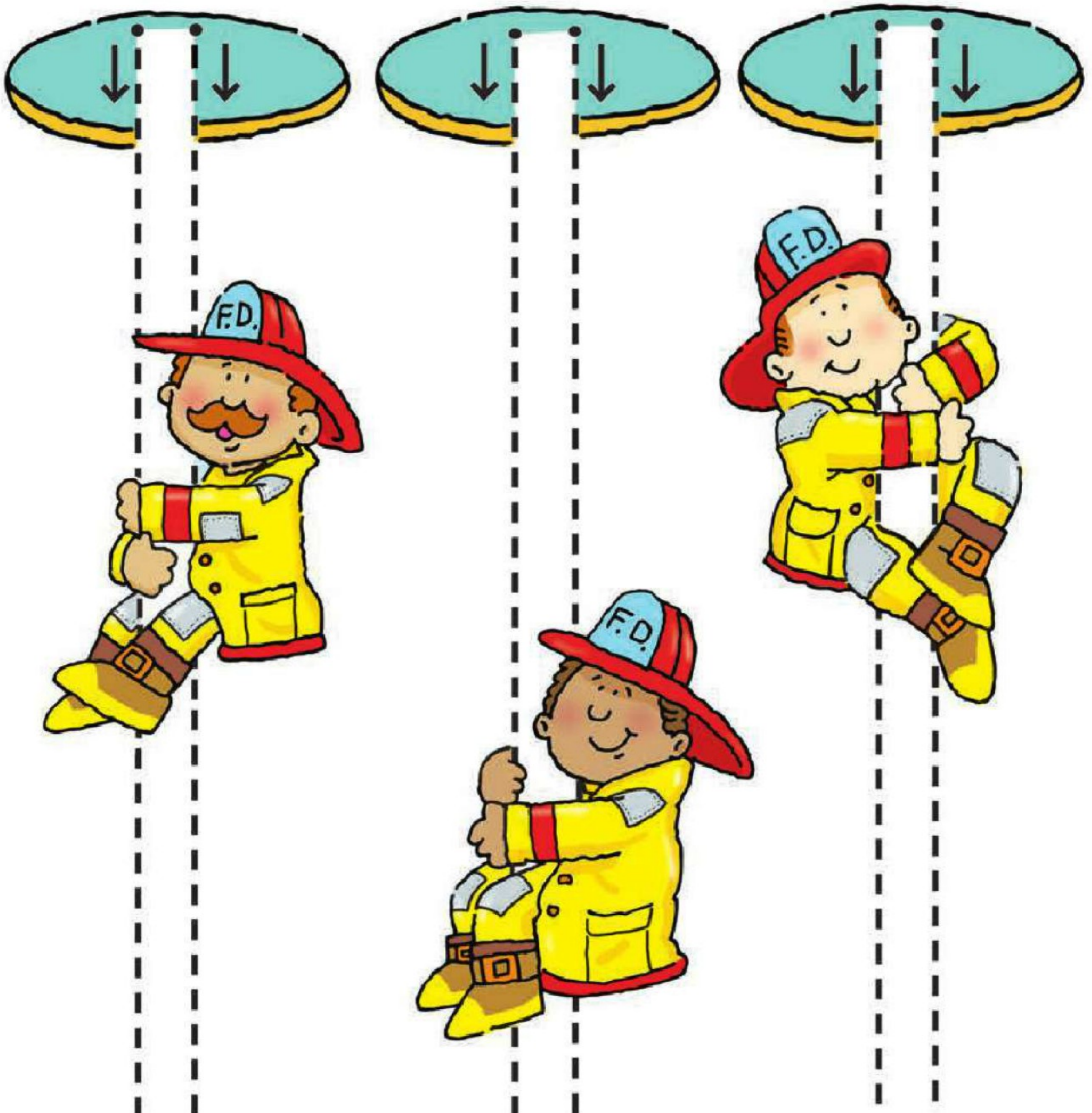



# Sliding Down the Hill

Help the children slide down the hill.

**Directions:** Trace  the lines from top to bottom.

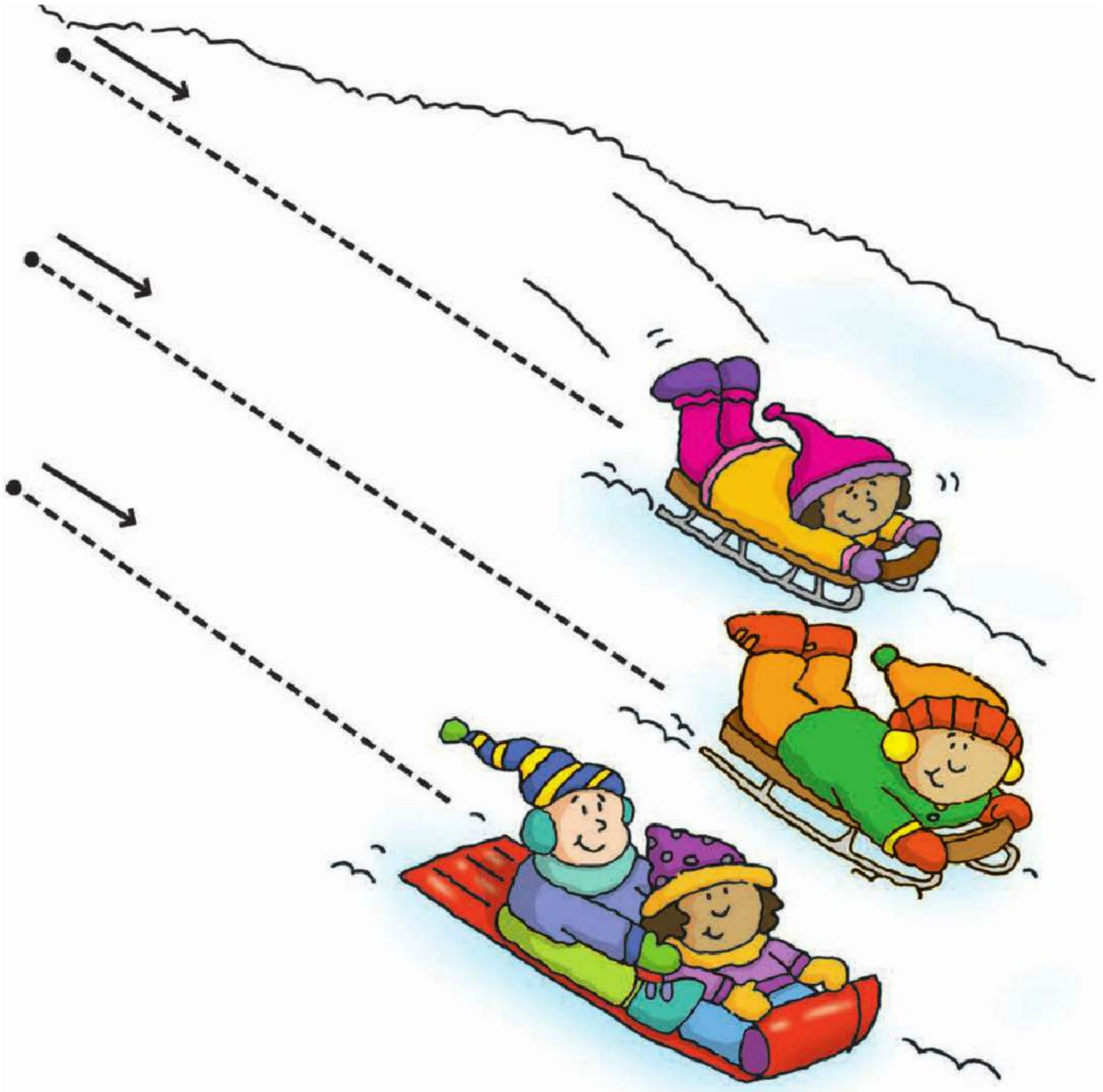



# Slanted Lines

**Directions:** Start at the top dots. **Trace**  the dotted lines.

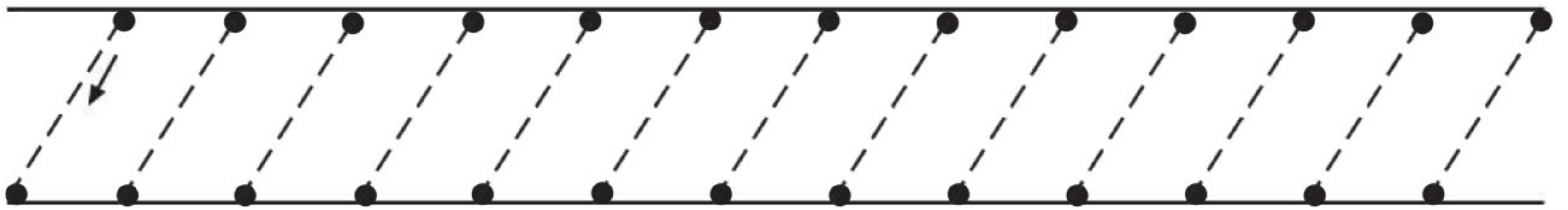
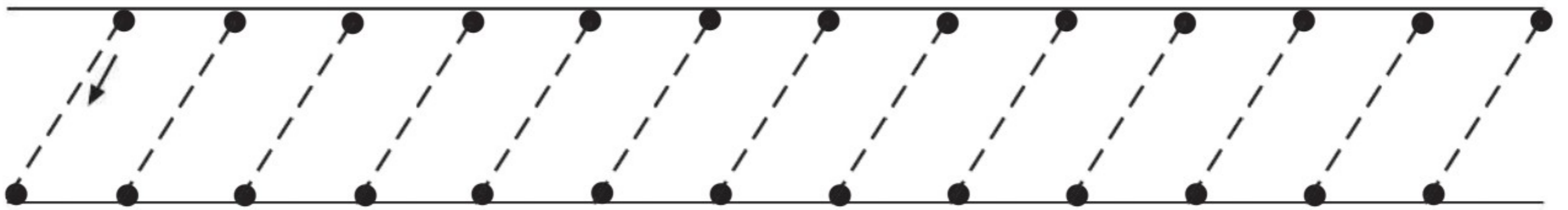
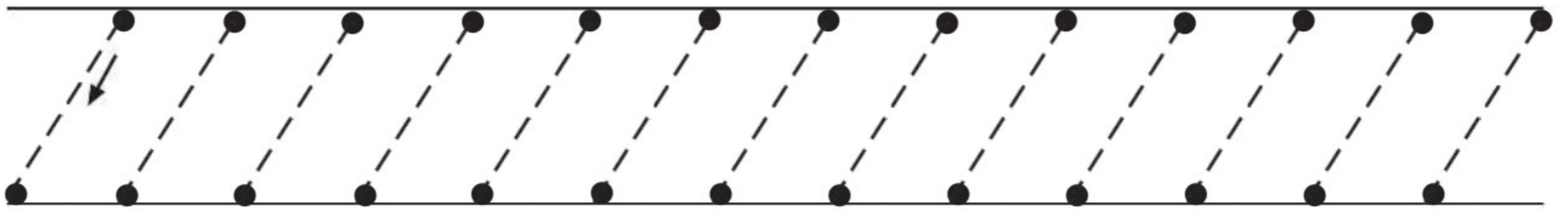
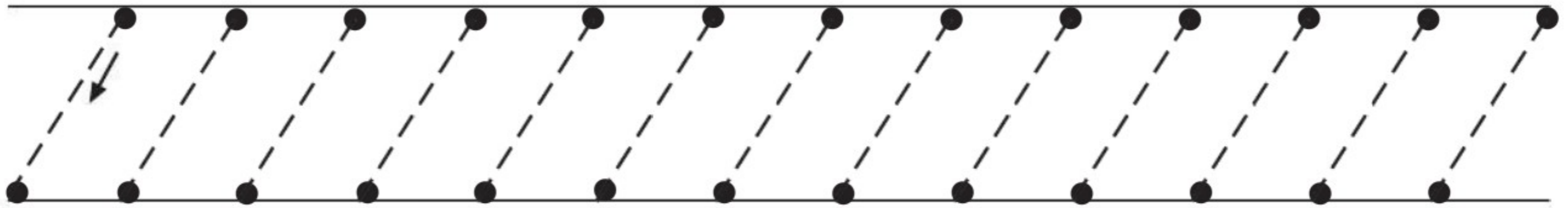



# Curved Lines

**Directions:** Trace  each ball's bounces from left to right.

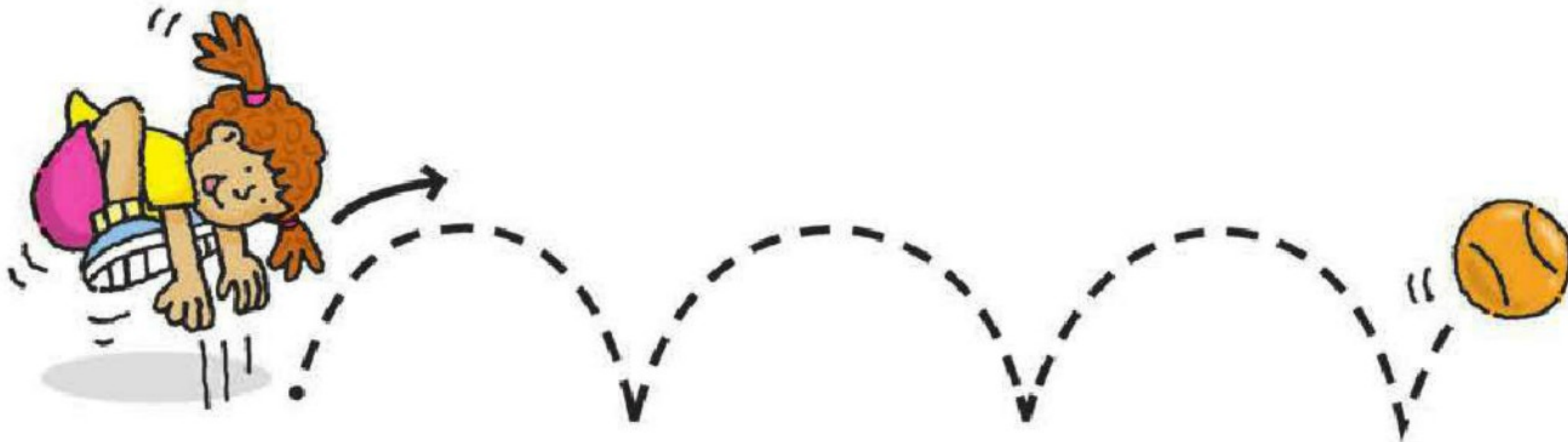
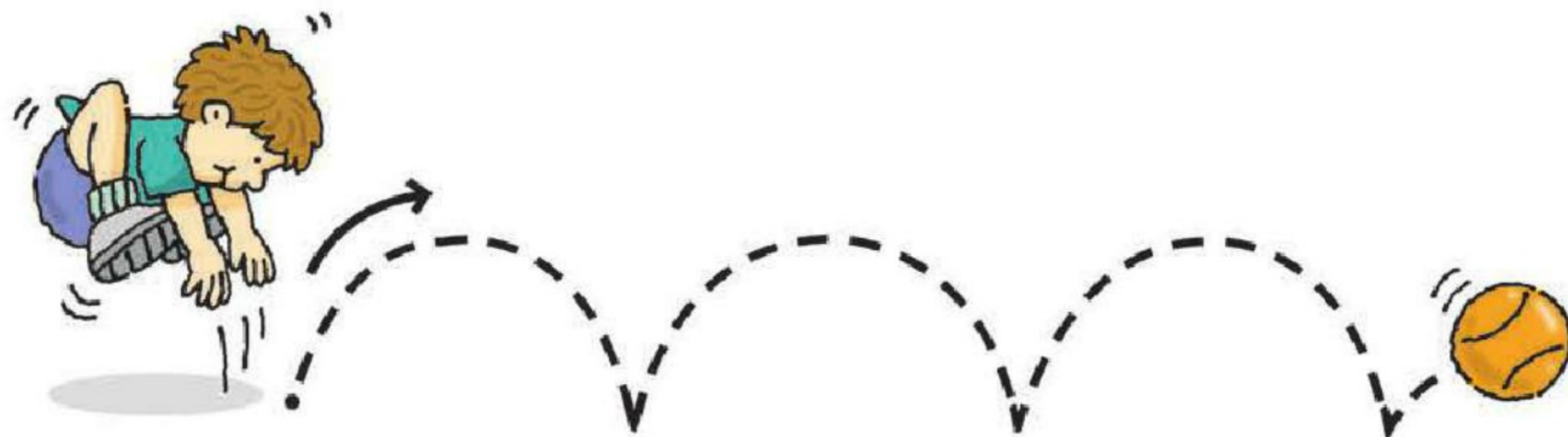

Now, draw this ball's bounces on your own.







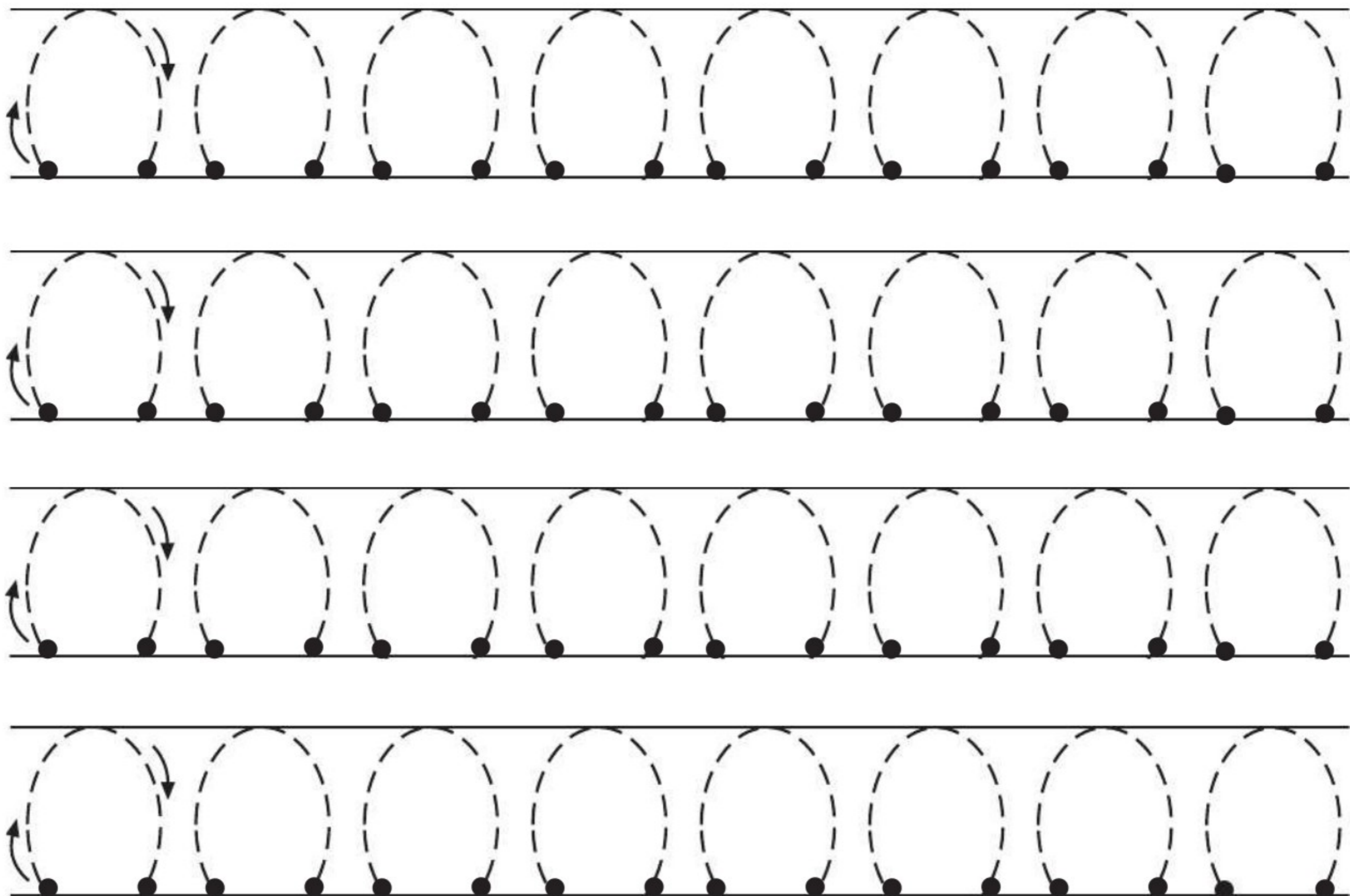

# More Curved Lines

**Directions:** Start at the dots. **Trace**  the dotted lines.





## Forward Circles

**Directions:** Follow the arrows to **trace**  the circles on each ice-cream cone.

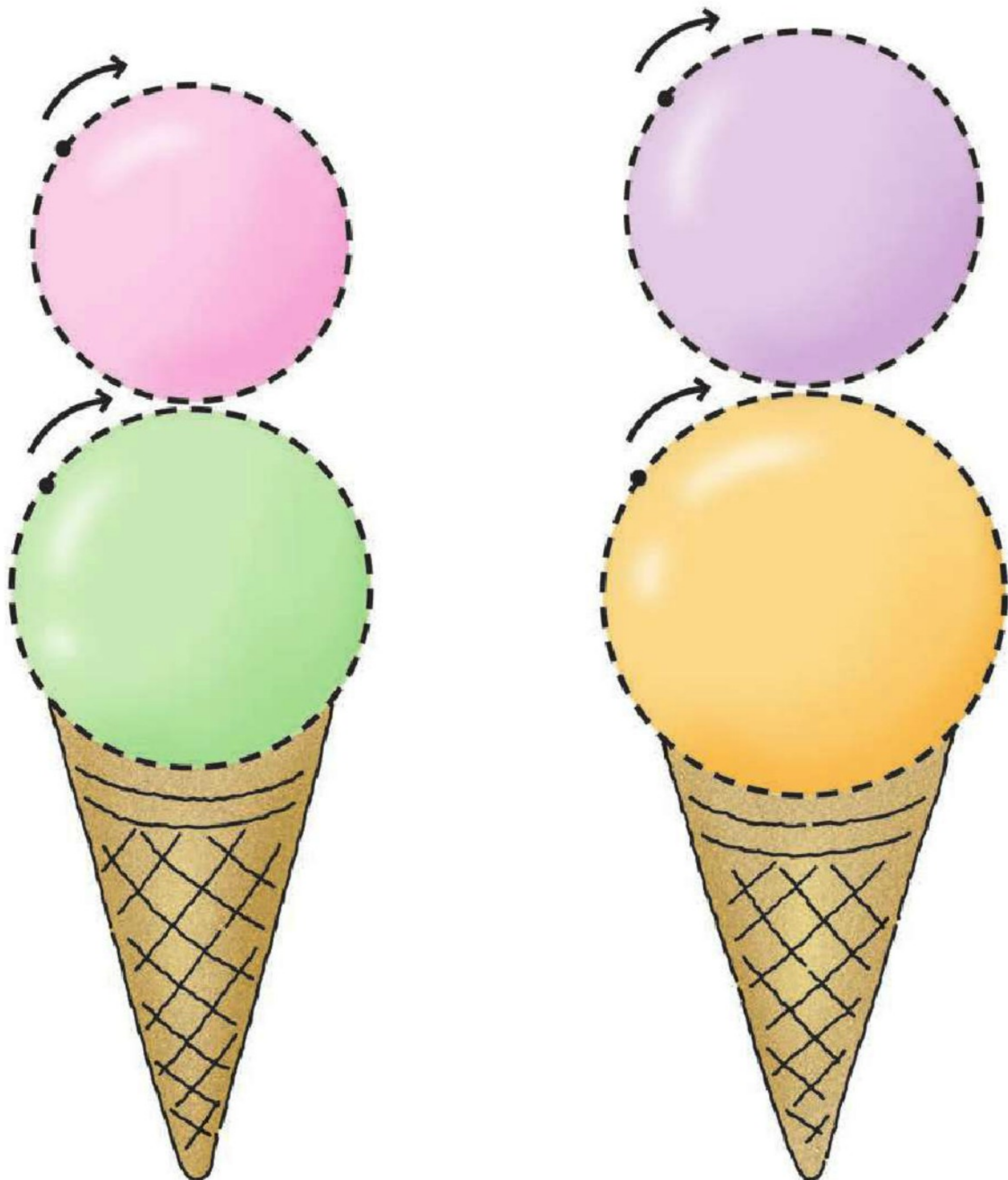



## More Forward Circles

**Directions:** Follow the arrows to **trace**  each circle on the sun and the flowers.

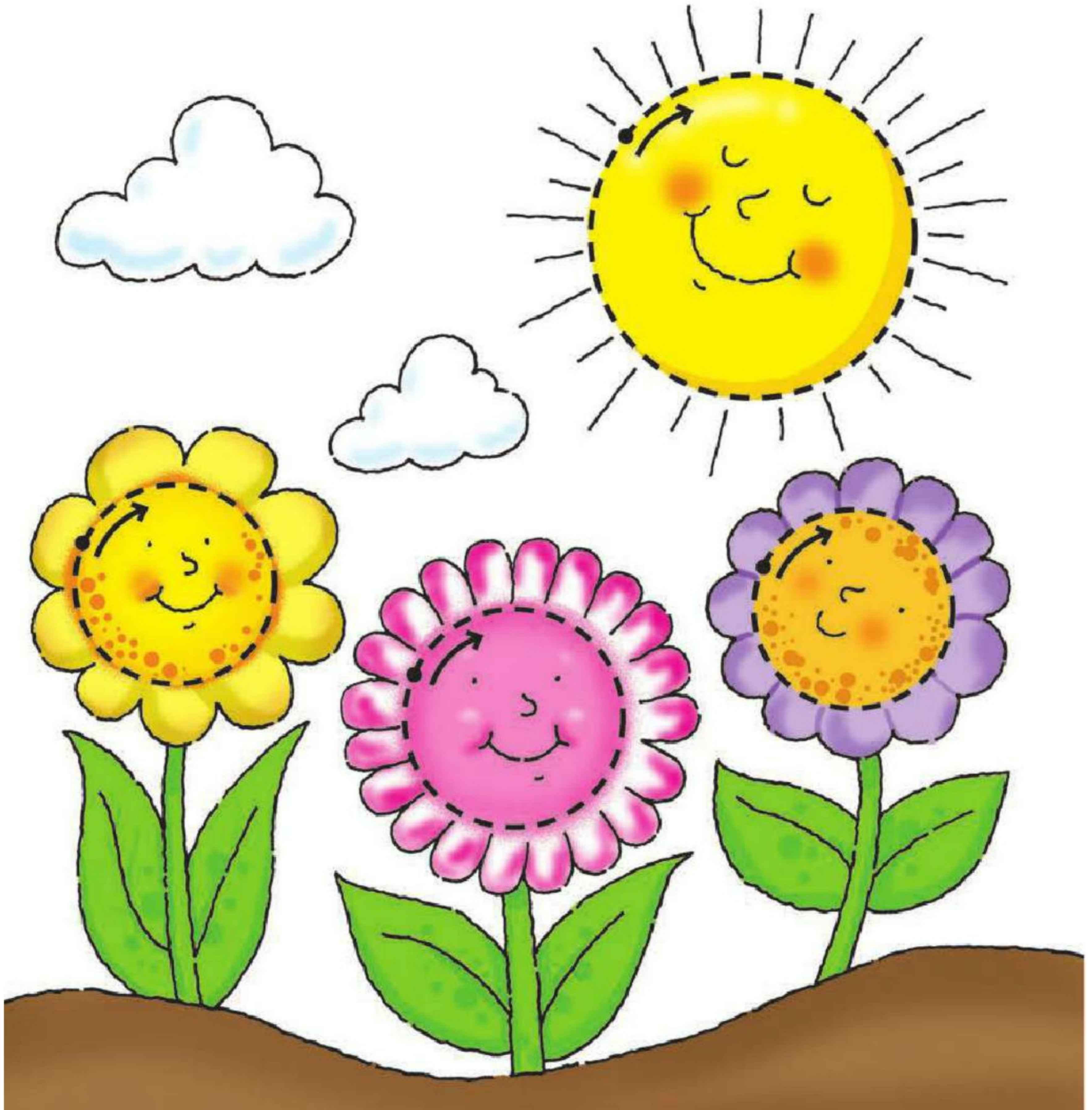



# Backward Circles

**Directions:** Start at the dots. **Trace**  the dotted lines.

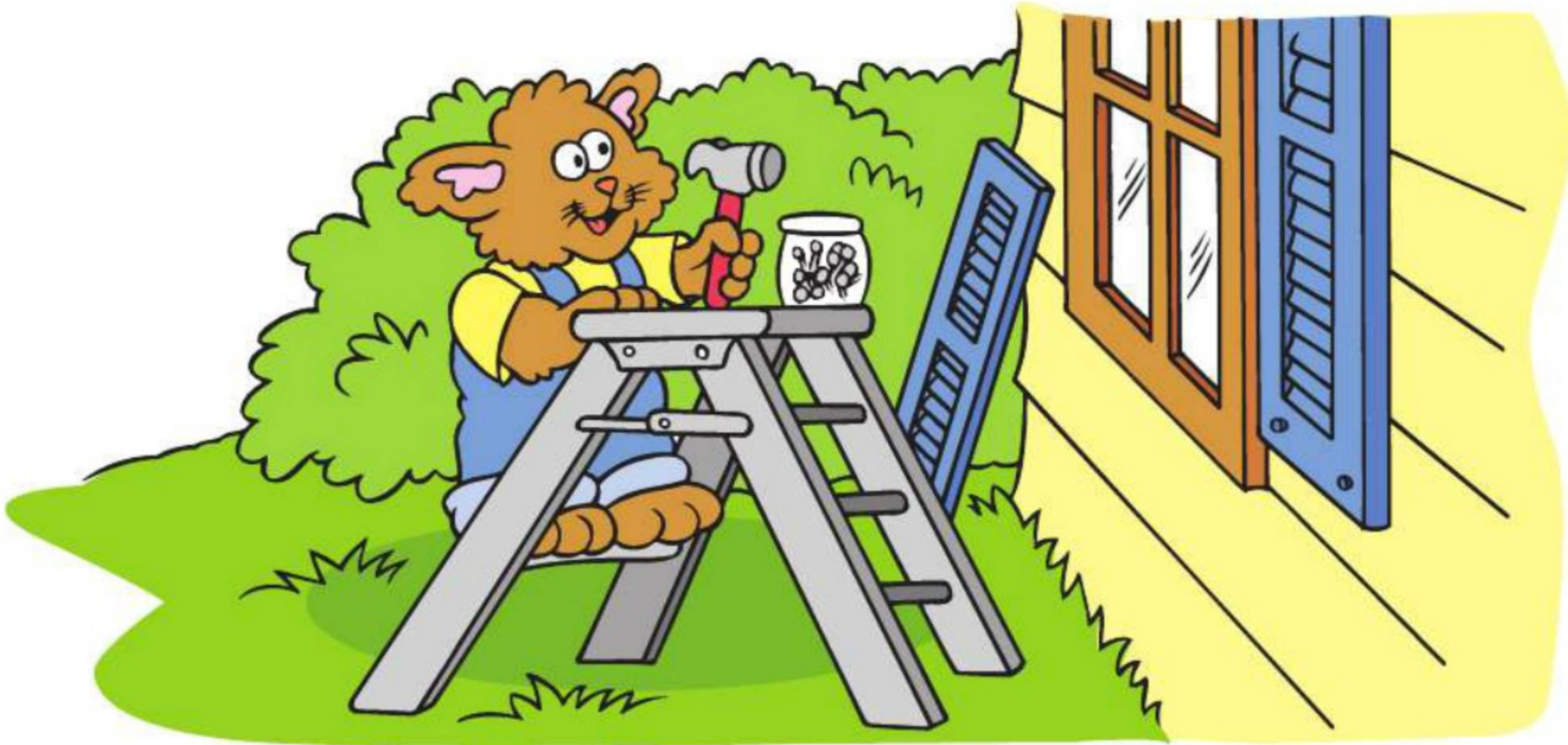

Tracing practice area consisting of four rows of circles. Each row contains seven circles. The first circle in each row is a dashed line with a solid dot at the top and arrows indicating a counter-clockwise direction. The remaining six circles in each row are dashed lines with a solid dot at the top, intended for tracing.



## More Backward Circles

**Directions:** Follow the arrows to **trace**  each circle on the lollipops.

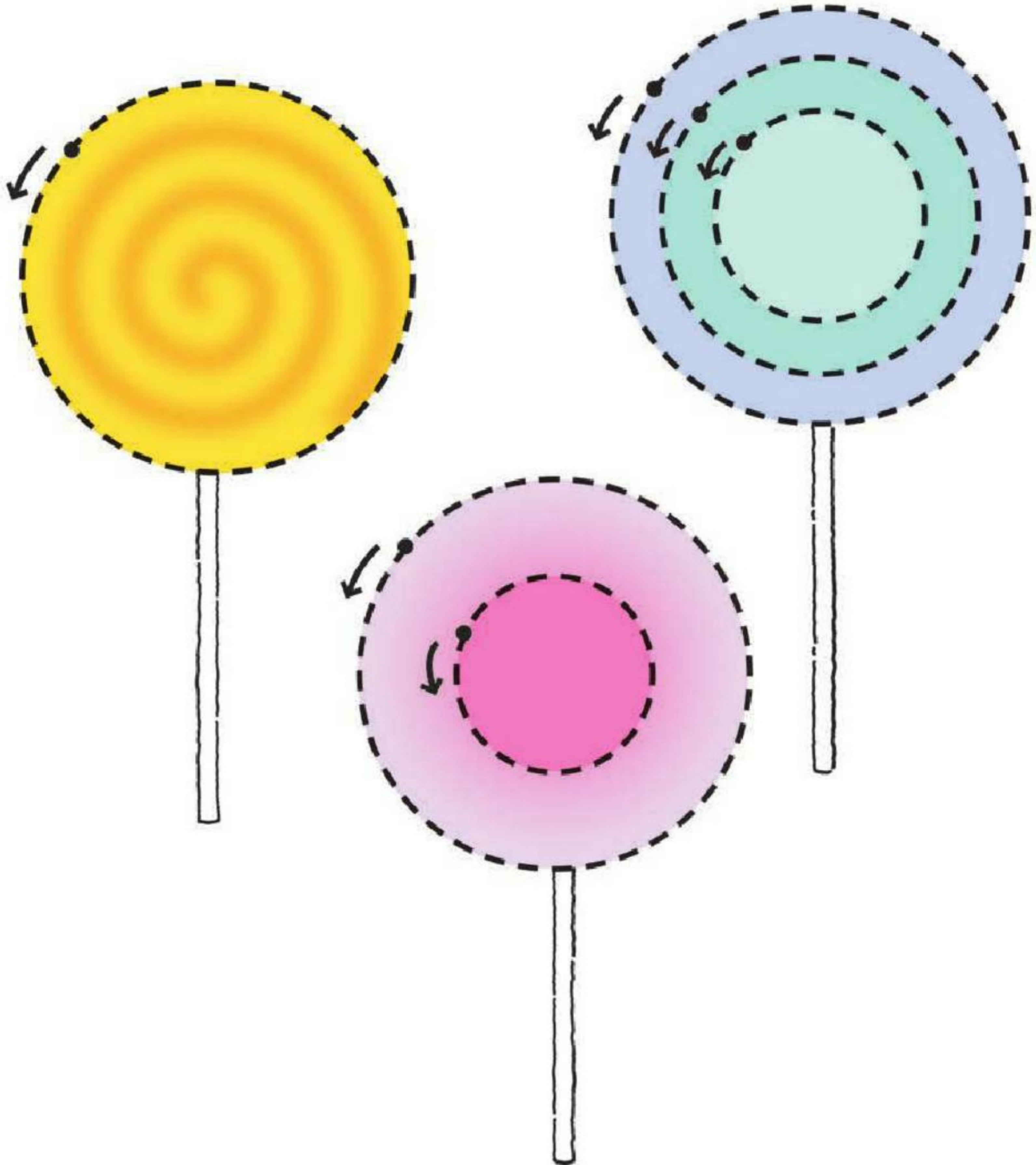



# Letter Aa

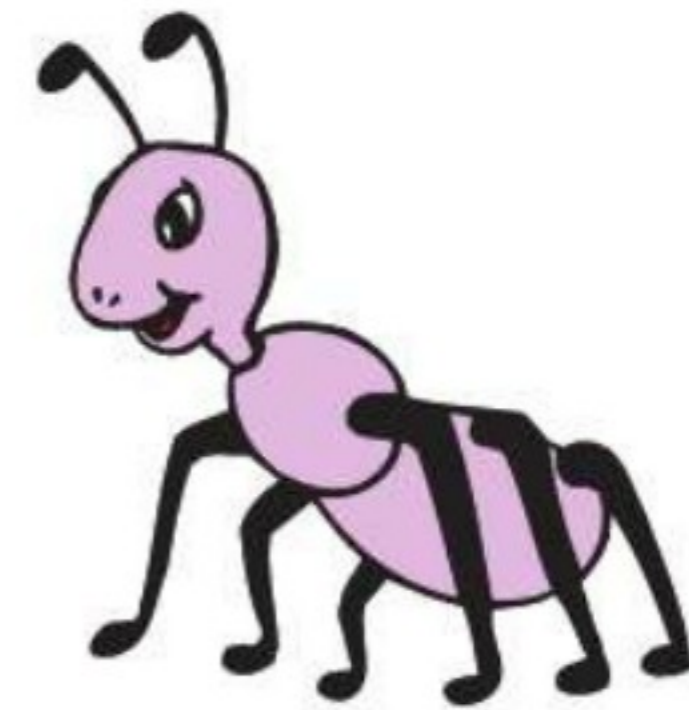

**Directions:** Trace and write  the letter Aa.

UPPERCASE

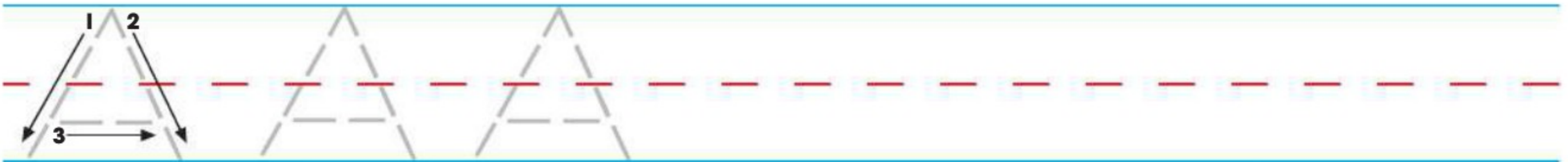

lowercase



**Directions:** These pictures begin with the letter Aa.

**Color**  the pictures.

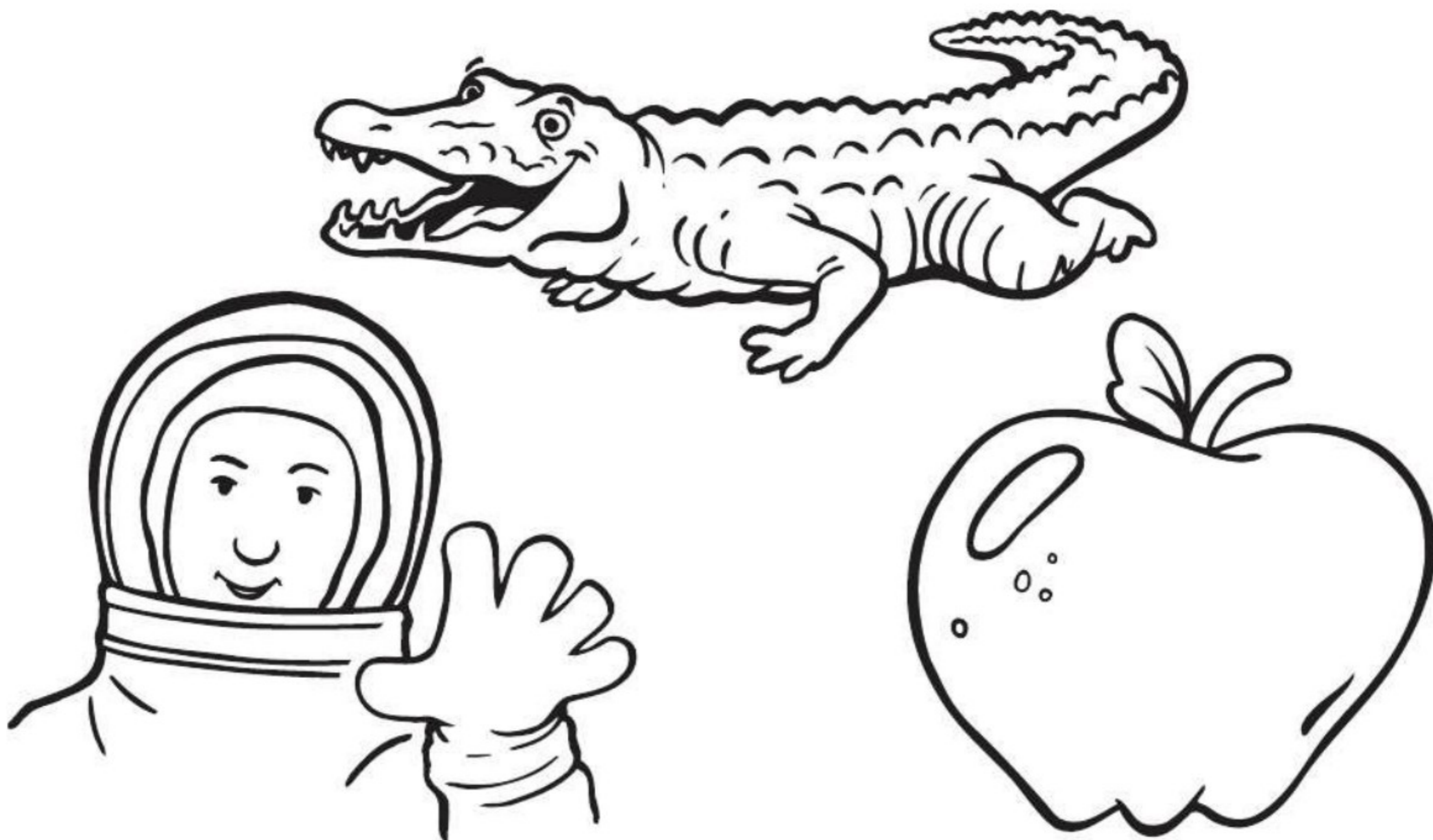



# Letter Aa

You can help the  find the .

**Directions:** Draw  a line to follow the letters **A** and **a**.

**Color**  the picture.

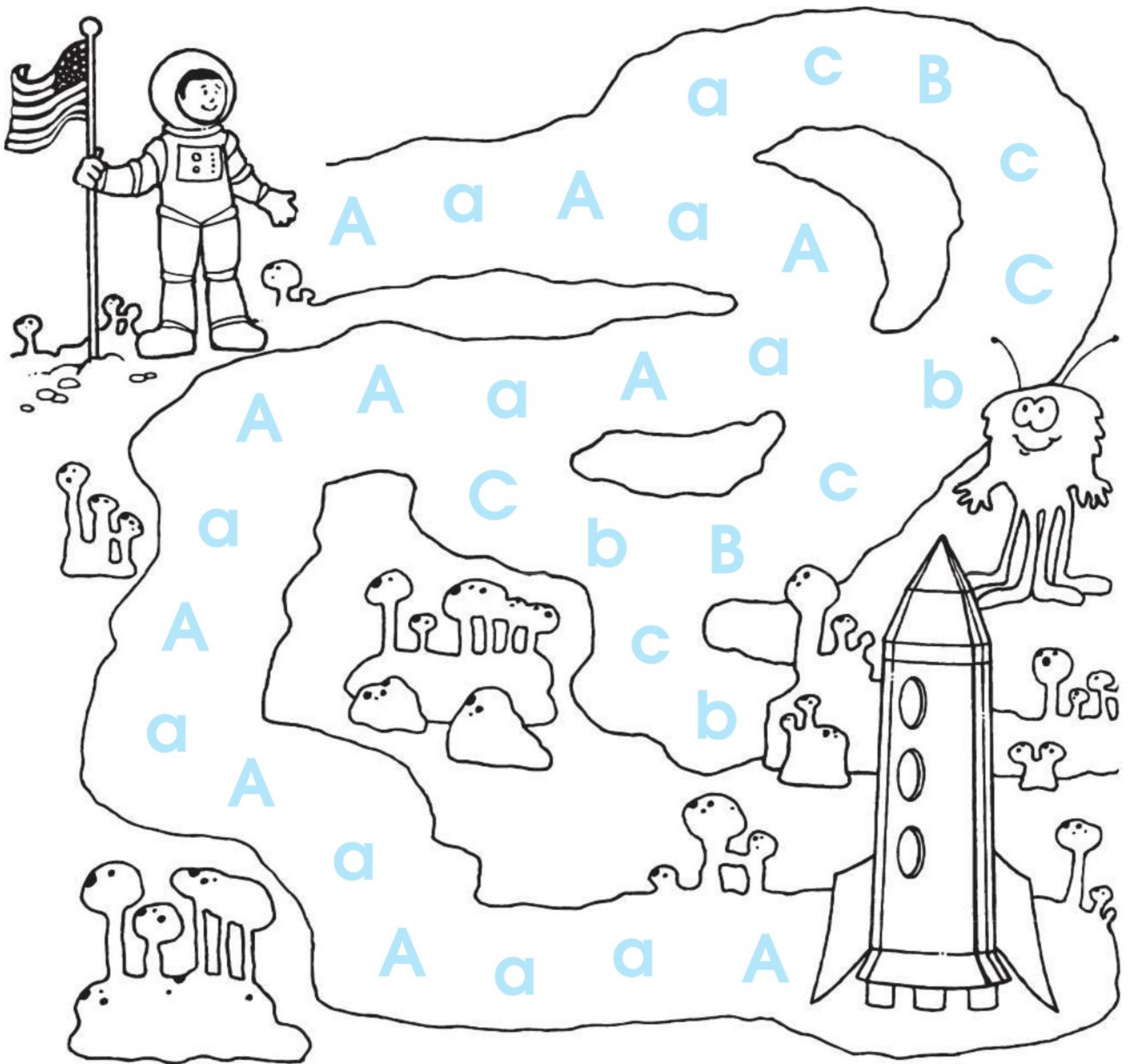



# Letter Aa

**Directions:** Circle  the **A** or **a** in these words:

apple

alligator

angel

Amy

art

Andy

The letter **Aa** can have more than one sound.

**Directions:** Color  the pictures that start with the sound of **Aa**.

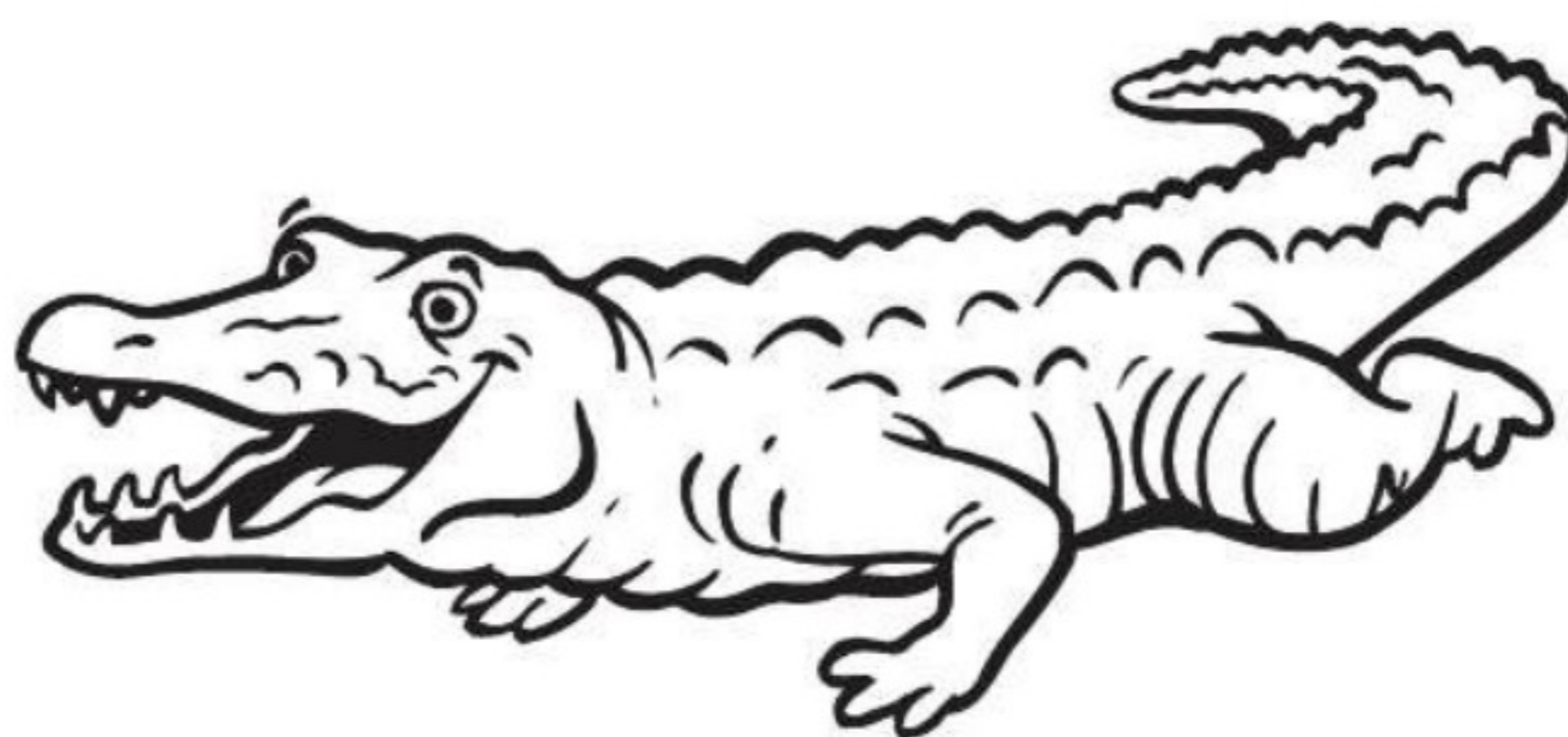





# Letter Aa

These words start with **A** or **a**.

**Directions:** Write  a lowercase **a** on each line.

**Color**  the pictures.

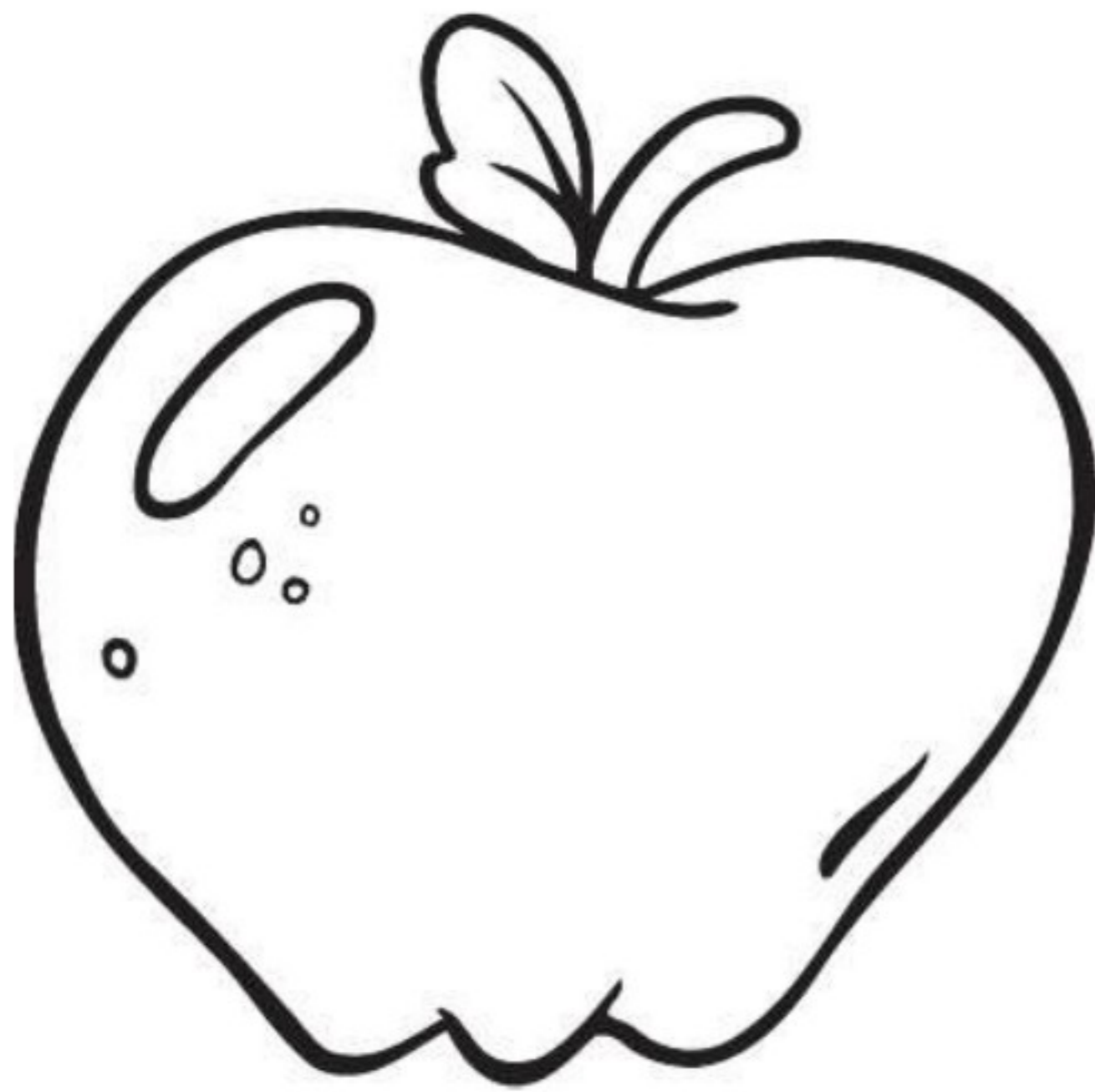

A is for  pple.

A is for  ngel.



A is for  nt.

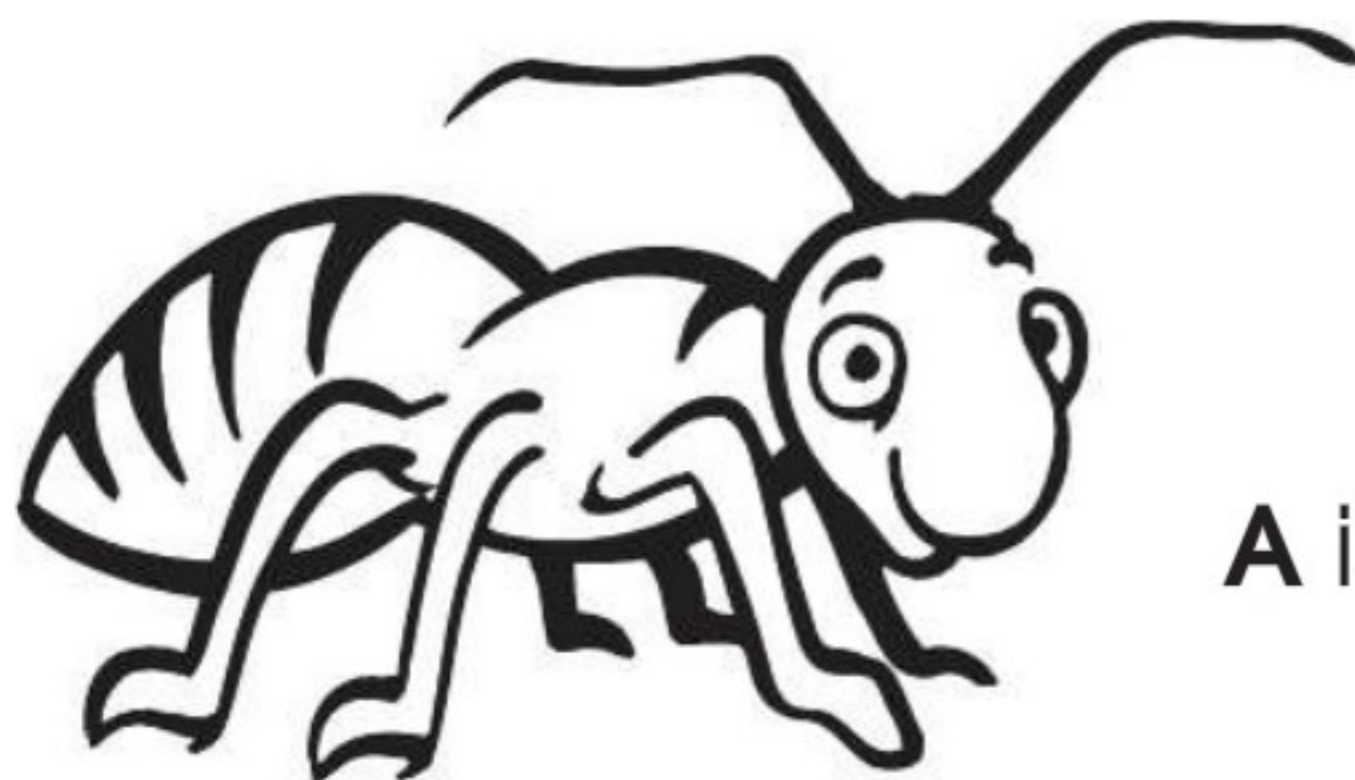



# Letter Bb



**Directions:** Trace and write  the letter **Bb**.

UPPERCASE

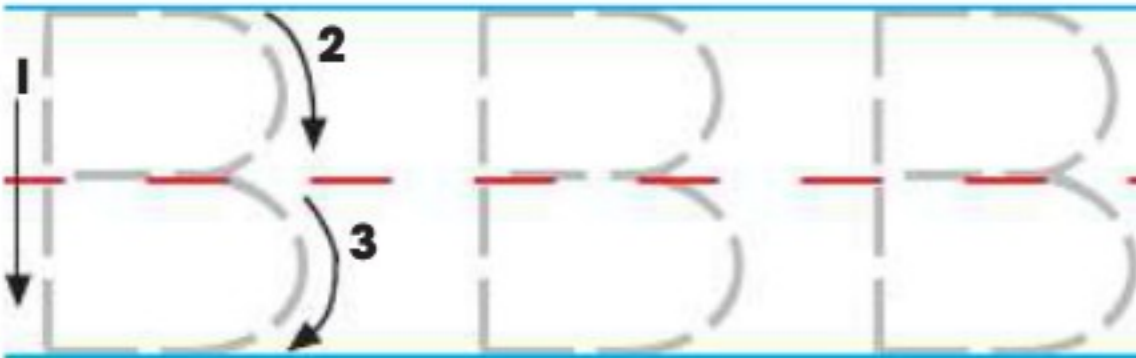

lowercase

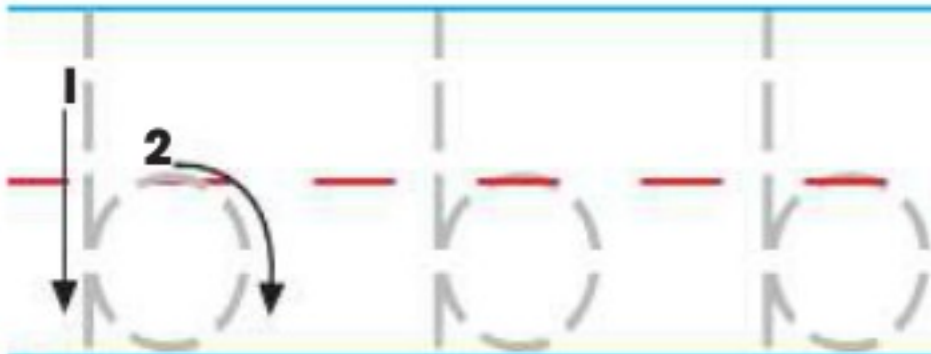

**Directions:** These pictures begin with the letter **Bb**.

**Color**  the pictures.

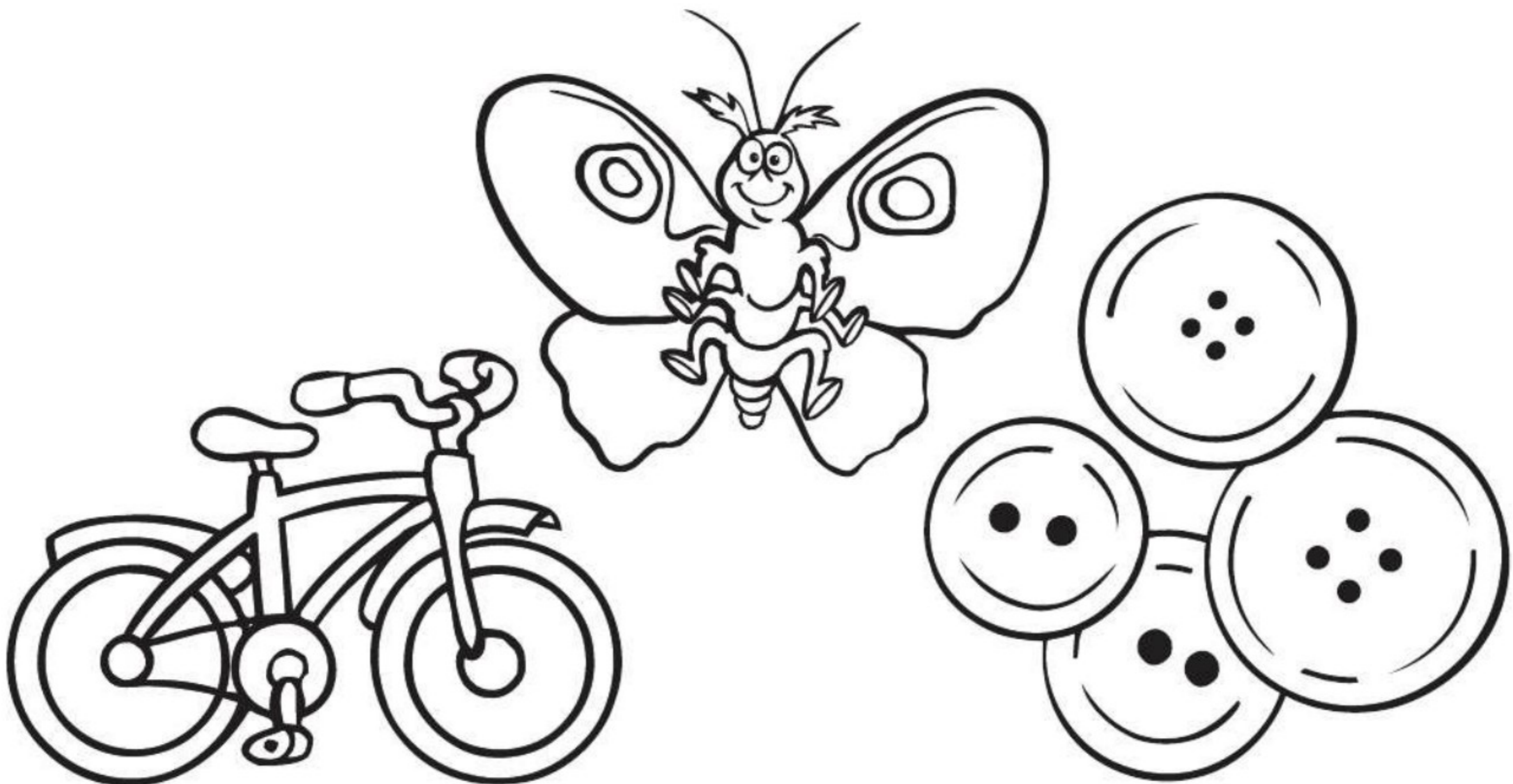



# Letter Bb

Find each hidden **B** and **b**.

**Directions:** Draw  a **blue** circle around each **B** and a **green** circle around each **b**.





# Letter Bb

**Directions:** Circle  the **B** or **b** in these words:

**Bill**

**brown**

**Bonnie**

**boy**

**baby**

**balloon**

**Directions:** Color  the pictures that start with the sound of **Bb**.

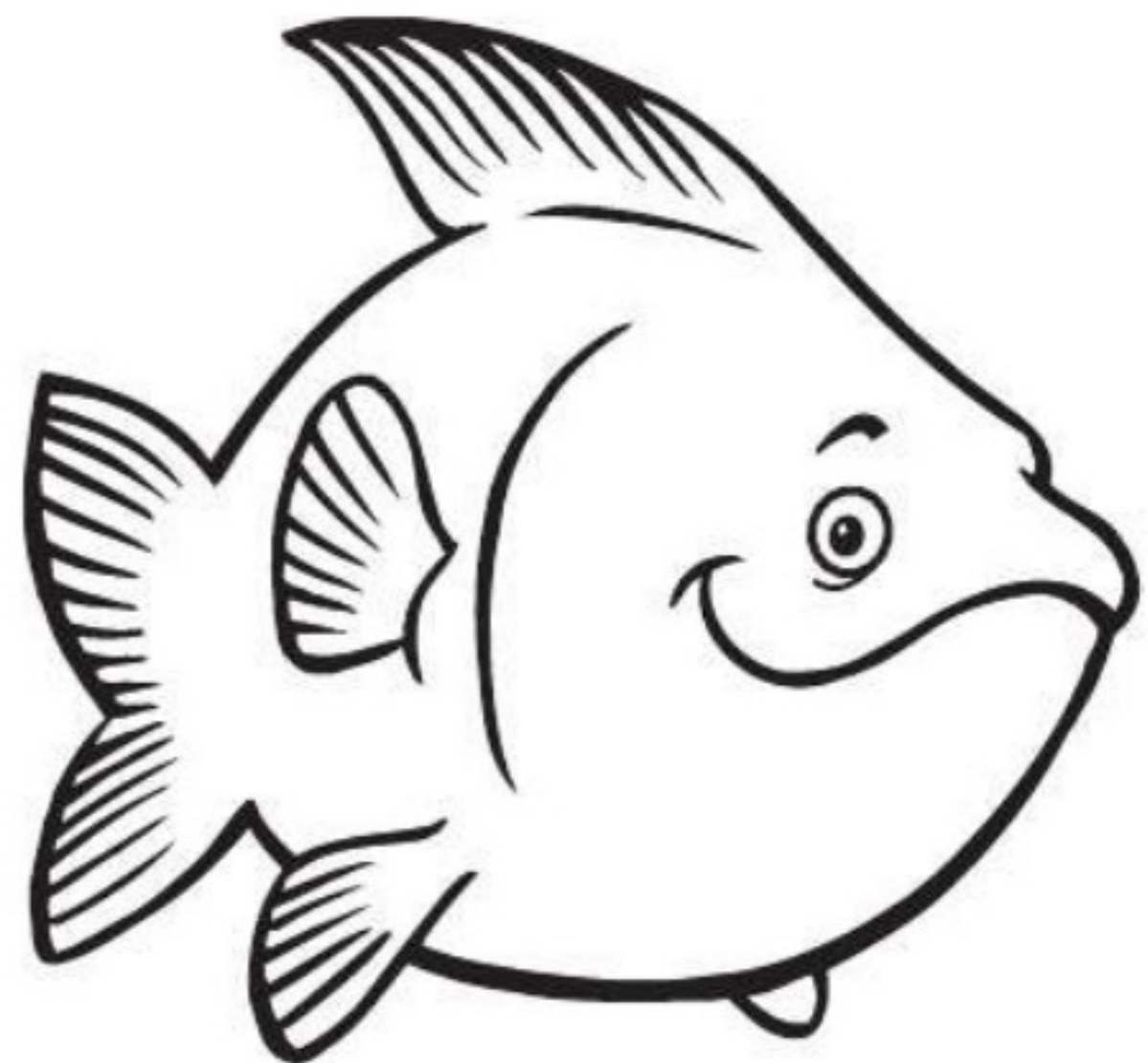
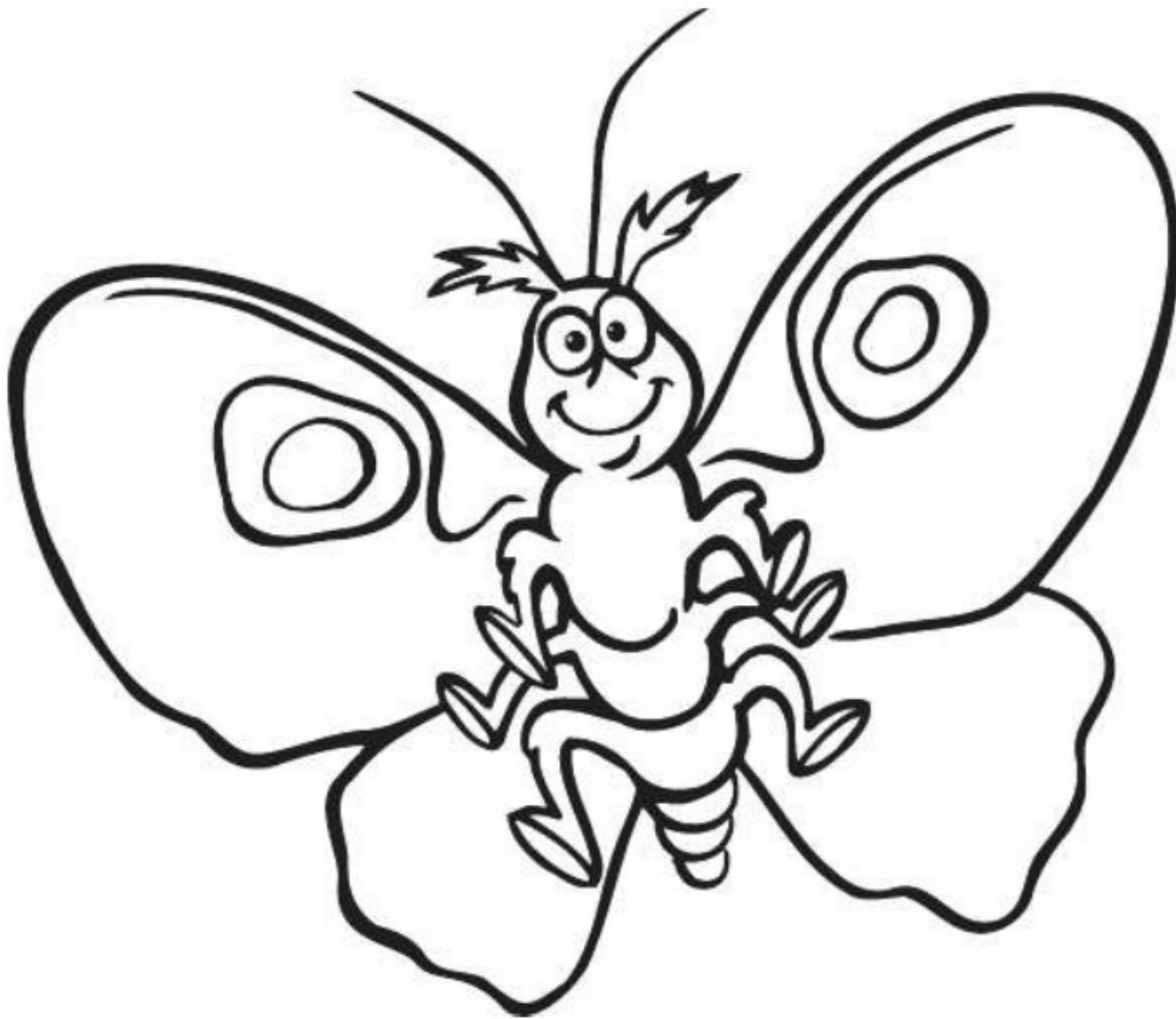



# Letter Bb

These words start with **B** or **b**.

**Directions:** Write  a lowercase **b** on each line.

**Color**  the pictures.



**B** is for uttons.

**B** is for at.

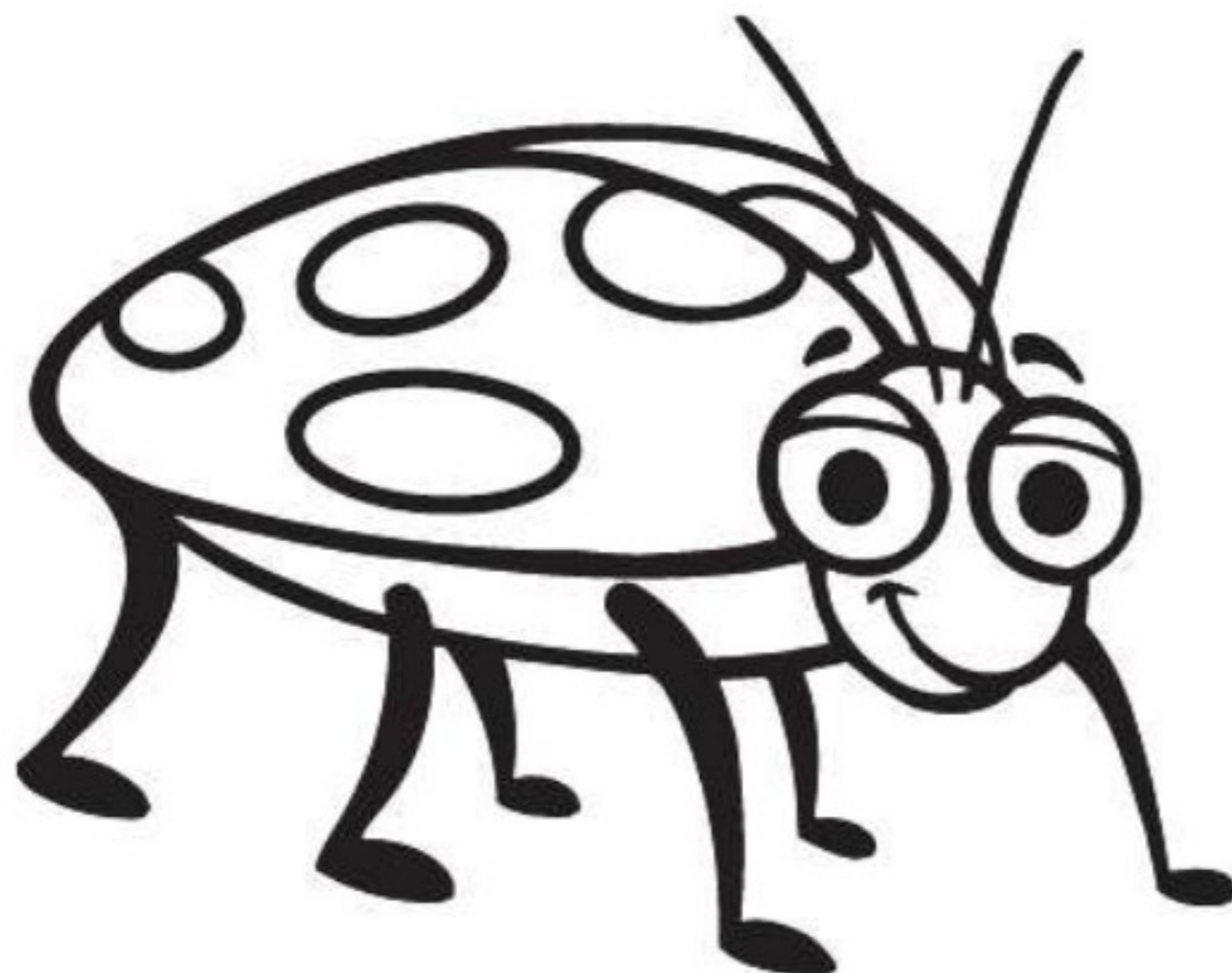
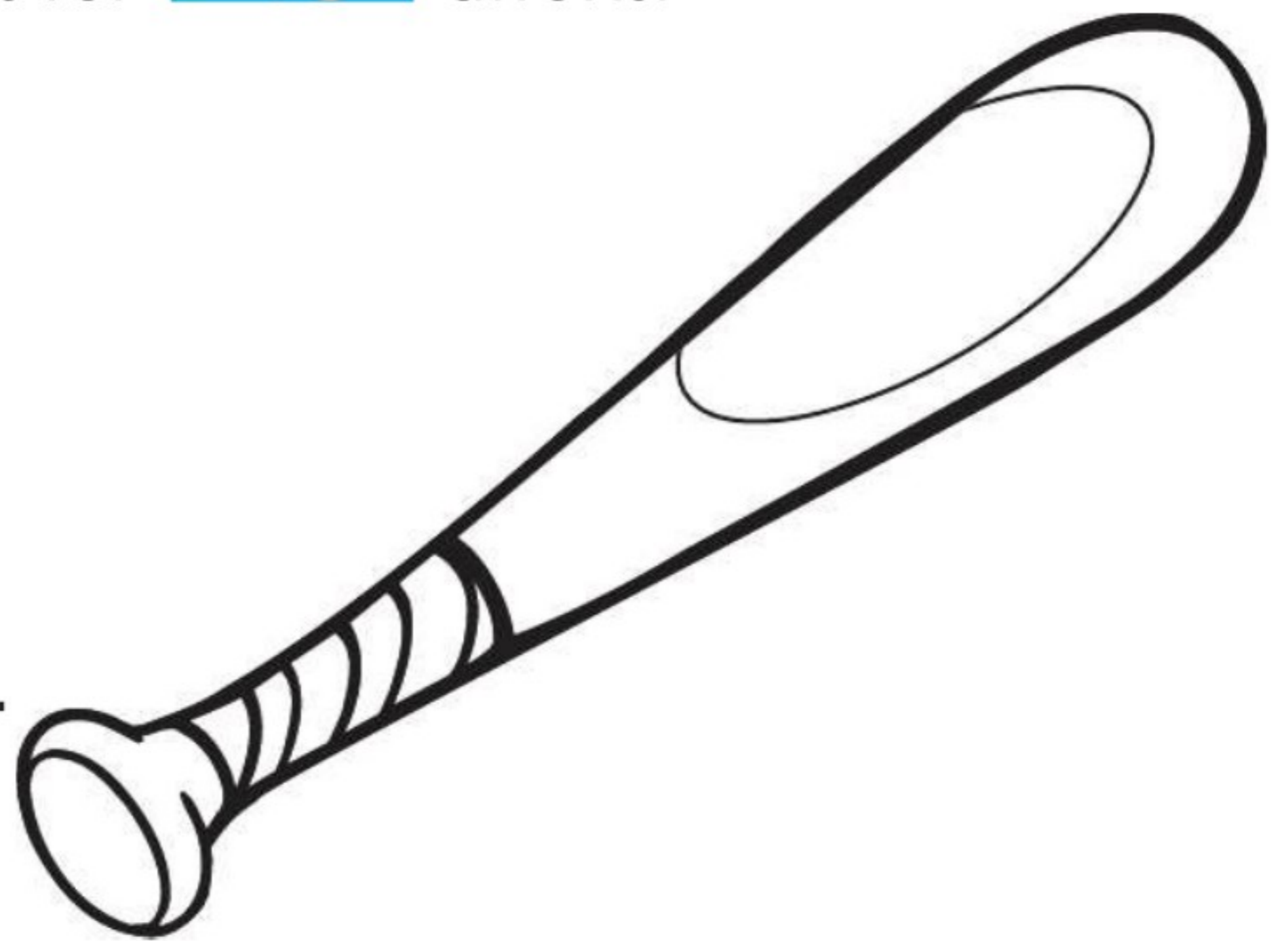

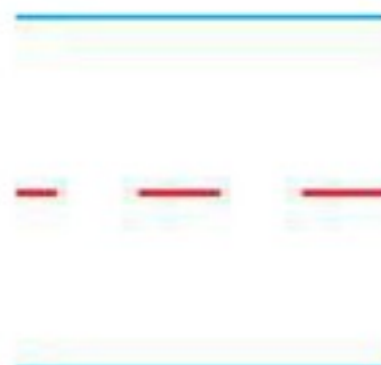
**B** is for ug.



# Letter Cc



**Directions:** Trace and write  the letter Cc.

UPPERCASE



lowercase



**Directions:** These pictures begin with the letter Cc.

**Color**  the pictures.

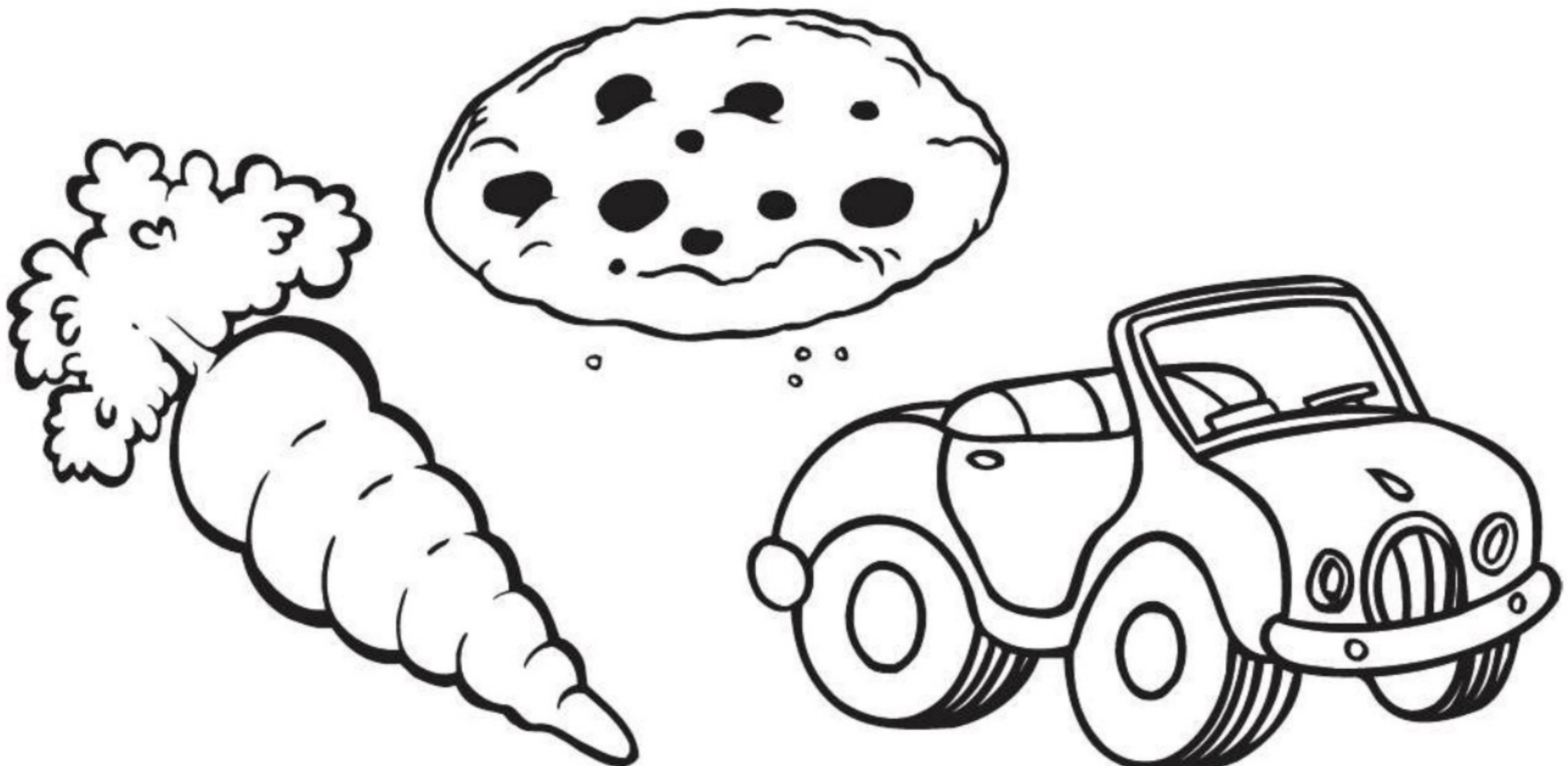



# Letter Cc

Find each **C** and **c** that the cat has made with the yarn.

**Directions:** Color  each **UPPERCASE C** red. Color each lowercase **c** yellow.

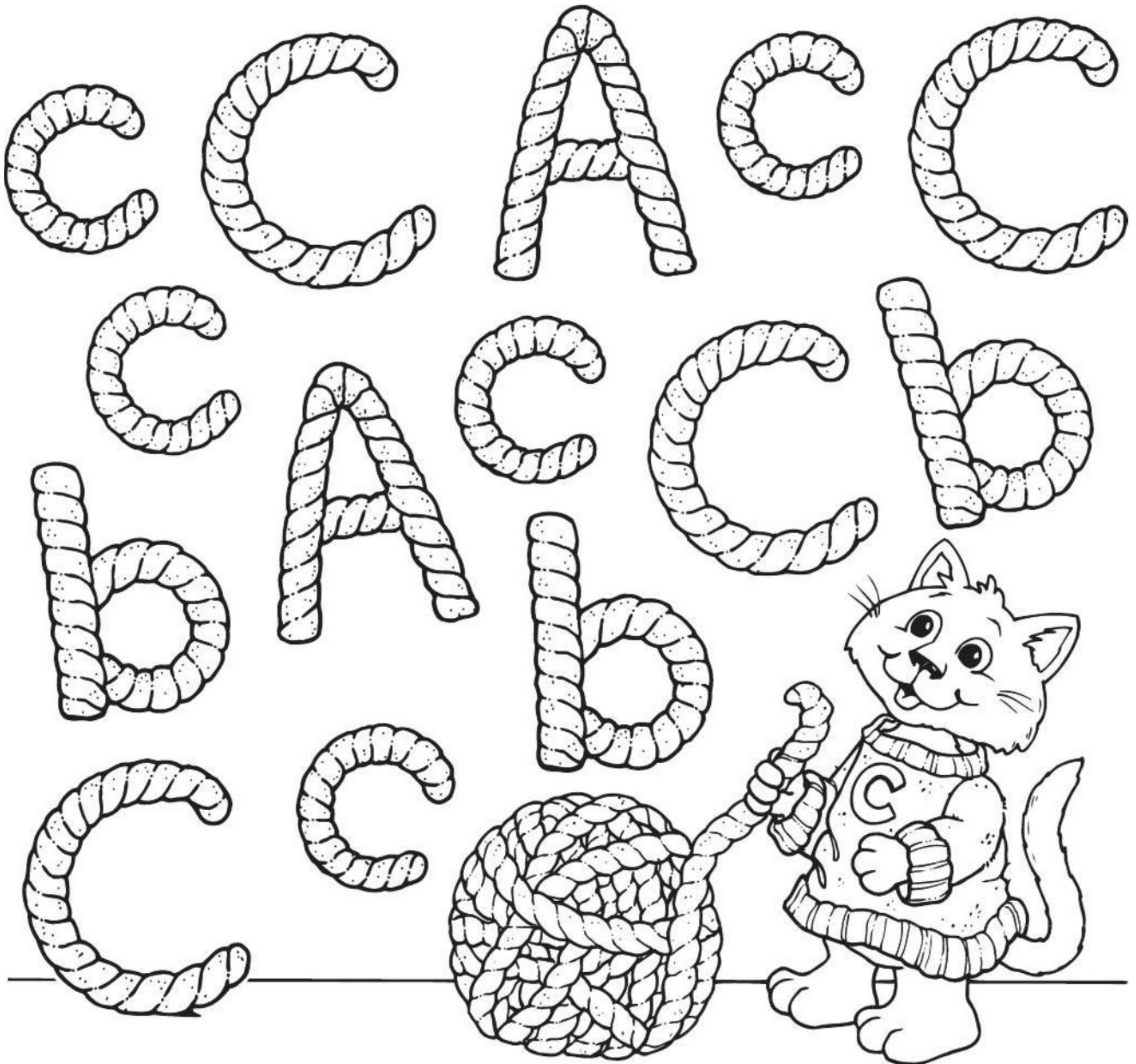



# Letter Cc

**Directions:** Circle  the **C** or **c** in these words:

cat

Casey

can

cow

corn

Carol

**Directions:** Color  the pictures that start with the sound of **Cc**.

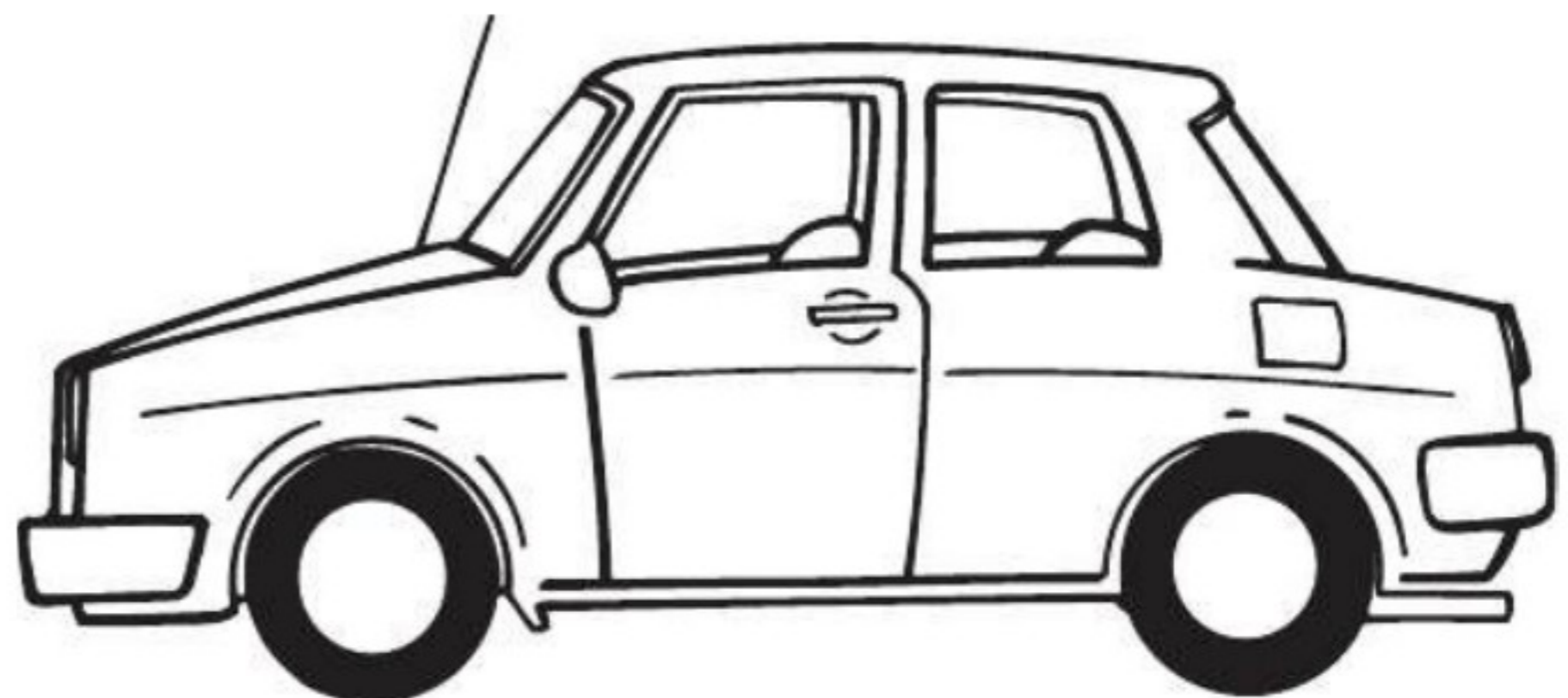
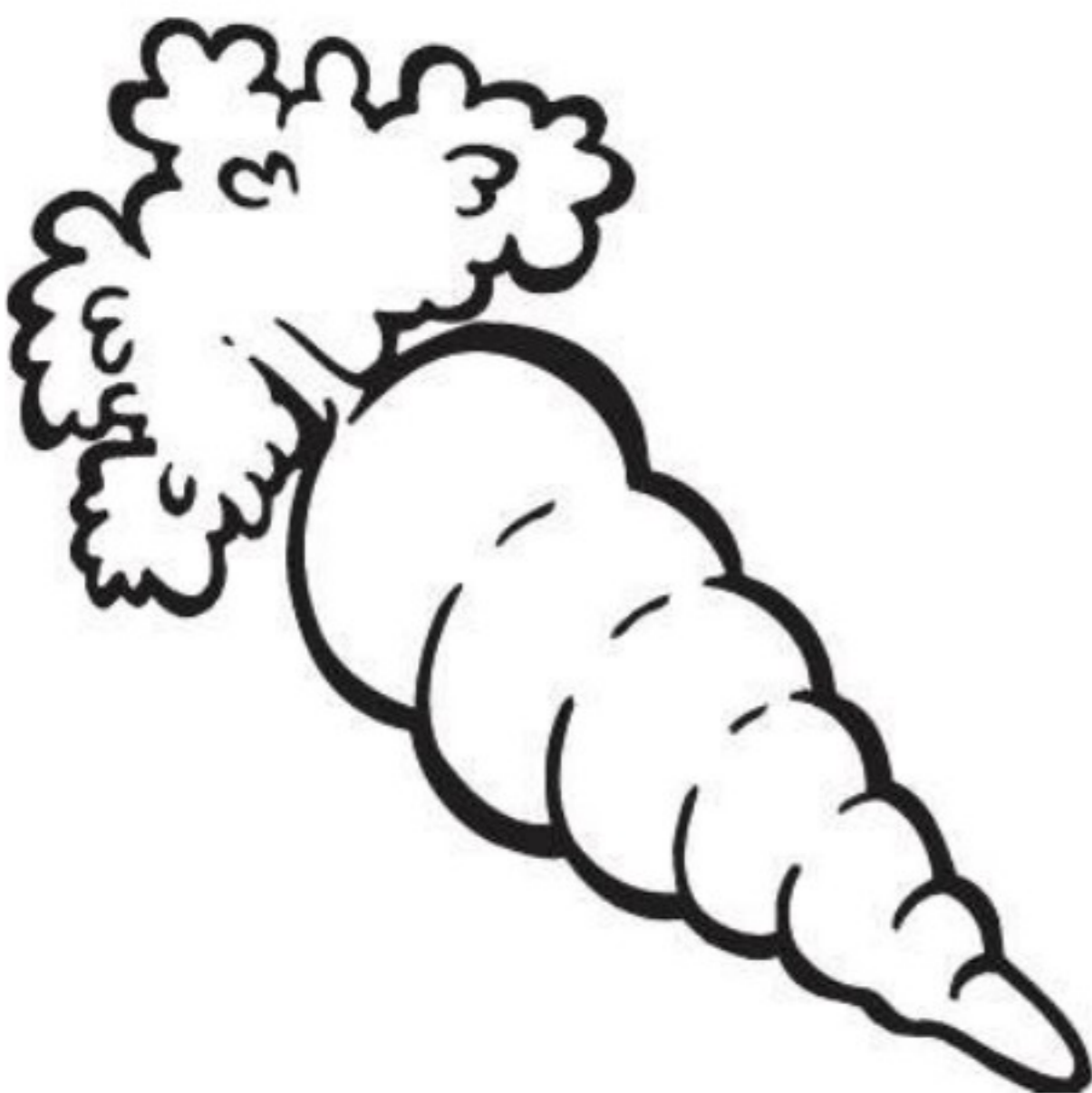
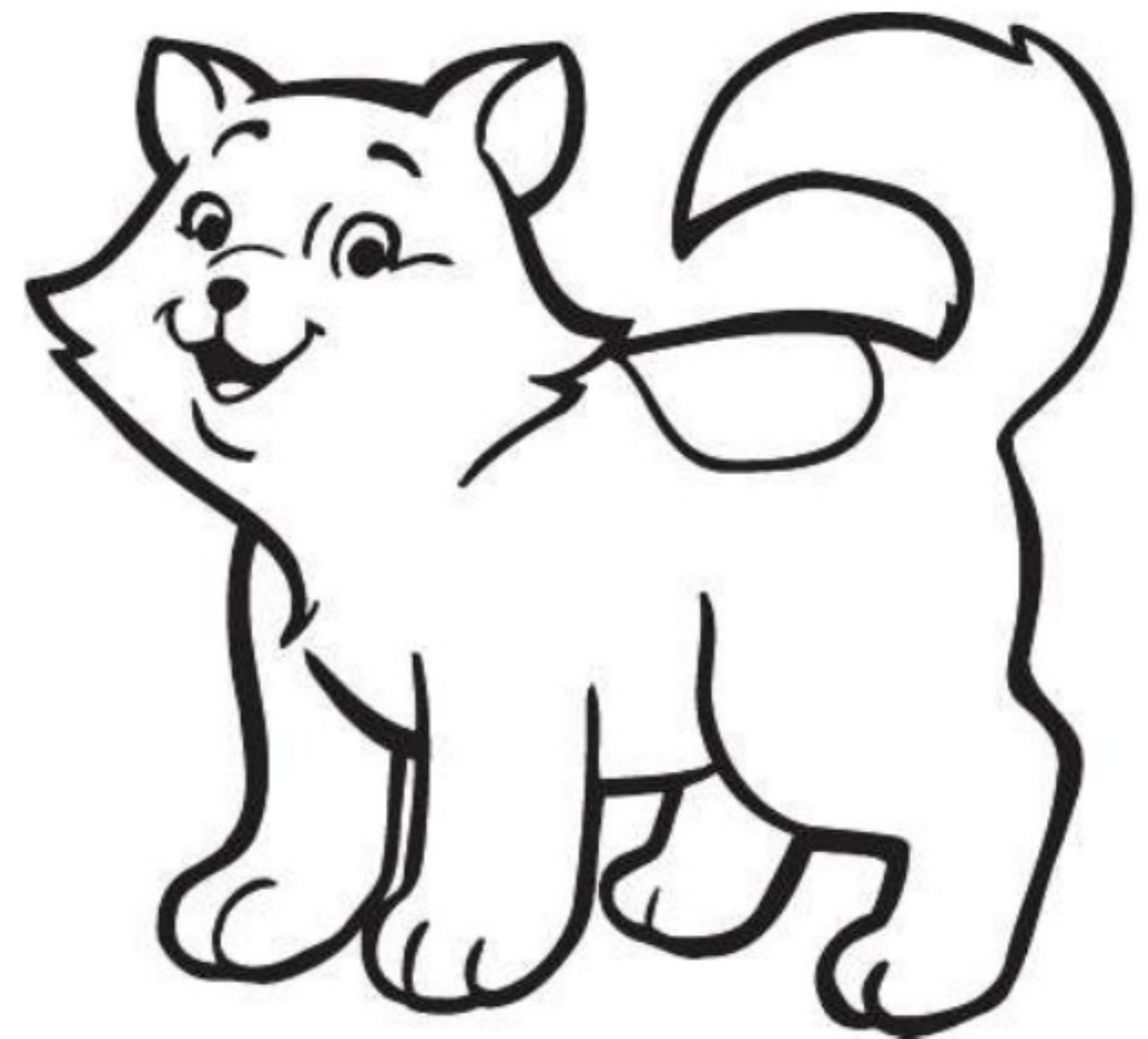
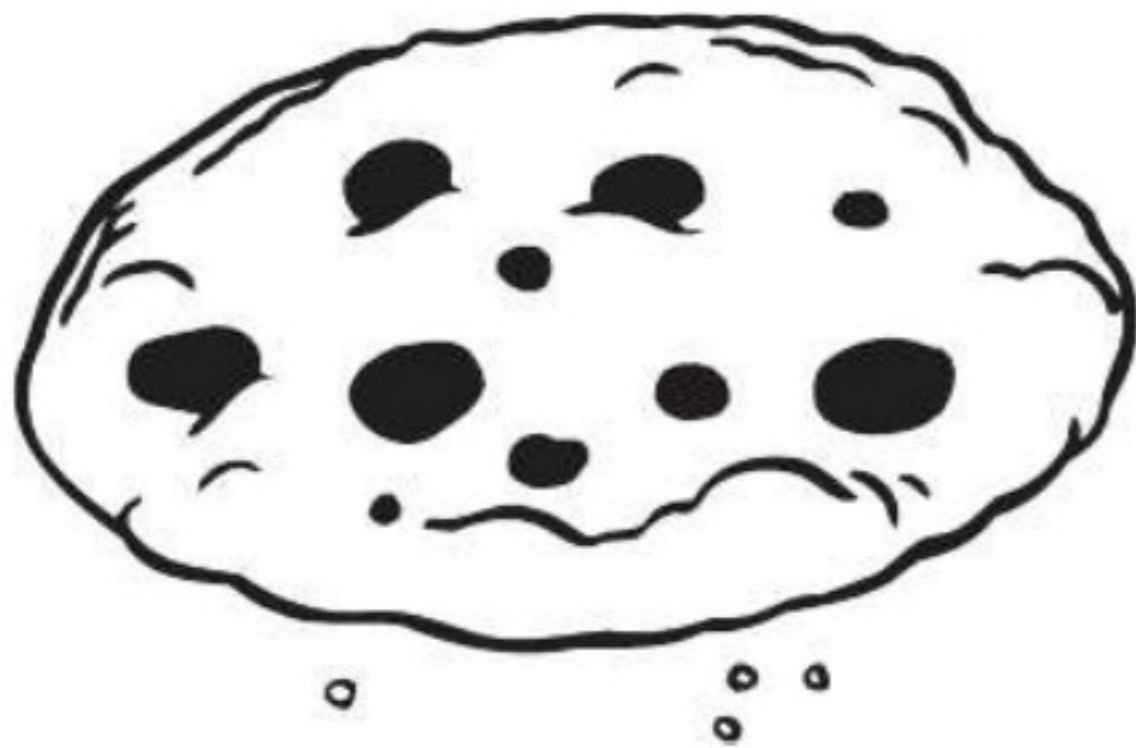







## Letter Cc

Help Calico Cat catch what she is chasing.

**Directions:** Circle  the pictures that begin with the sound of Cc. Color  the pictures.





# Letter Dd



**Directions:** Trace and write  the letter **Dd**.

UPPERCASE

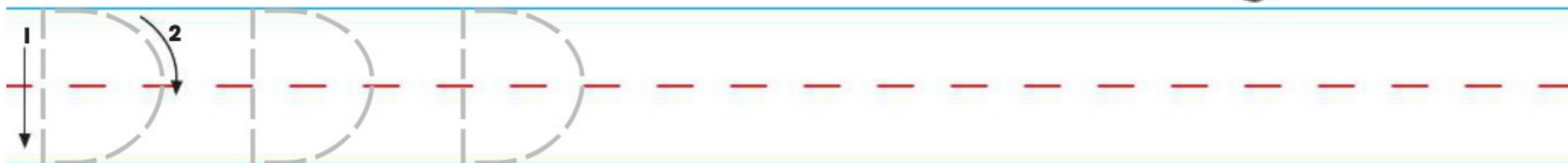

lowercase



**Directions:** These pictures begin with the letter **Dd**.

**Color**  the pictures.

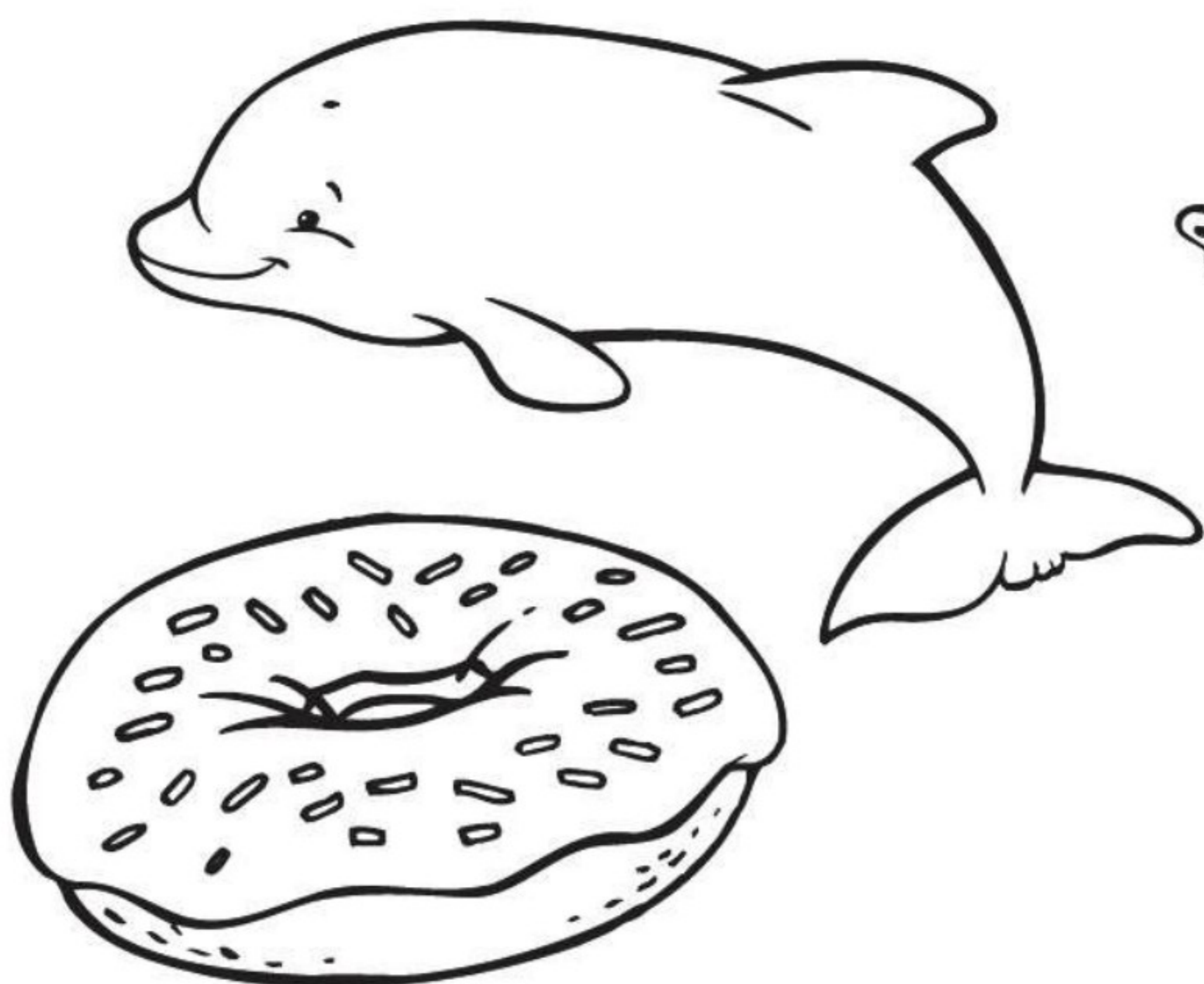



# Letter Dd

**Directions:** Color  the spaces with the letters **D** or **d** purple.

Color  the spaces with the other letters orange.

What did you find?

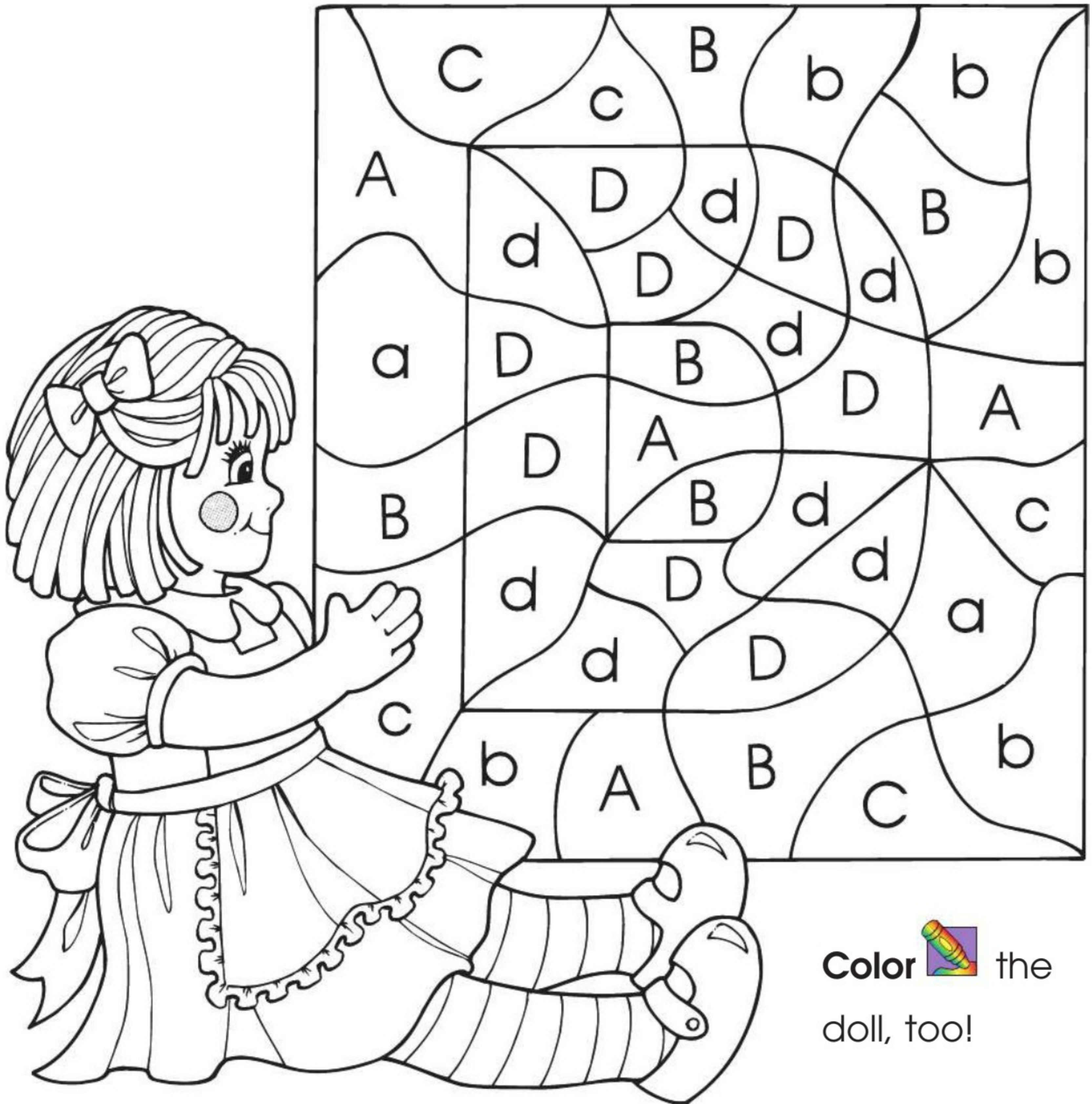

The grid contains the following letters in each cell (row by row):

C	c	B	b	b
A	D	d	D	B
a	D	B	d	b
B	D	A	D	A
a	D	B	d	c
d	D	d	d	a
b	A	B	C	b

Color  the doll, too!



# Letter Dd

**Directions:** Circle  the **D** or **d** in these words:

doll

Darcy

desk

door

David

dog

**Directions:** Color  the pictures that start with the sound of **Dd**.





# Letter Dd

These words start with **D** or **d**.

**Directions:** Write  a lowercase **d** on each line.

**Color**  the pictures.



**D** is for  og.

**D** is for \_\_\_\_\_ rum.



**D** is for \_\_\_\_\_ uck.

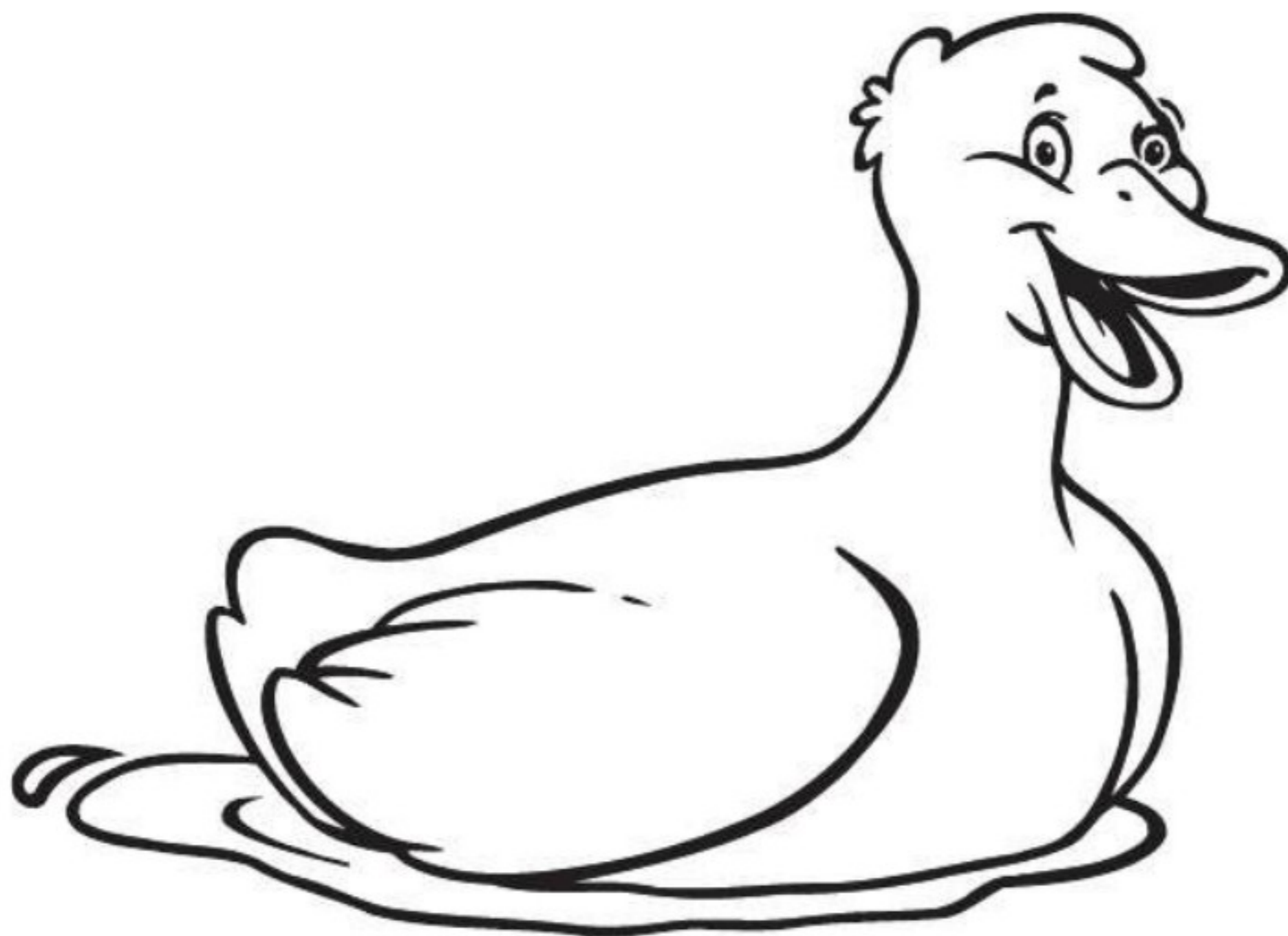



# Letter Ee

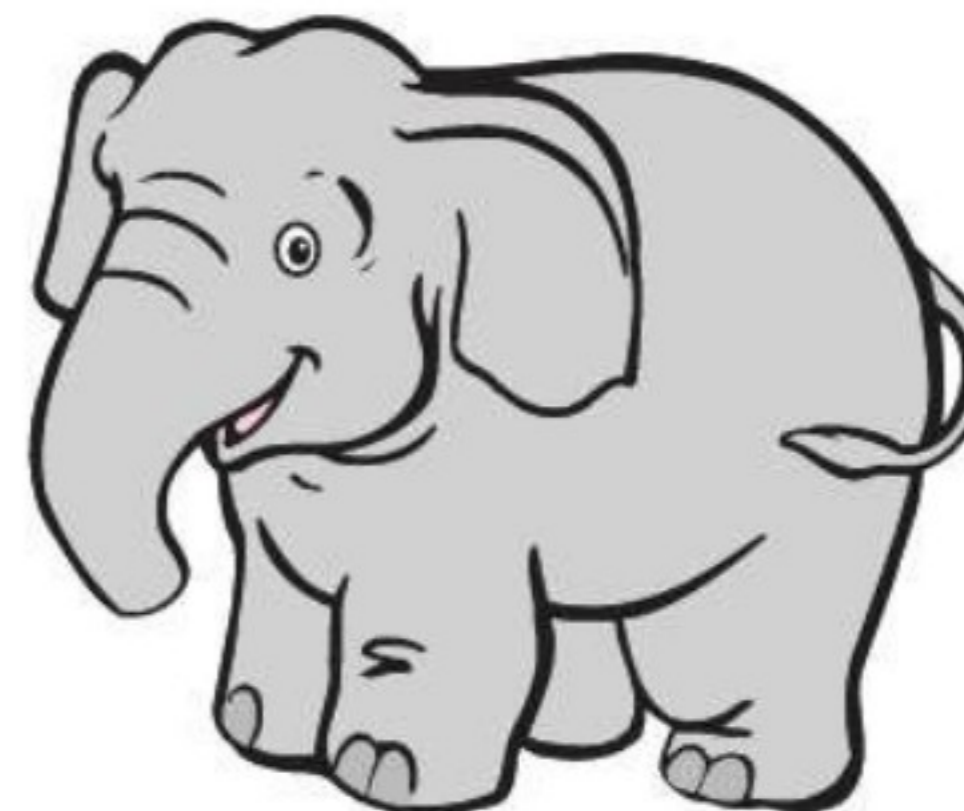

**Directions:** Trace and write  the letter **Ee**.

UPPERCASE



lowercase



**Directions:** These pictures begin with the letter **Ee**.



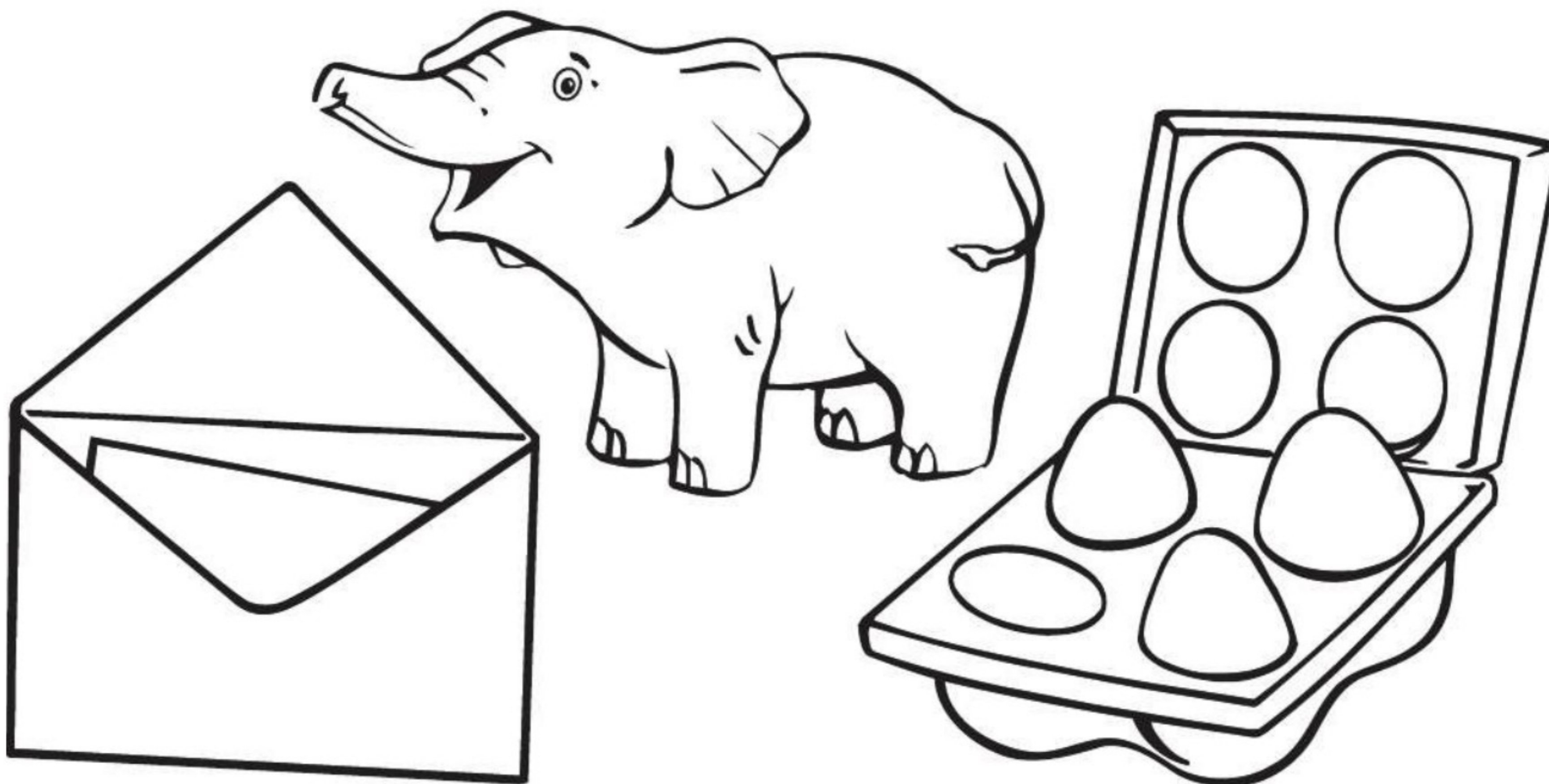

**Color**  the pictures.





## Letter Ee

Help the  find its way to the circus tent.

**Directions:** Color  the s with **E** or **e** **brown**. Color  the other s **green**. Color  the rest of the picture.

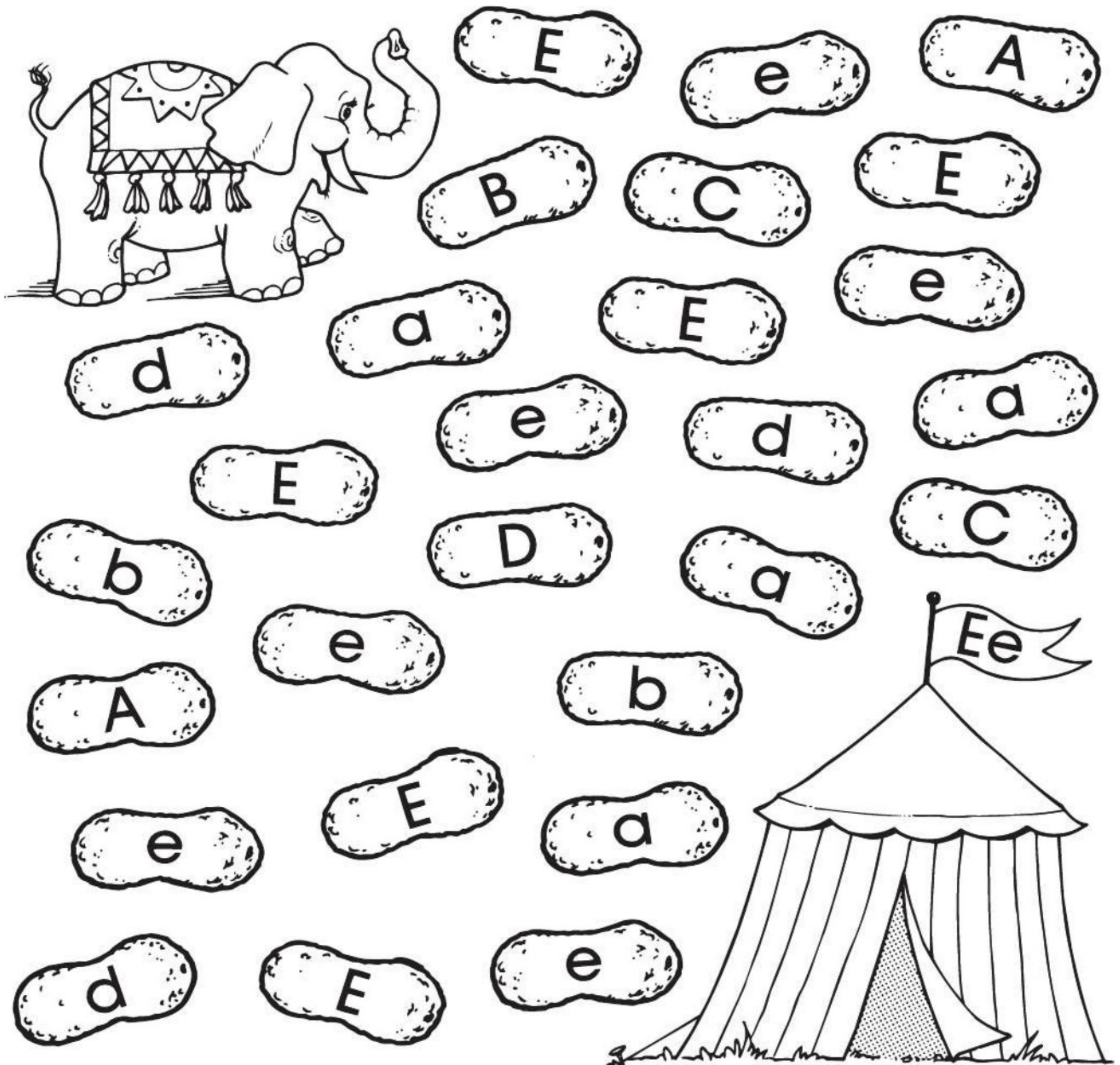



# Letter Ee

**Directions:** Circle  the **E** or **e** in these words:

ear

Elizabeth

eleven

earth

Eric

elf

The letter **Ee** can have more than one sound.

**Directions:** Color  the pictures that start with the sound of **Ee**.

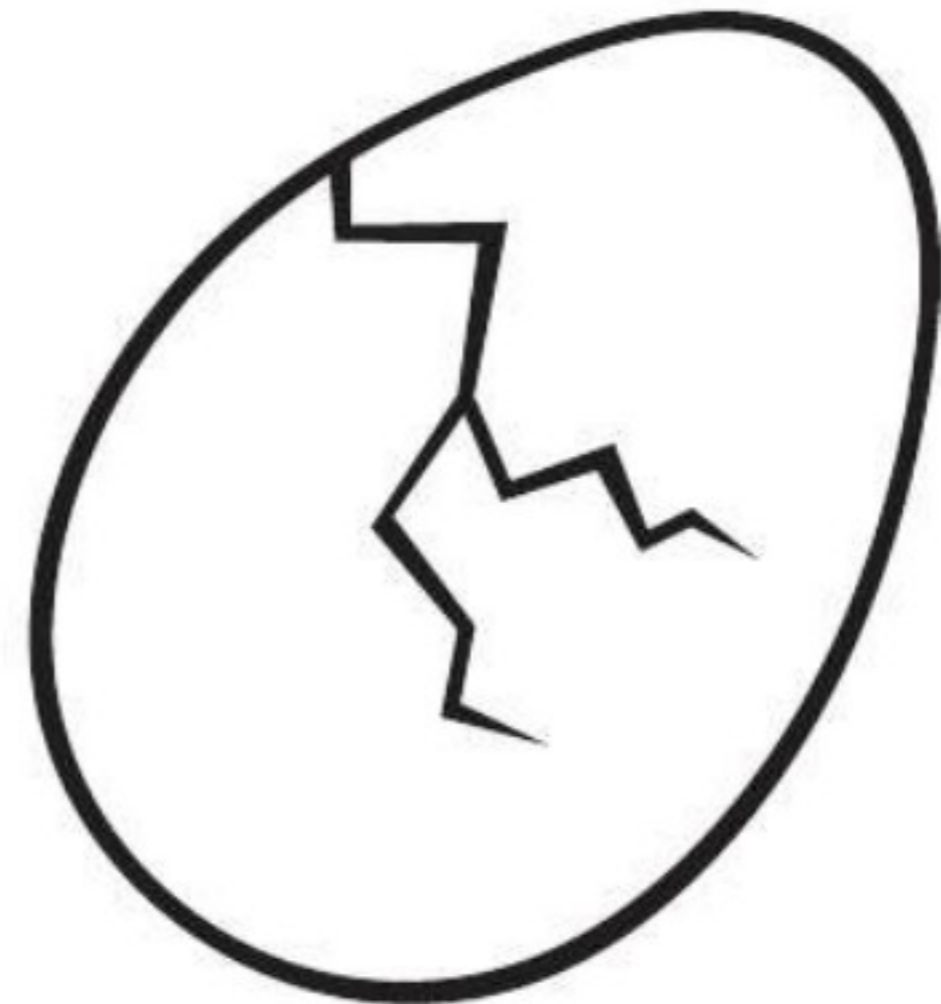
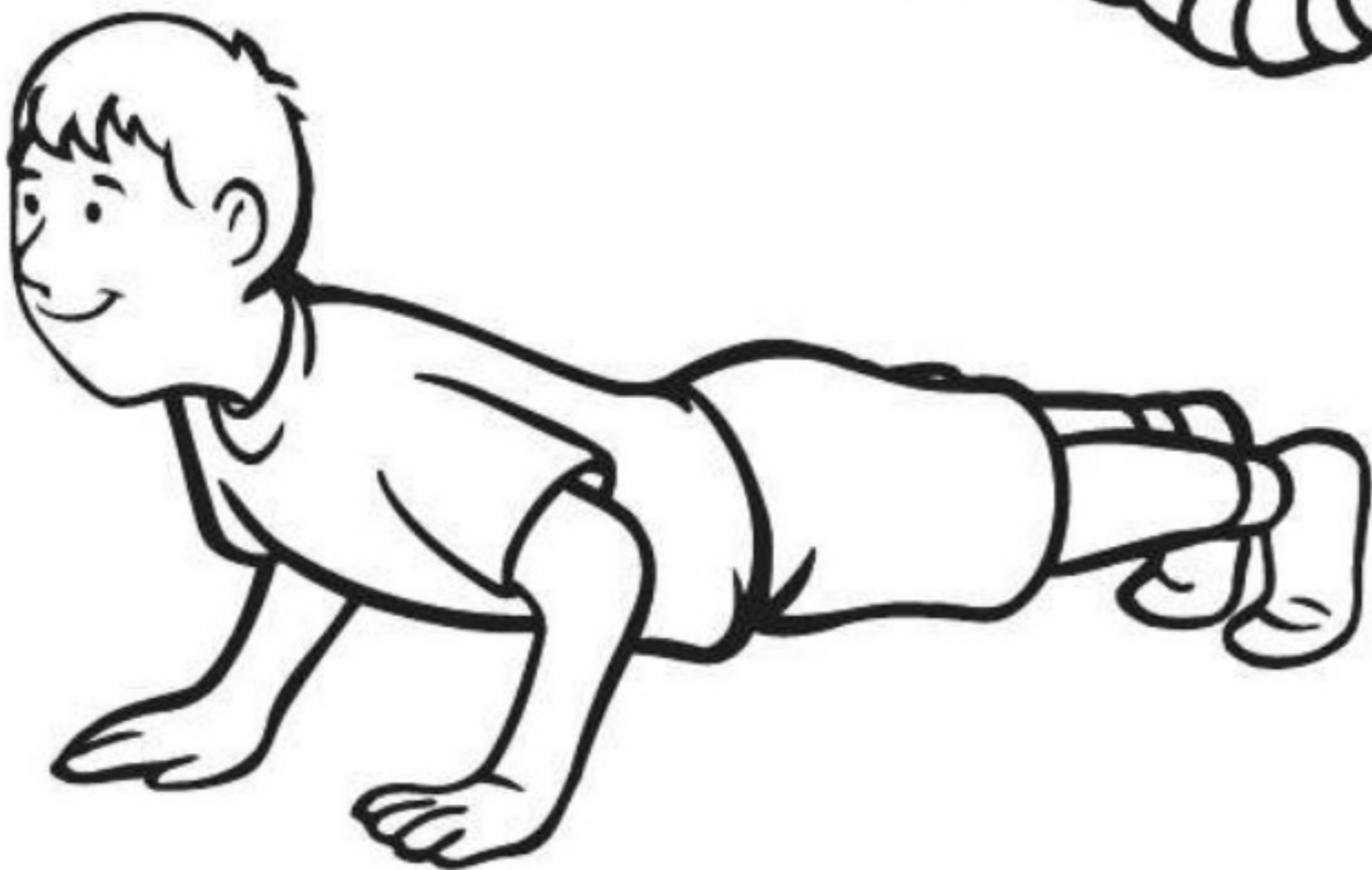
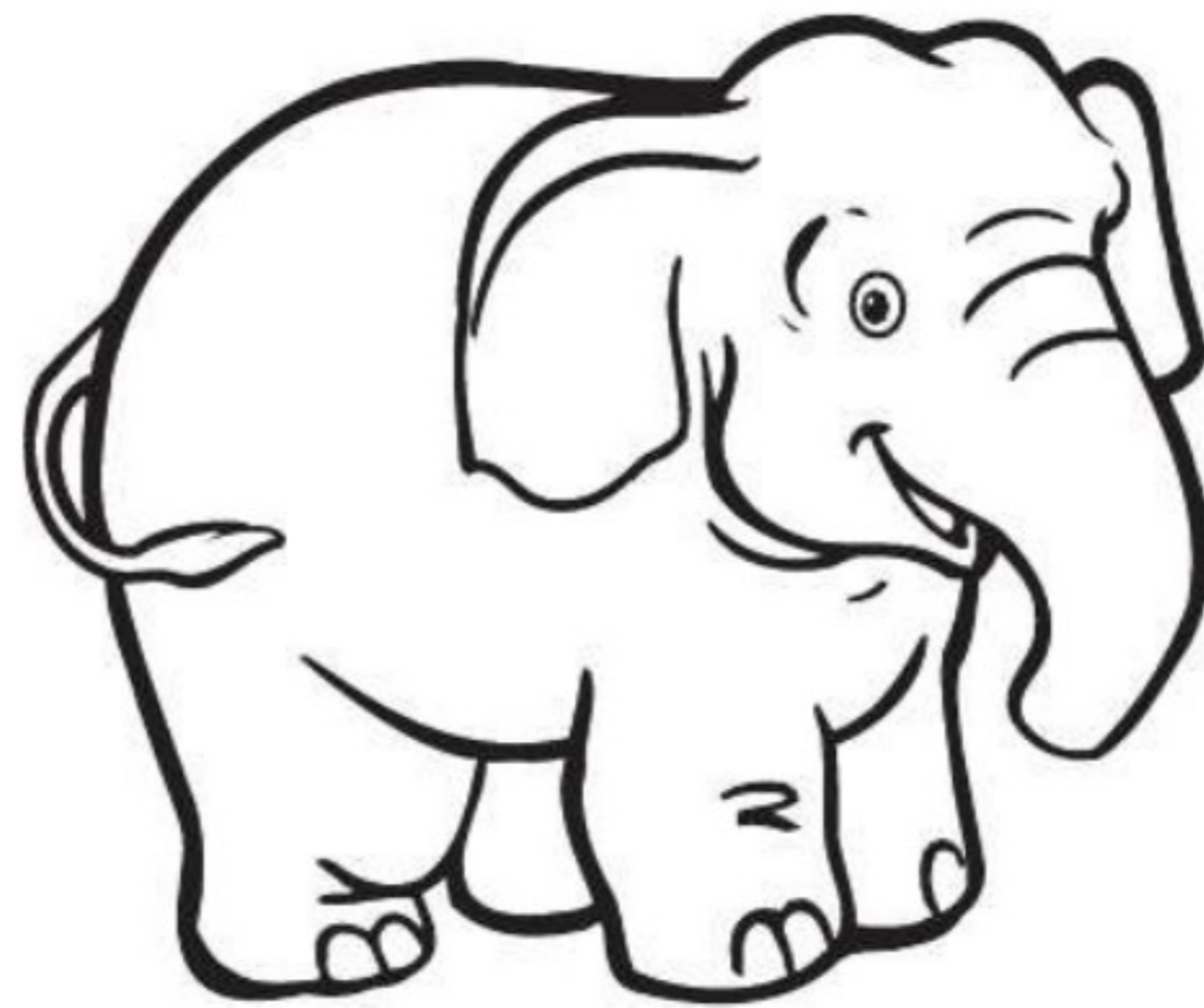





# Letter Ee

These words start with **E** or **e**.

**Directions:** Write  a lowercase **e** on each line.

**Color**  the pictures.

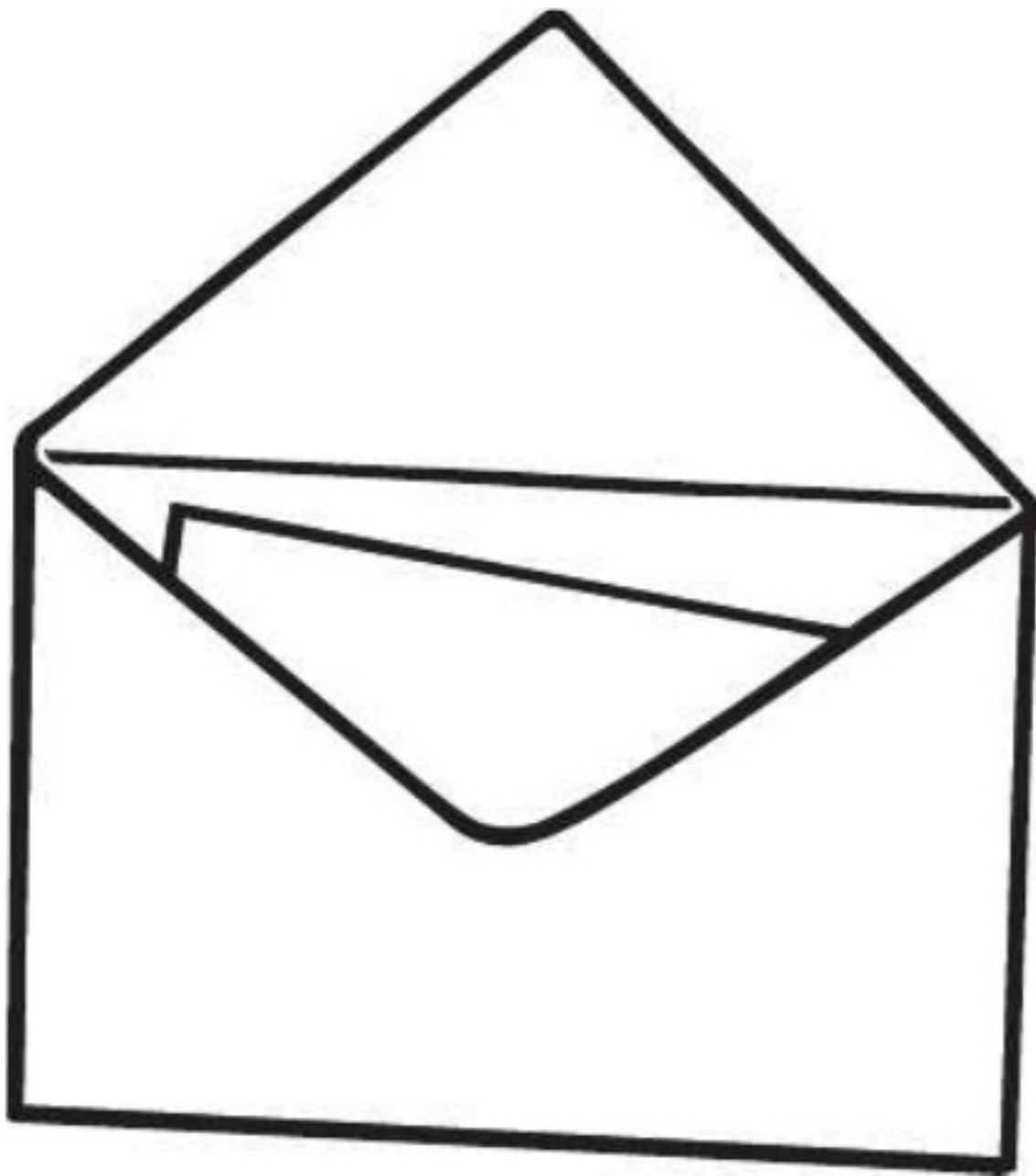

\_\_\_\_\_   
 - - - - -   
 **E** is for \_\_\_\_\_ nvelope.



\_\_\_\_\_   
 - - - - -   
 **E** is for \_\_\_\_\_ ggs.

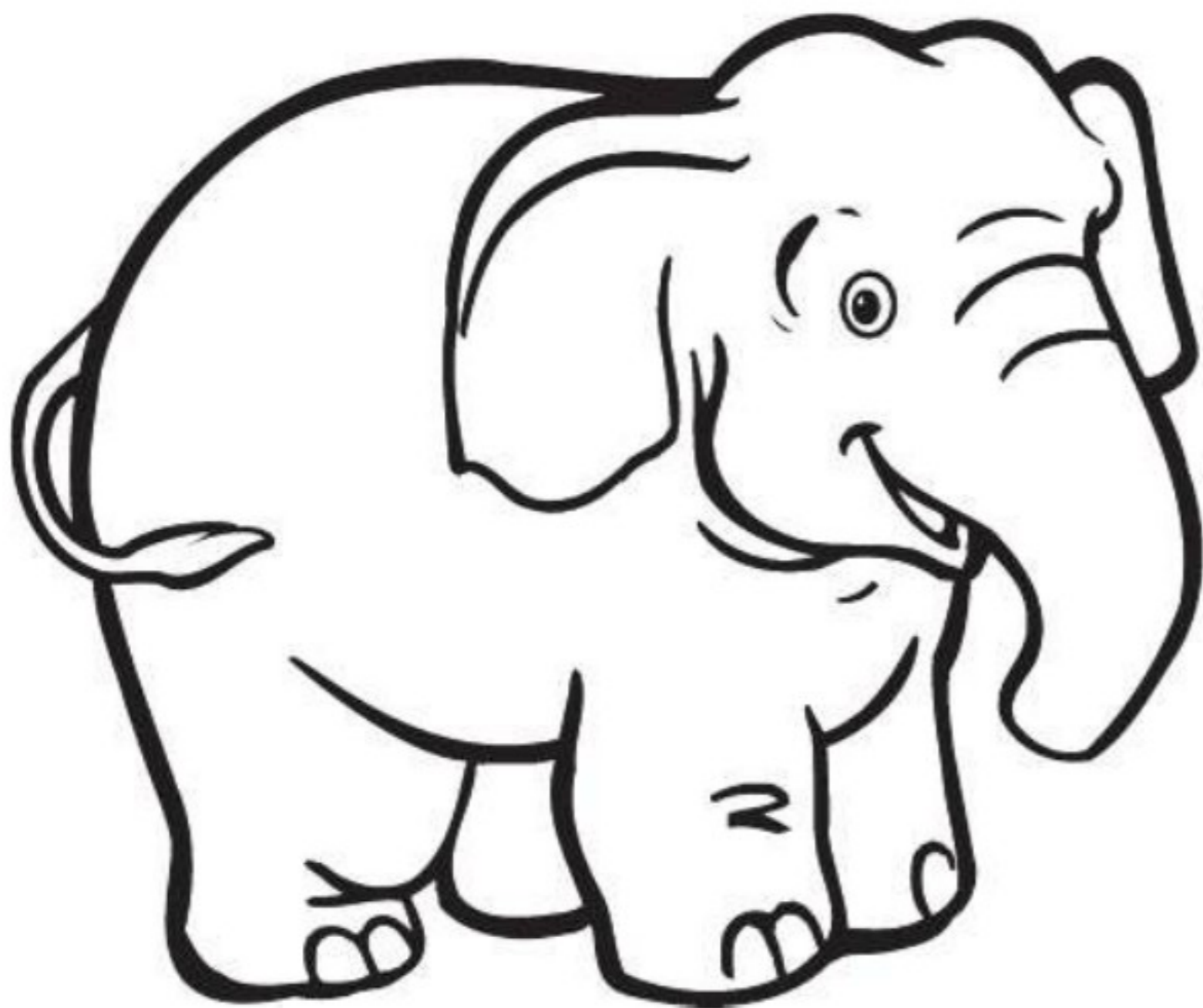

\_\_\_\_\_   
 - - - - -   
 **E** is for \_\_\_\_\_ lephant.



# Letter Ff

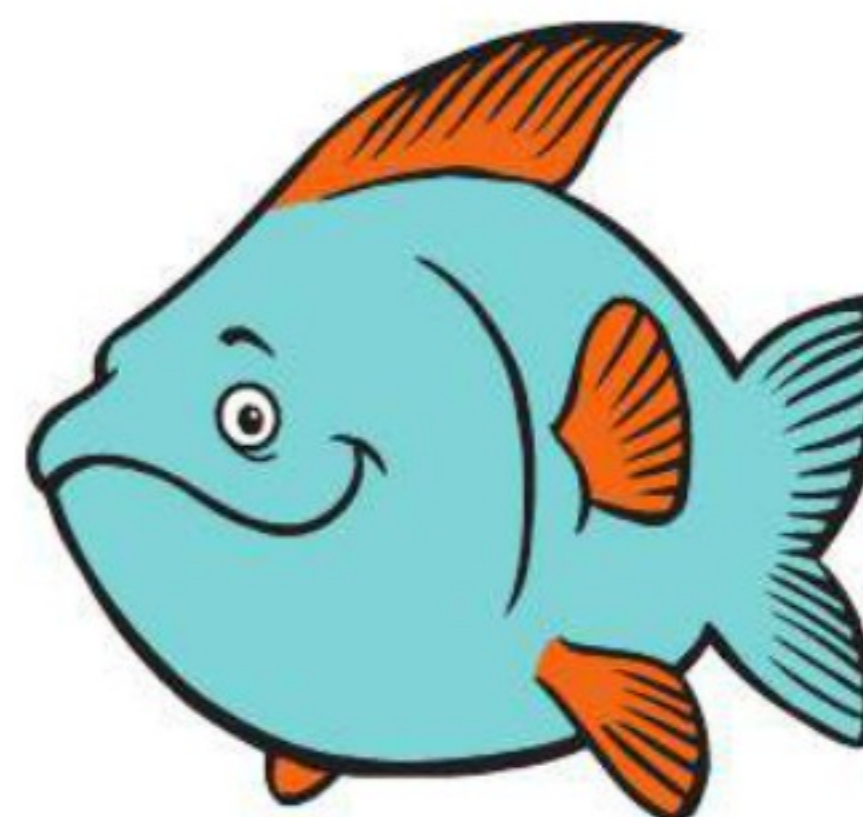

**Directions:** Trace and write  the letter **Ff**.

UPPERCASE



lowercase

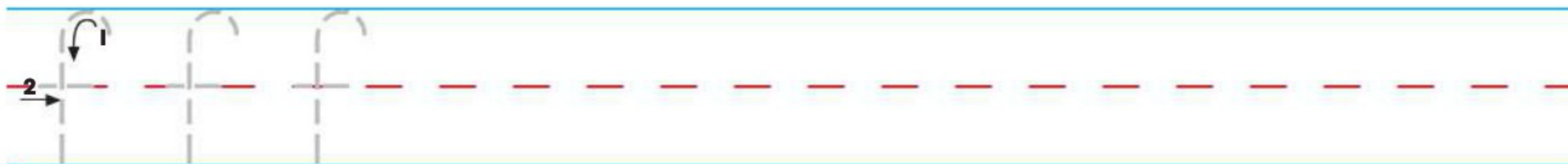

**Directions:** These pictures begin with the letter **Ff**.

**Color**  the pictures.

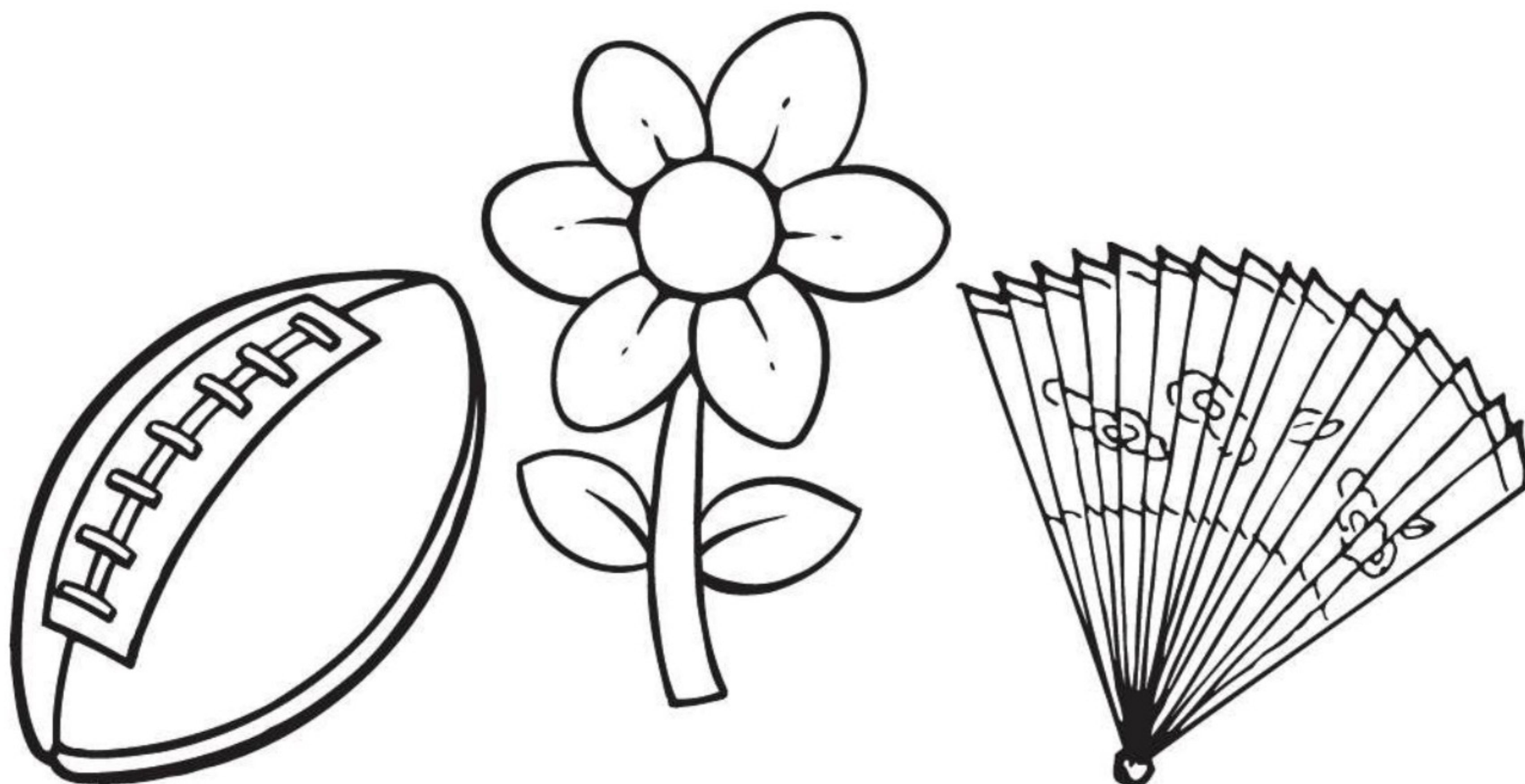





# Letter Ff

Help the firefighter find each **F** and **f**.

**Directions:** Color  a **blue**  of water around each **F**.

Color  a **green**  of water around each **f**. Color  the picture.

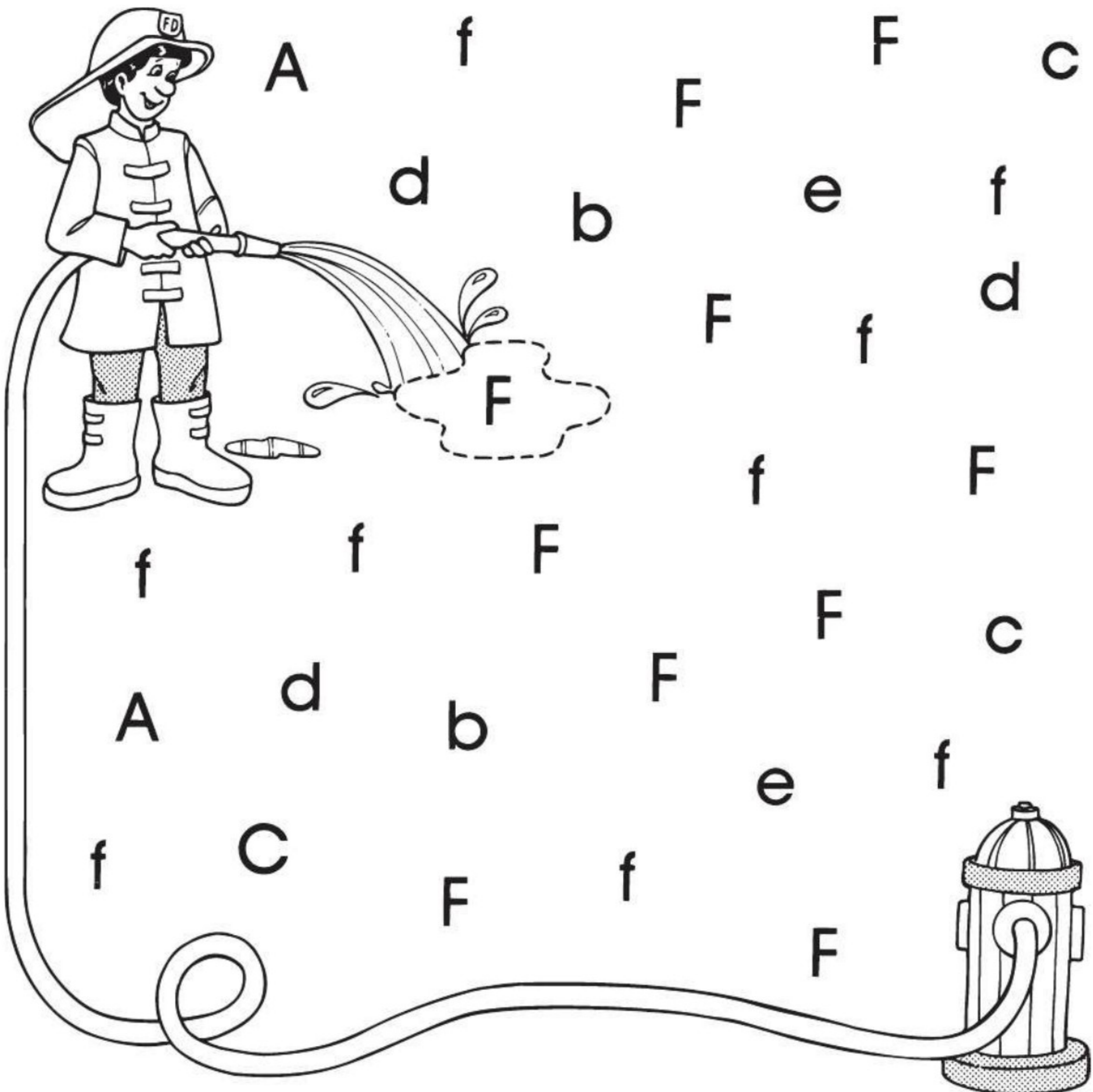



# Letter Ff

**Directions:** Circle  the **F** or **f** in these words:

fire

Faye

fork

Fred

farm

fish

**Directions:** Color  the pictures that start with the sound of **Ff**.

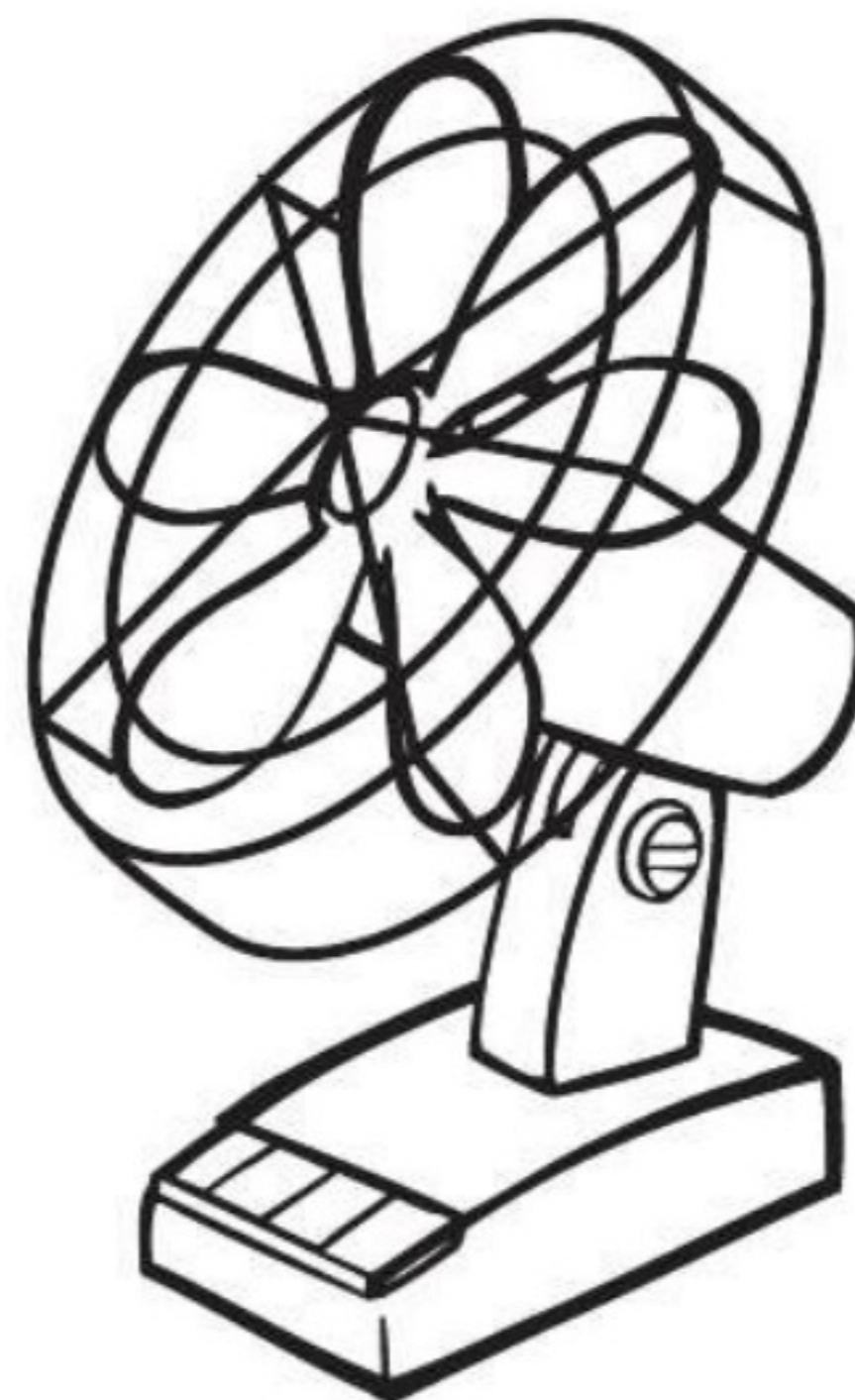
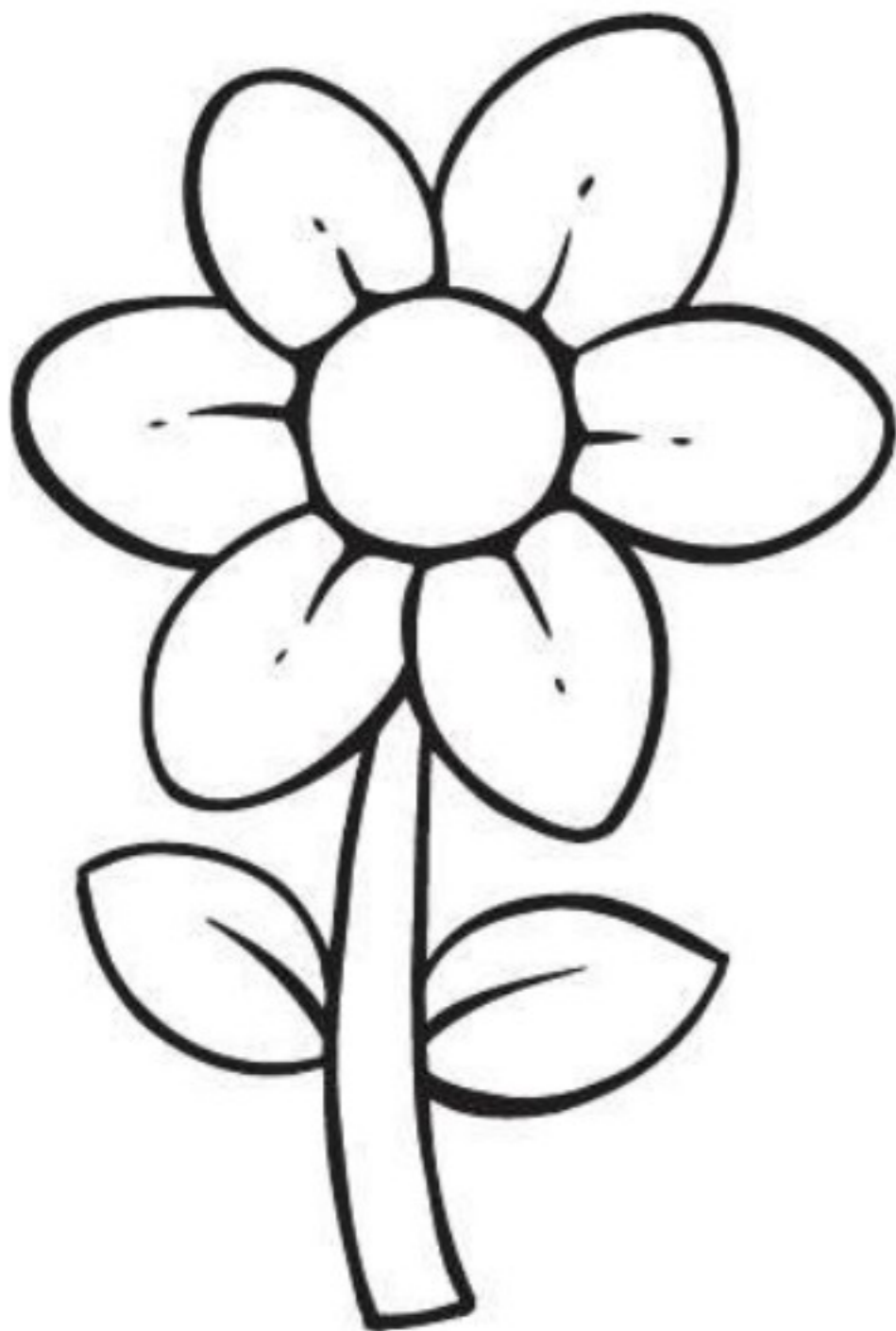



# Letter Ff

**Directions:** Color  each picture on the fence that begins with the sound of **Ff**.

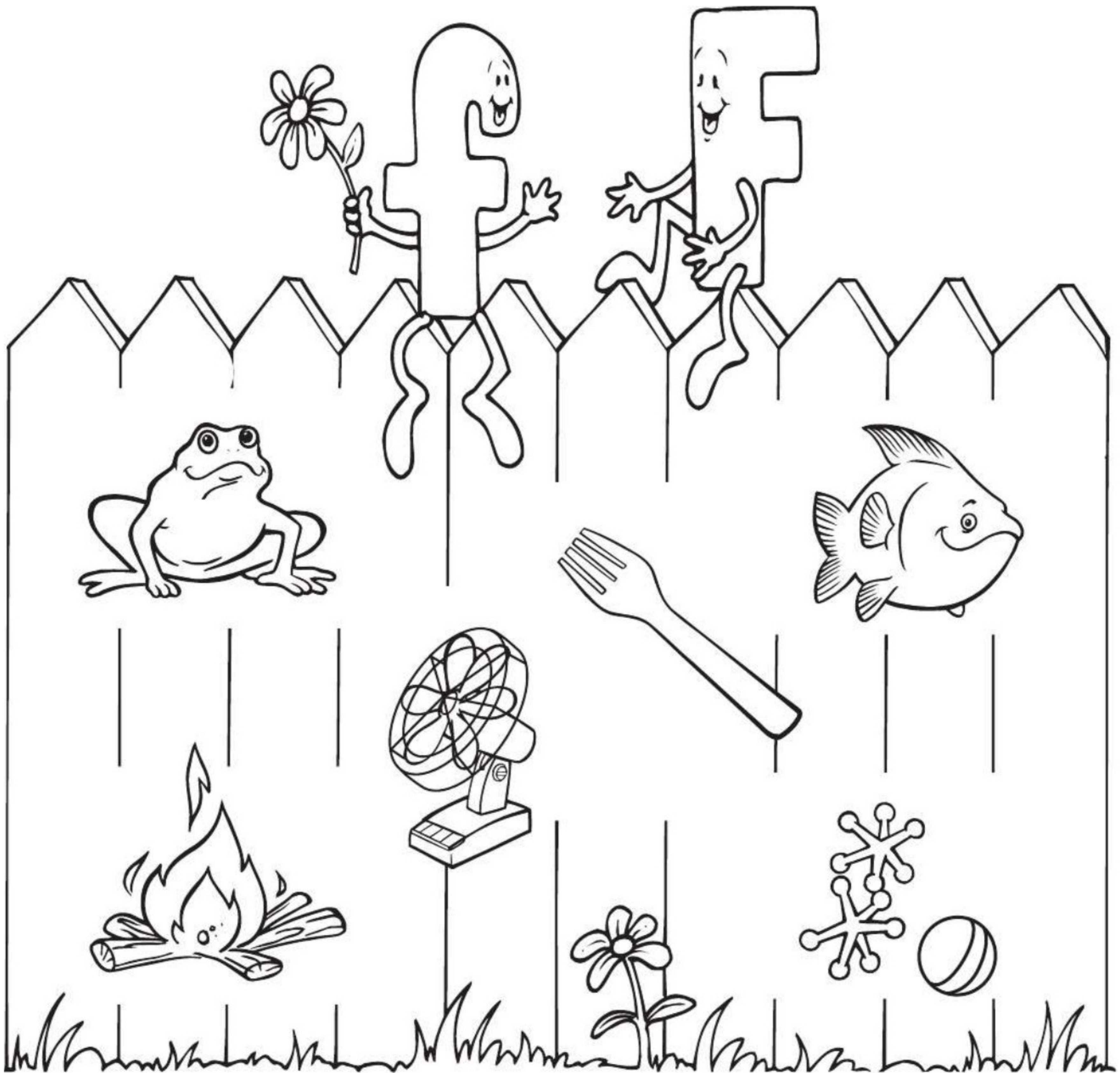



# Letter Gg

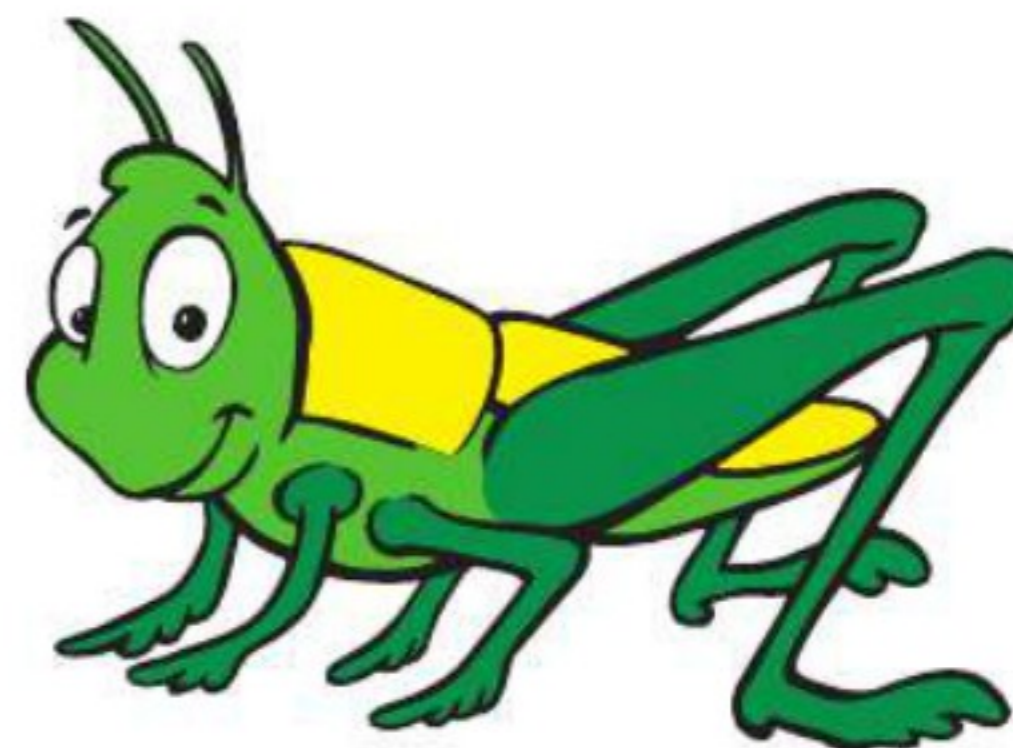

**Directions:** Trace and write  the letter **Gg**.

UPPERCASE



lowercase



**Directions:** These pictures begin with the letter **Gg**.

**Color**  the pictures.

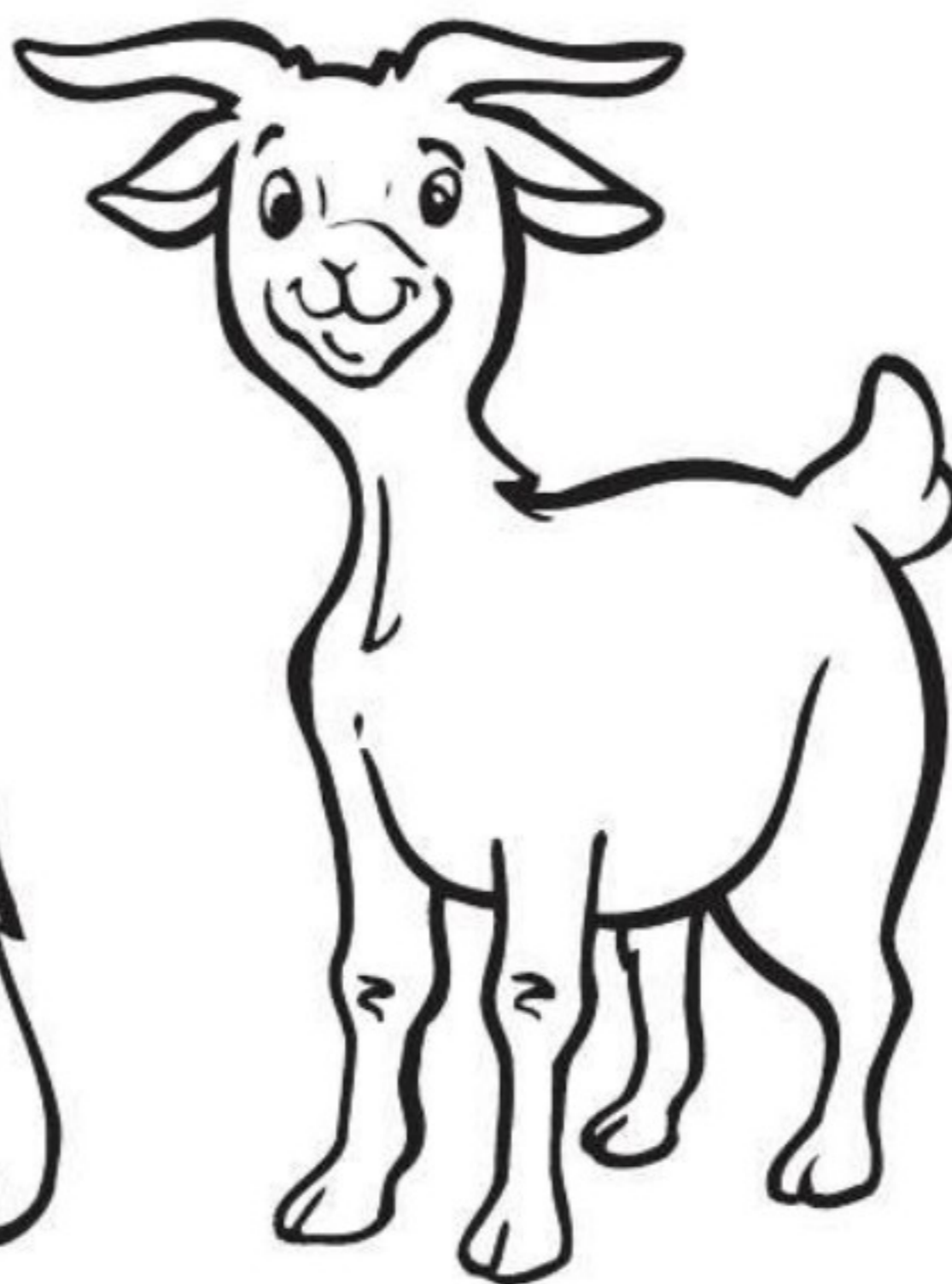
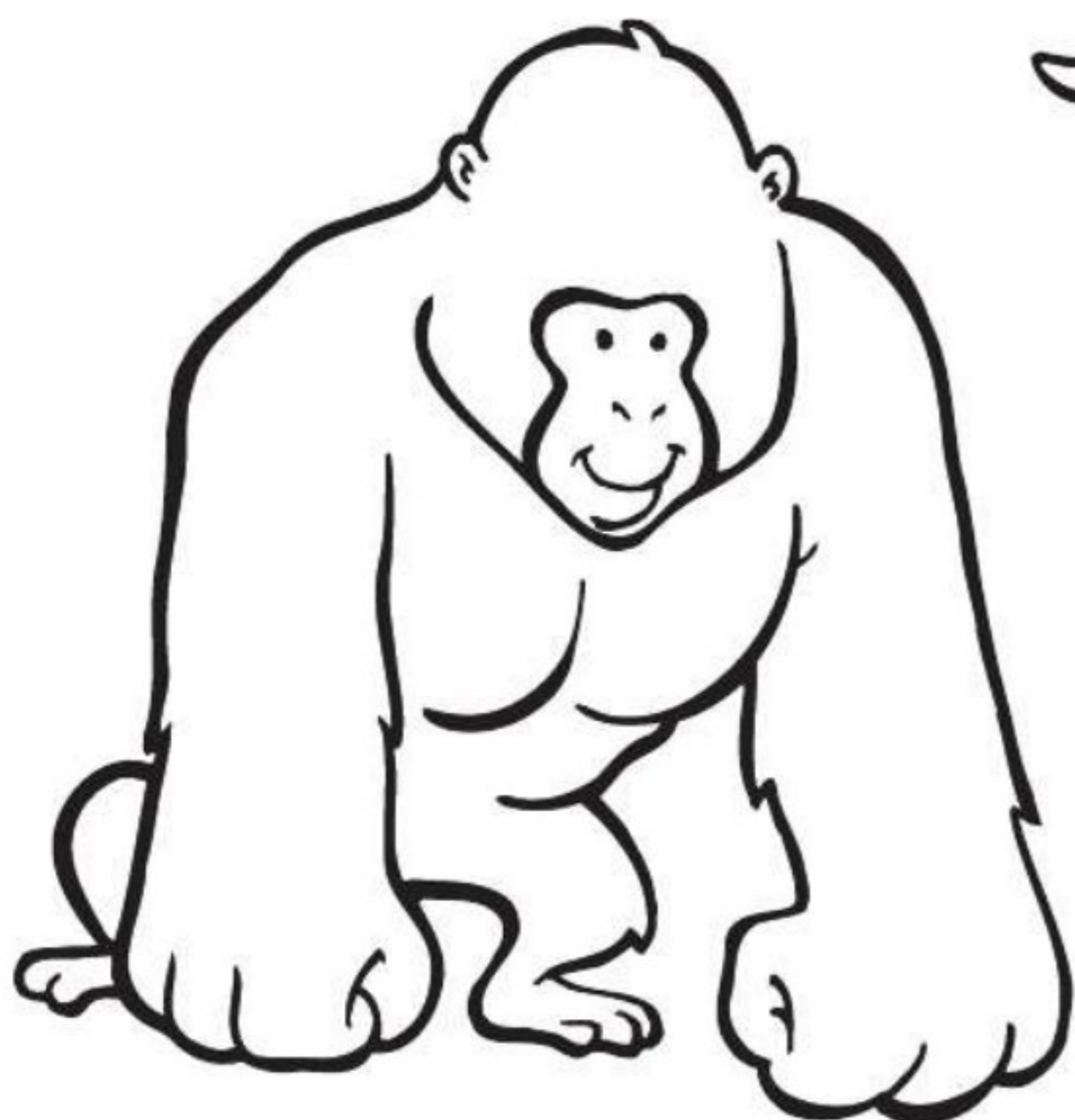



# Letter Gg

Look at each sign in the garden.

**Directions:** Trace  each **G** and **g**. Then, **color**  each sign with **G red** and **g blue**.

How many?

I have  
\_\_\_ Gs  
\_\_\_ gs



# Letter Gg

**Directions:** Circle  the **G** or **g** in these words:

goat

Gregory

gate

great

Gloria

gift

**Directions:** Color  the pictures that start with the sound of **Gg**.

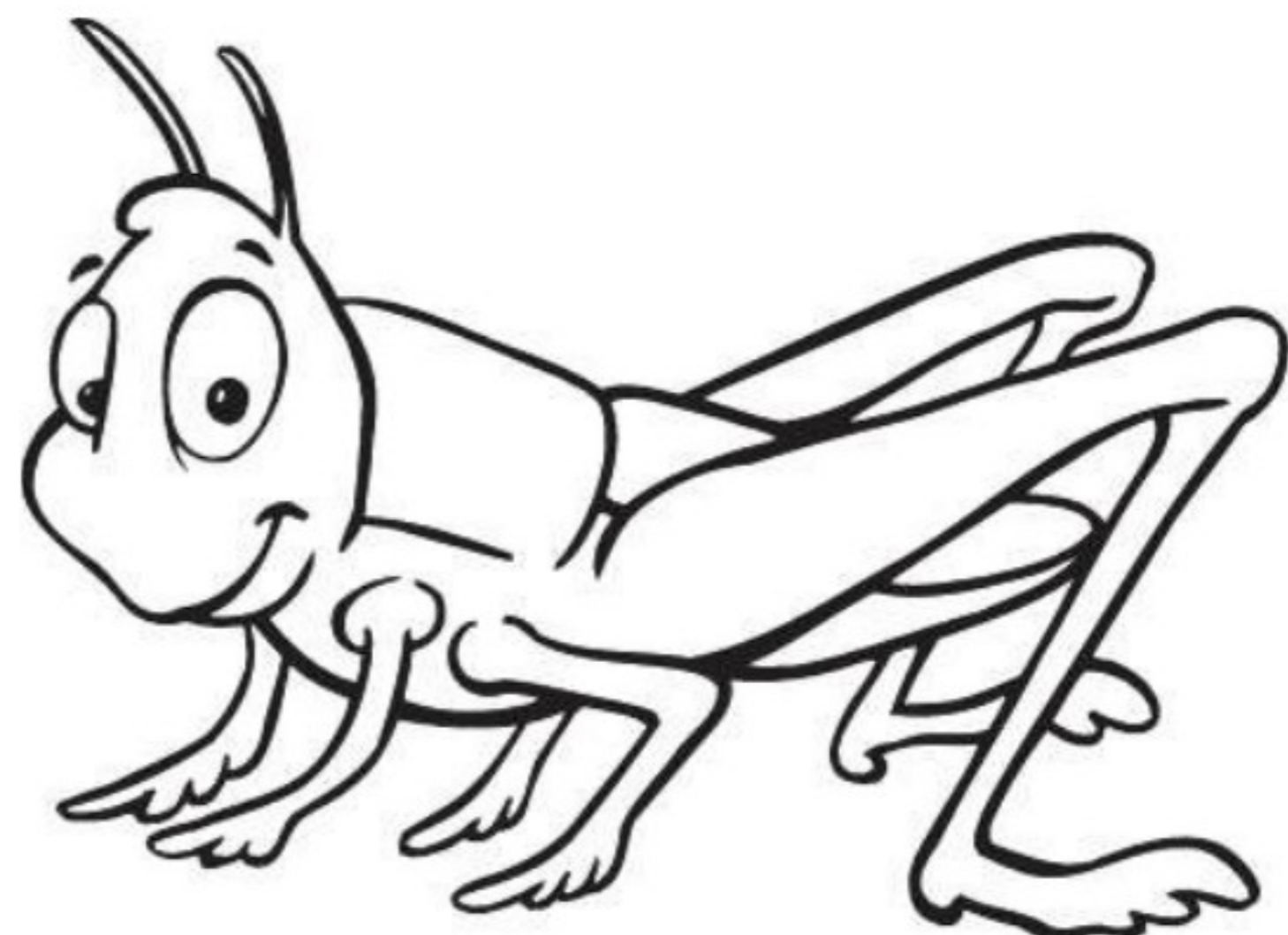
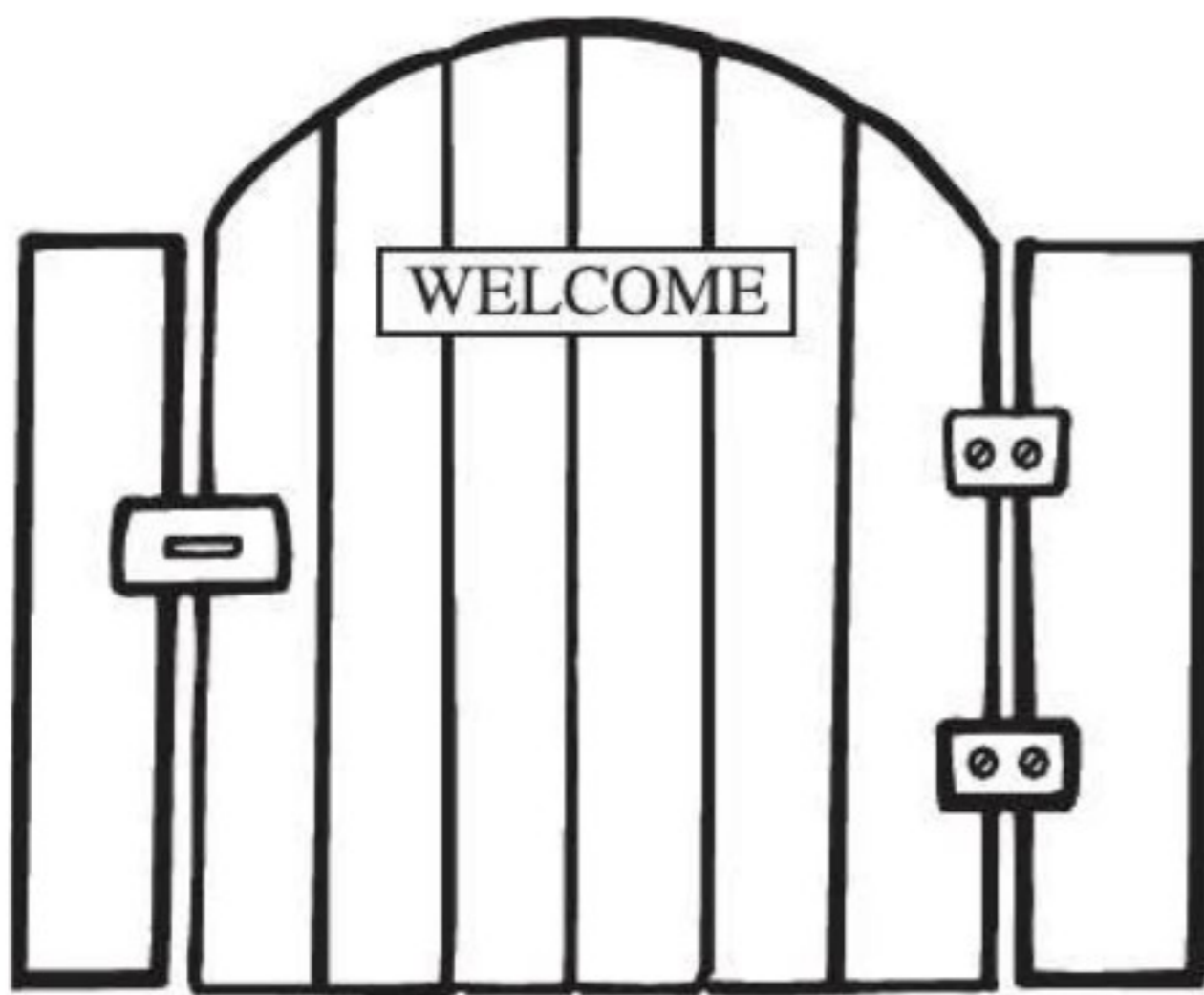







# Letter Gg

Which cars need gas?

**Directions:** Draw  a line from the gas pump  to each car that has a driver that begins with **G** or **g**. **Color**  the picture.

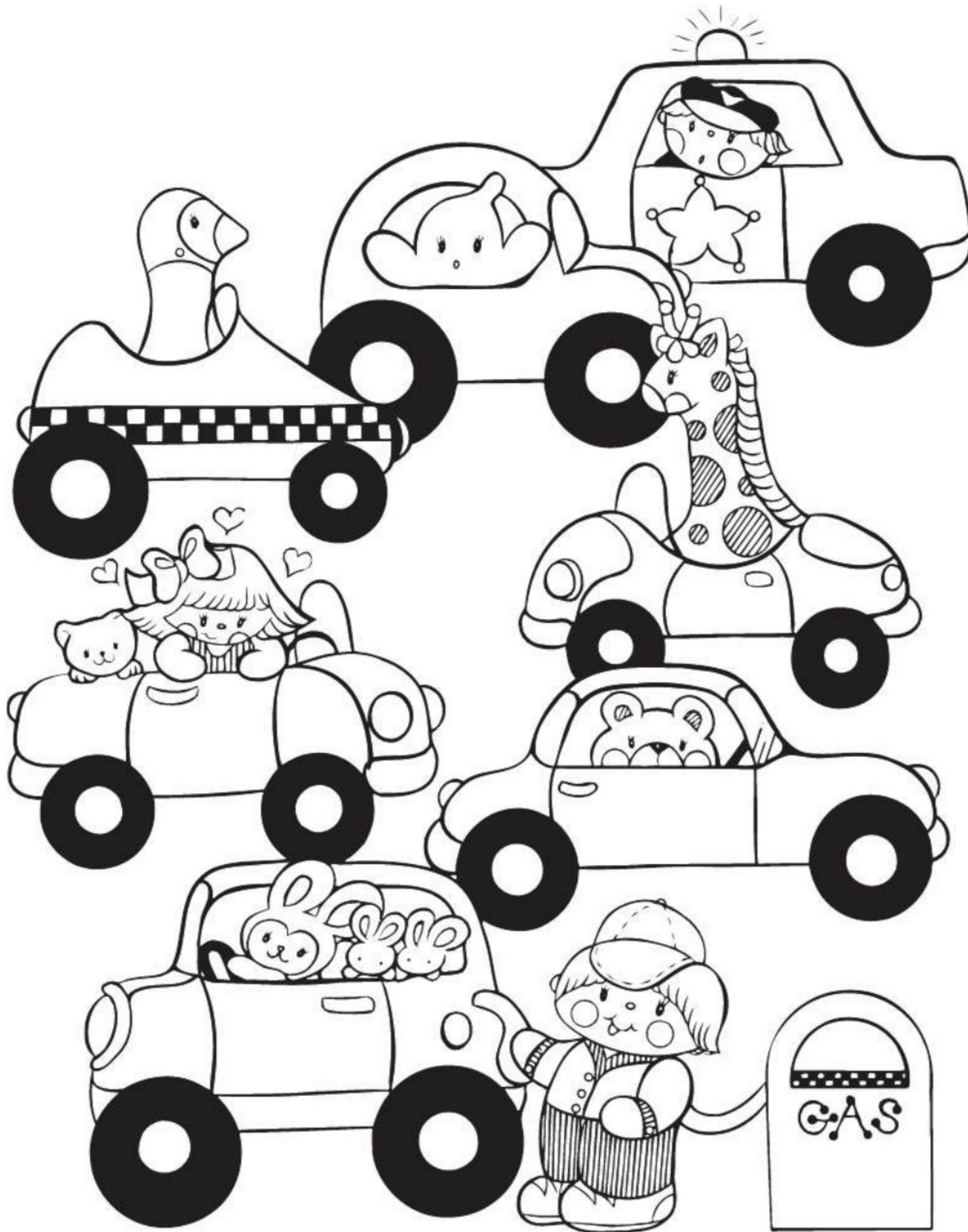



# Letter Hh



**Directions:** Trace and write  the letter Hh.



**Directions:** These pictures begin with the letter Hh.

Color  the pictures.

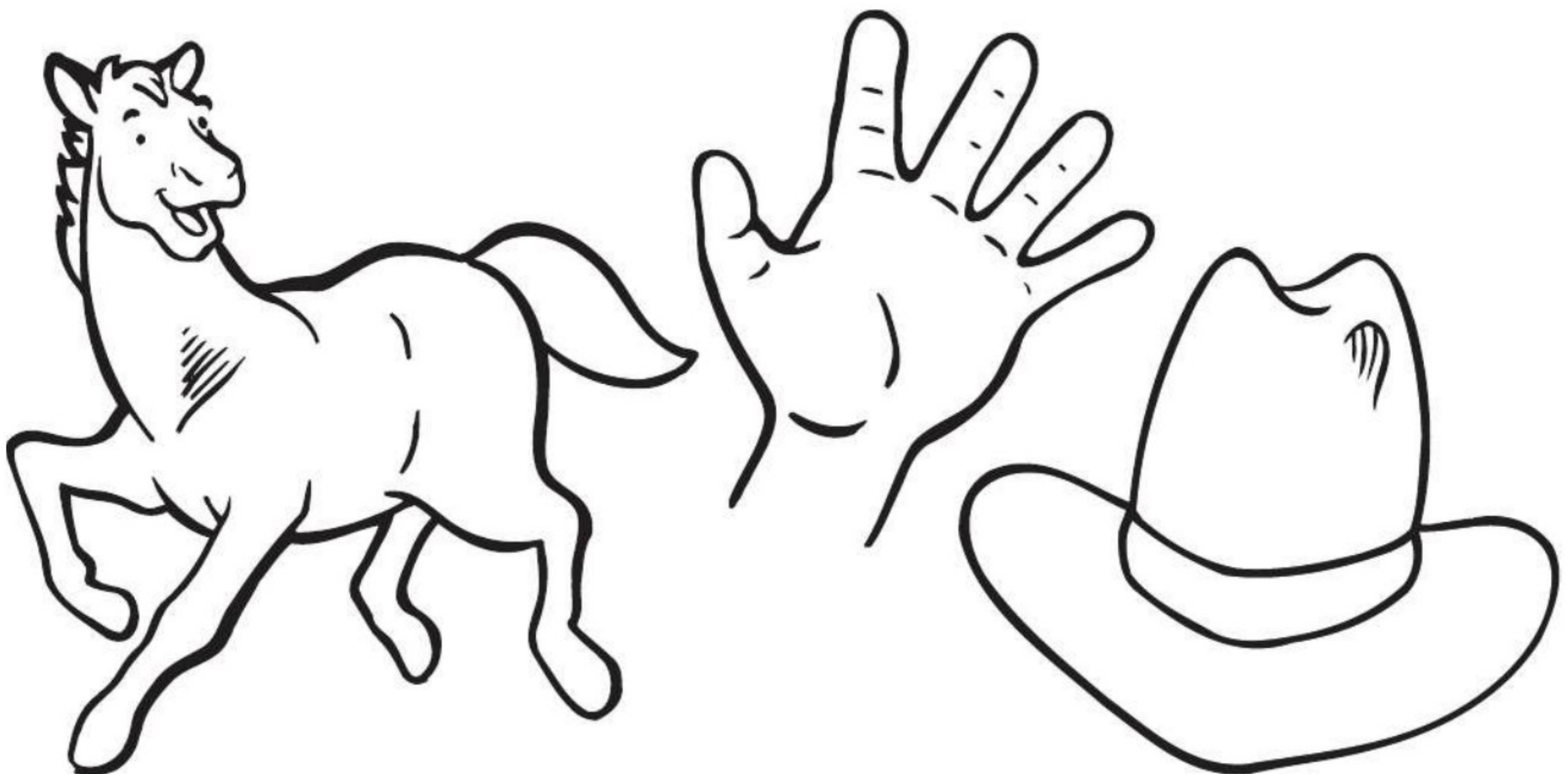



# Letter Hh

**Directions:** Color  the spaces with an **UPPERCASE H** red.

Color  the spaces with a **lowercase h** purple. What did you find?

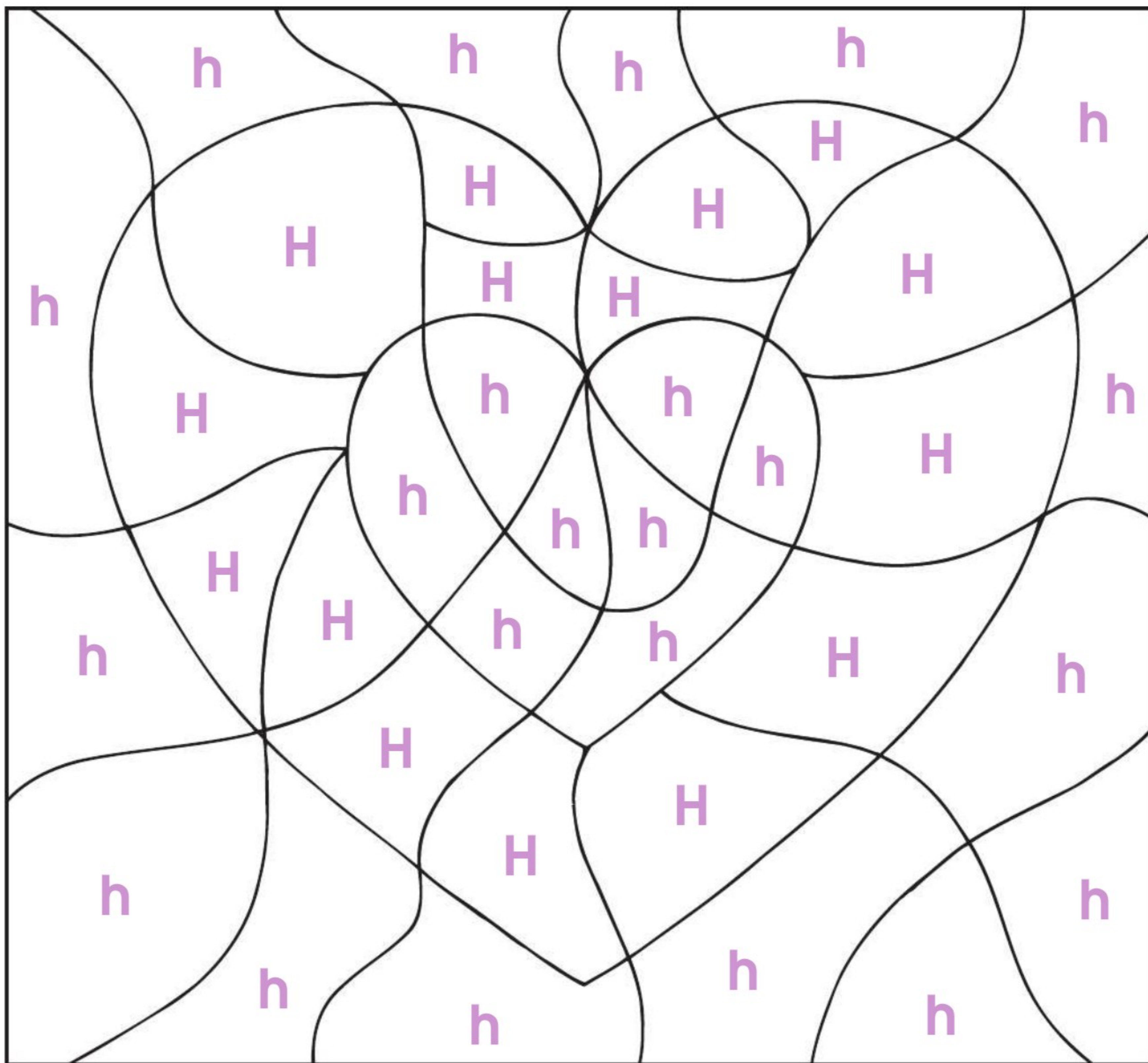



# Letter Hh

**Directions:** Circle  the **H** or **h** in these words:

Heather

hose

house

Henry

horse

hand

**Directions:** Color  the pictures that start with the sound of **Hh**.

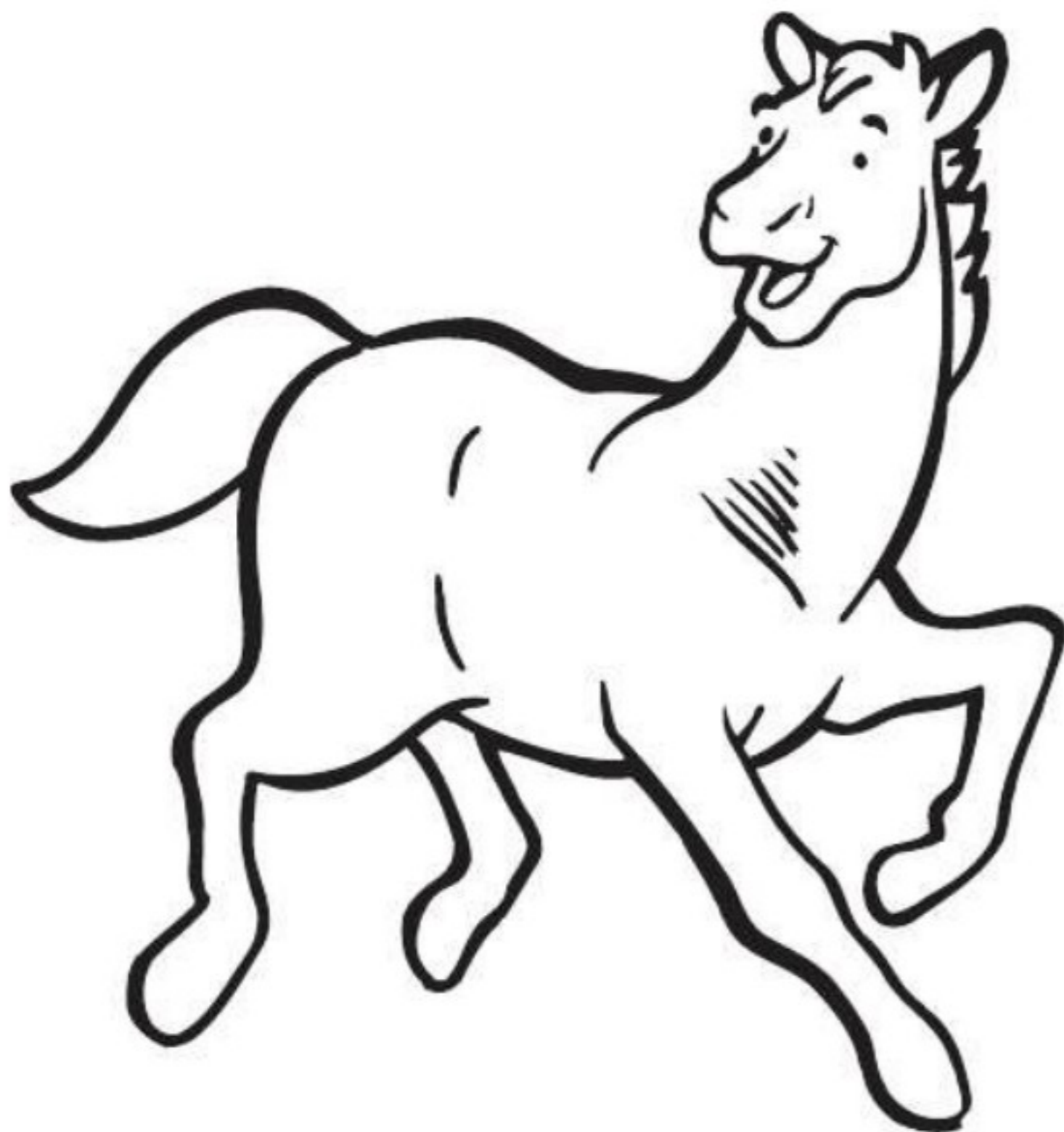
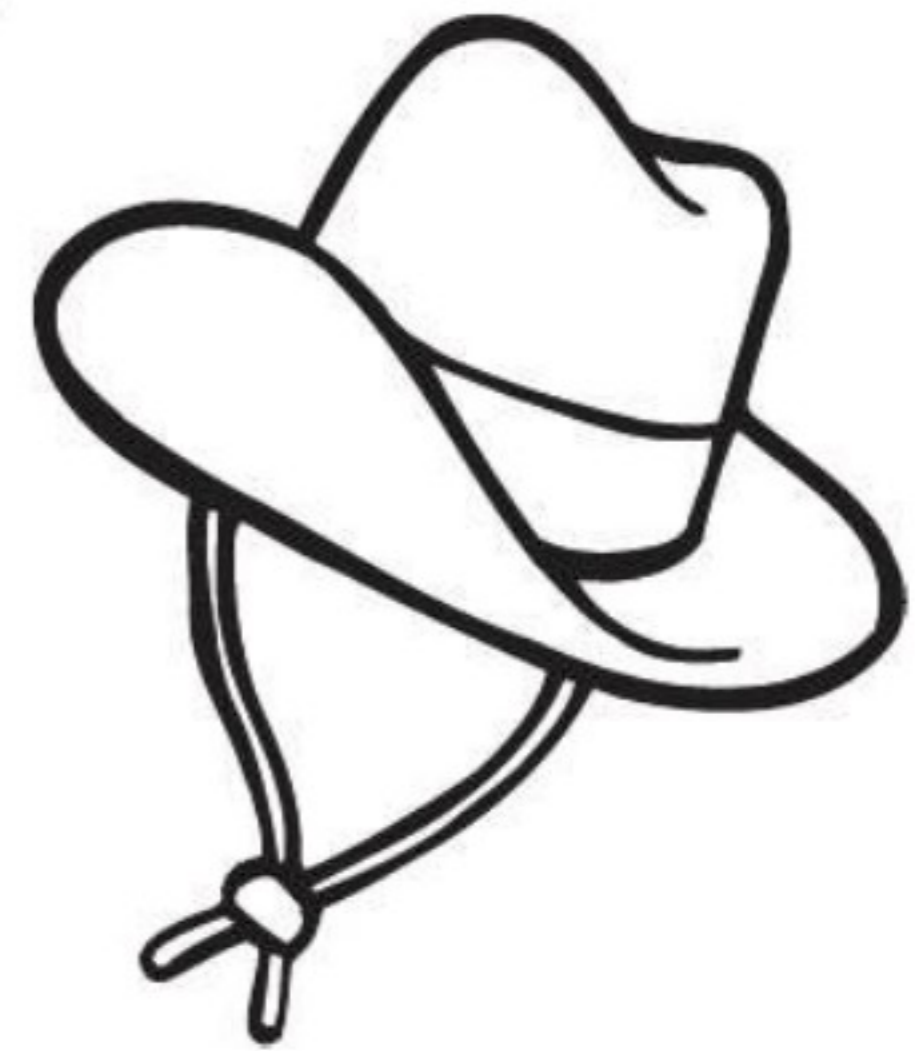
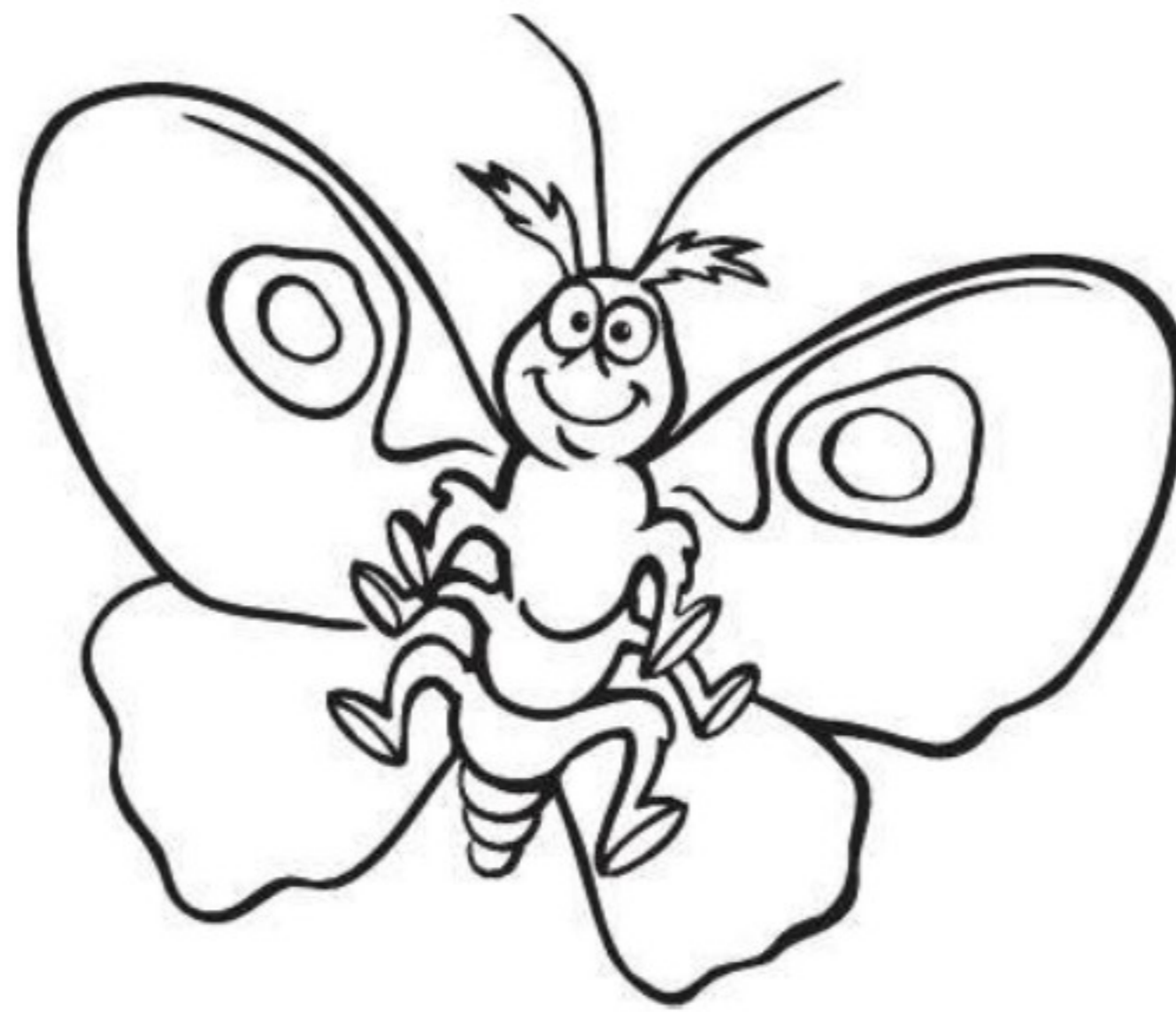



# Letter Hh

These words start with **H** or **h**.

**Directions:** Write  a lowercase **h** on each line.

**Color**  the pictures.

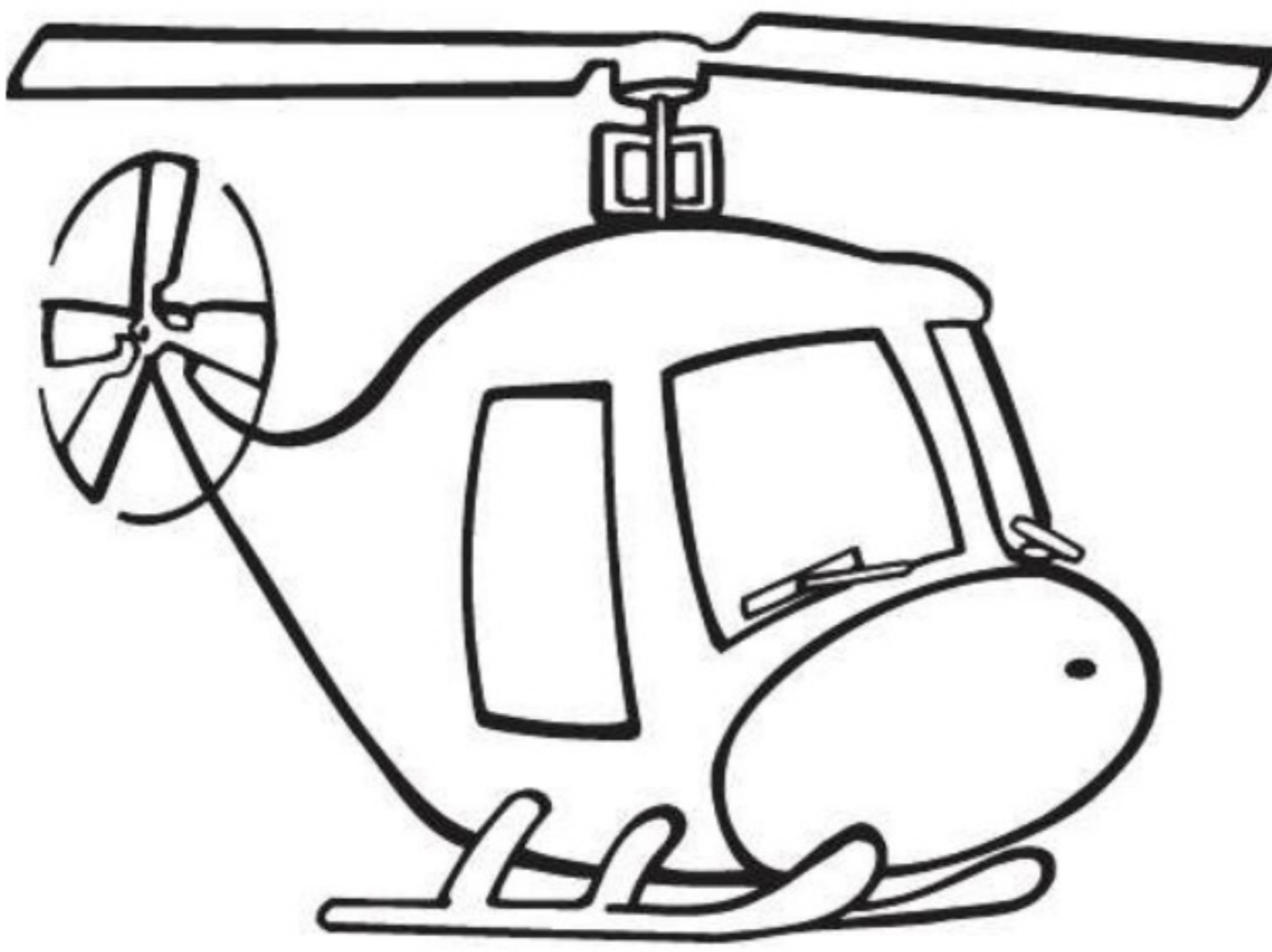

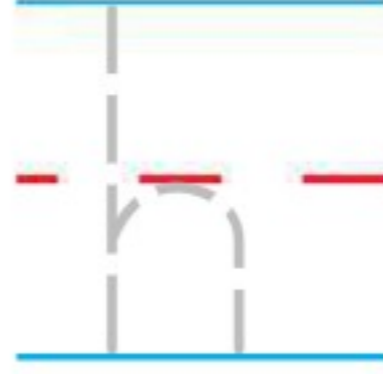
**H** is for  helicopter.

**H** is for  orn.

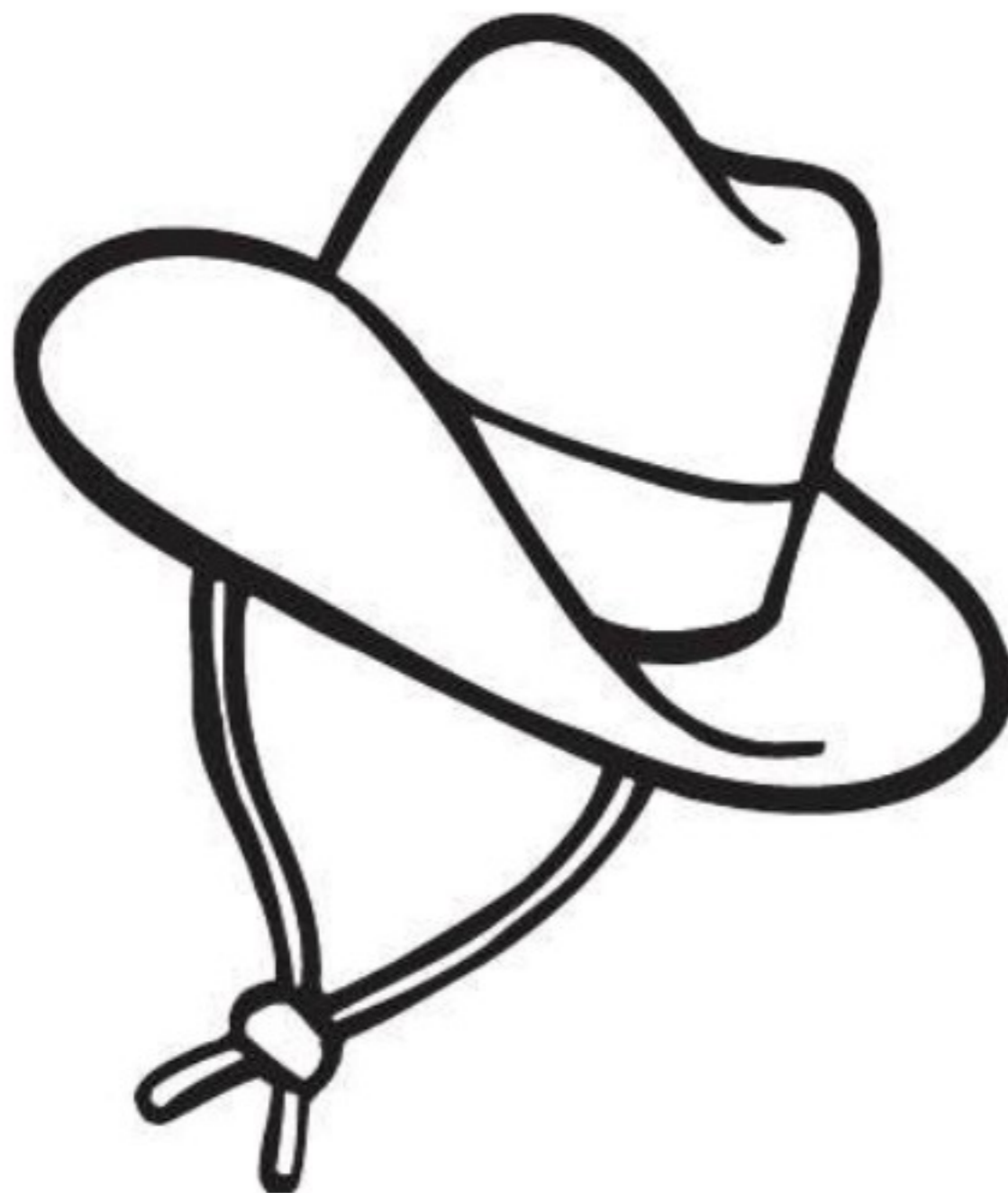

**H** is for  at.

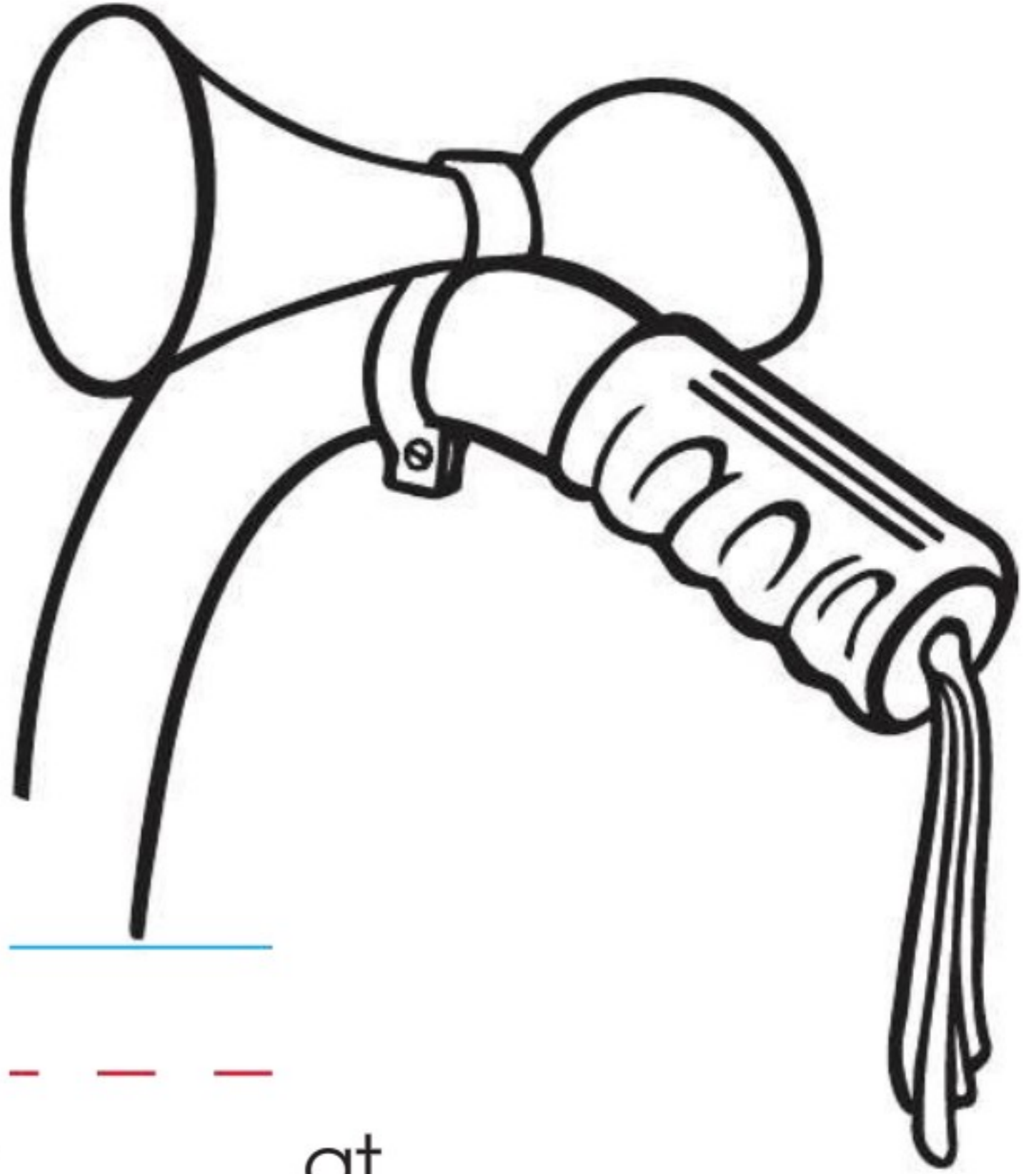



# Letter Ii

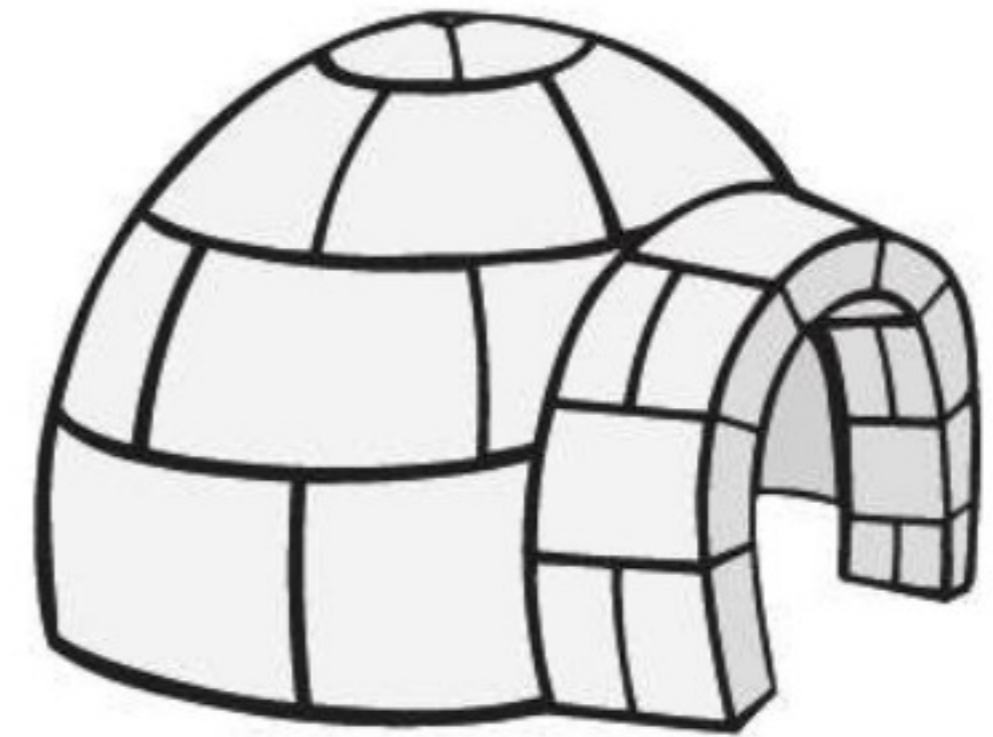

**Directions:** Trace and write  the letter **Ii**.

UPPERCASE



lowercase

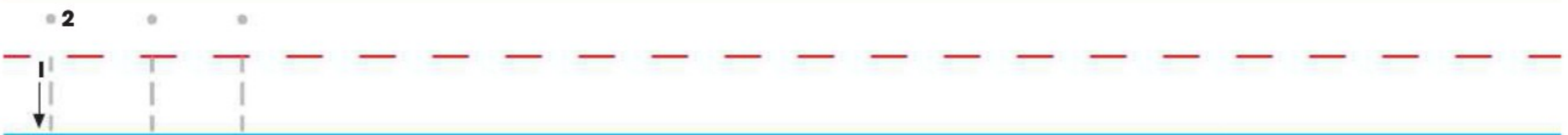

**Directions:** These pictures begin with the letter **Ii**.

**Color**  the pictures.





# Letter Ii

Help read the 's smoke signals.

**Directions:** Color  each **I** red. Color each **i** blue.

Color  the rest of the picture!

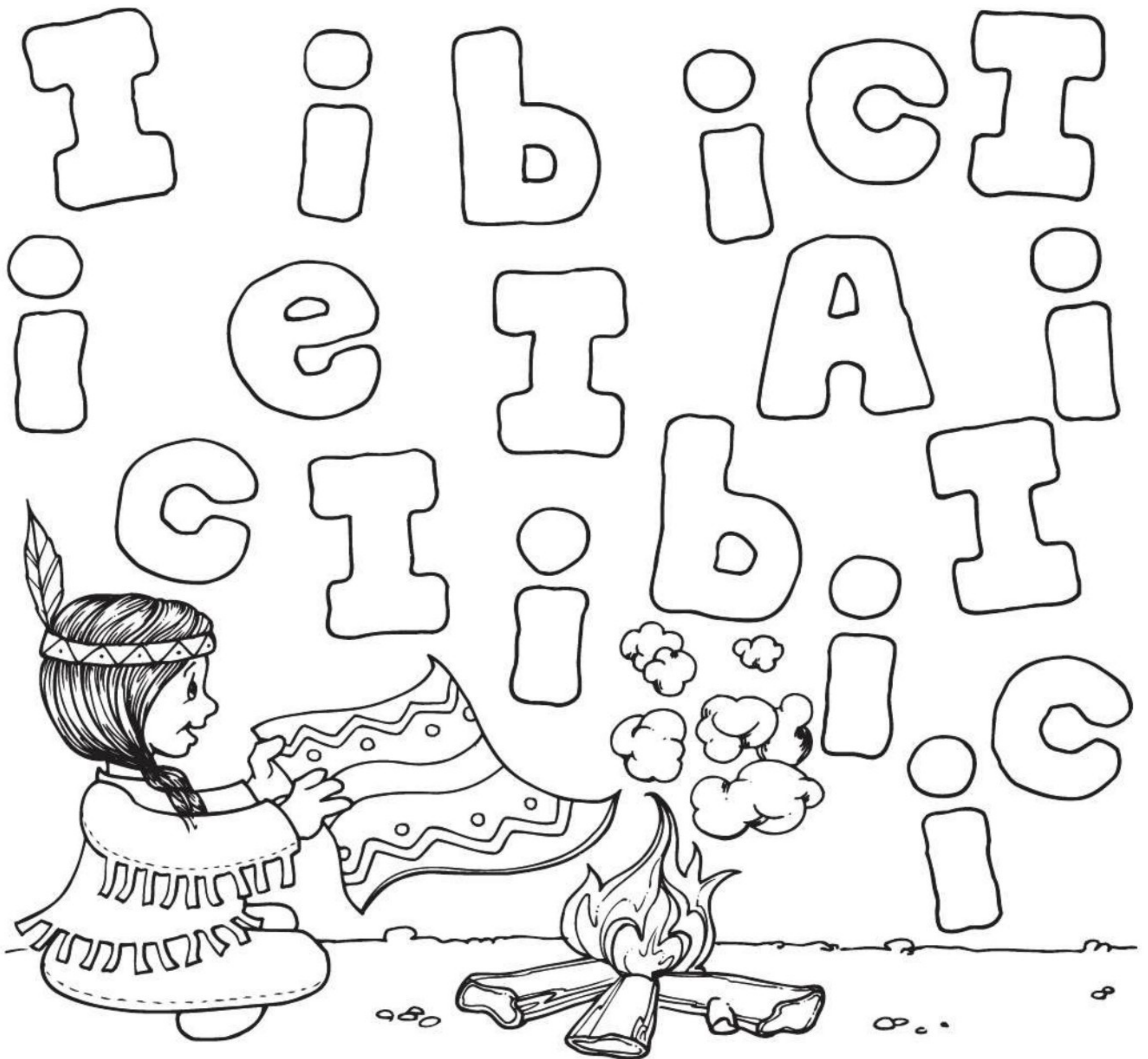



# Letter Ii

**Directions:** Circle  the **I** or **i** in these words:

is

ice cream

igloo

Ivan

icing

Indian

The letter **Ii** can have more than one sound.

**Directions:** Color  the pictures that start with the sound of **Ii**.

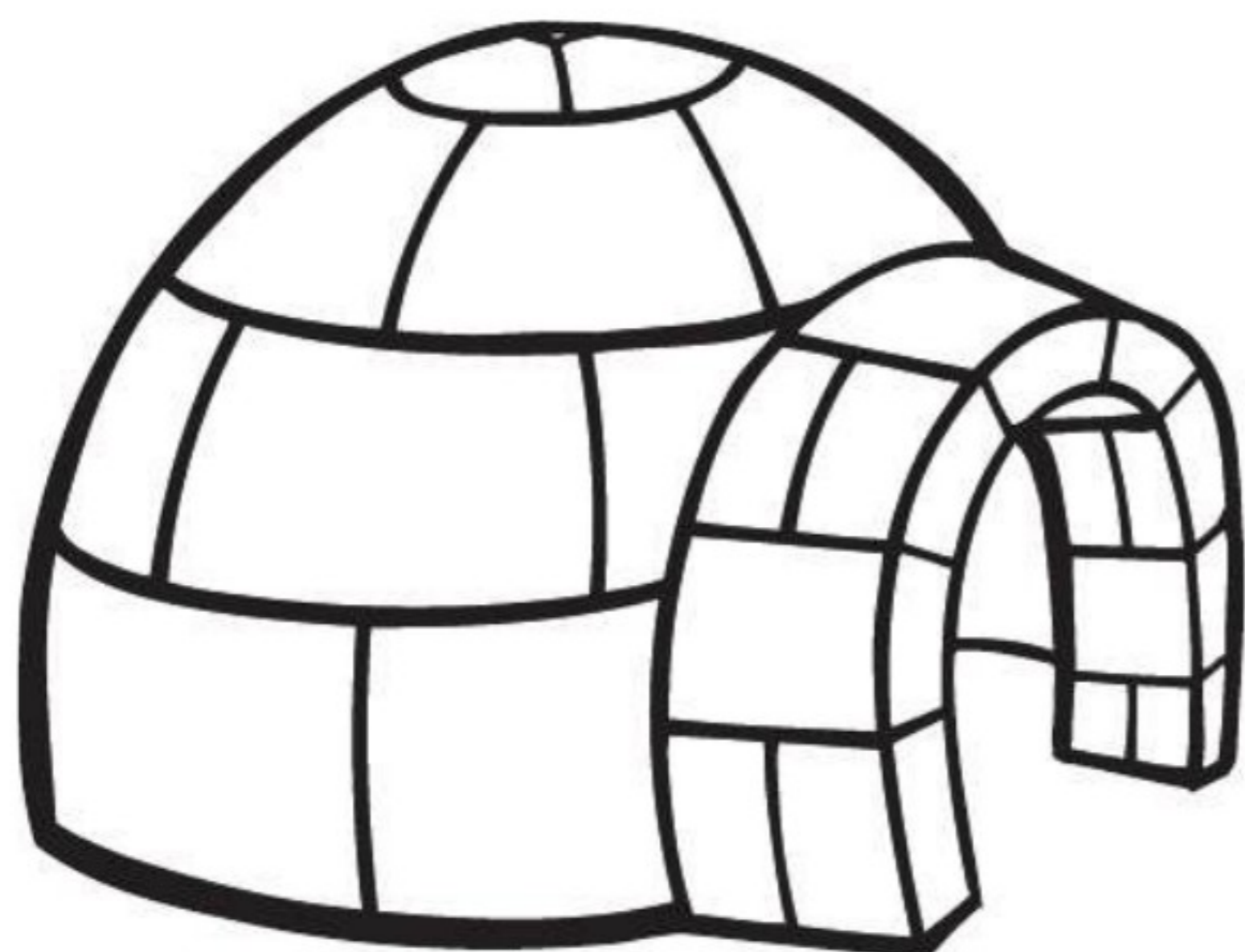





# Letter Ii

These words start with **I** or **i**.

**Directions:** Write  a lowercase **i** on each line.

**Color**  the pictures.

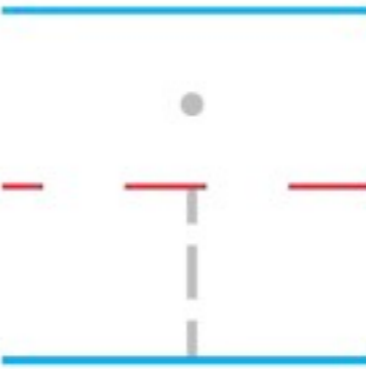

I is for  nsects.



I is for  gloo.

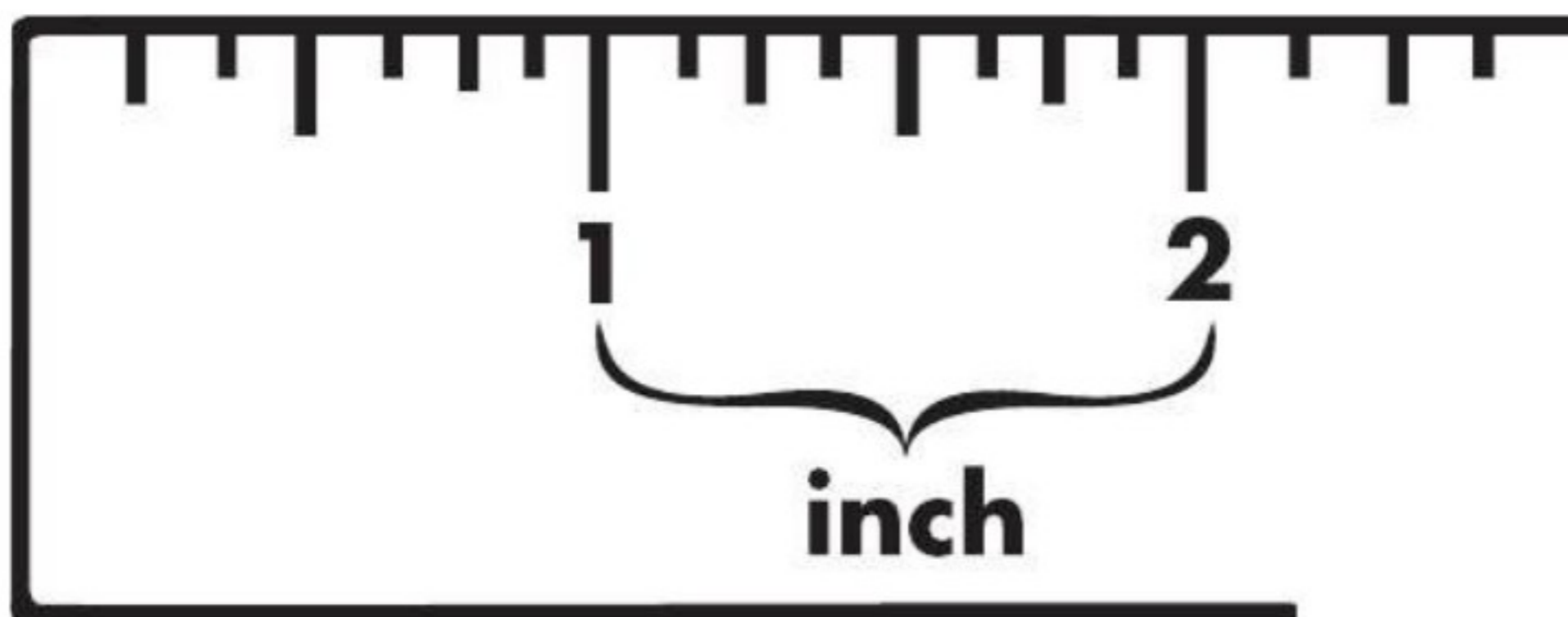
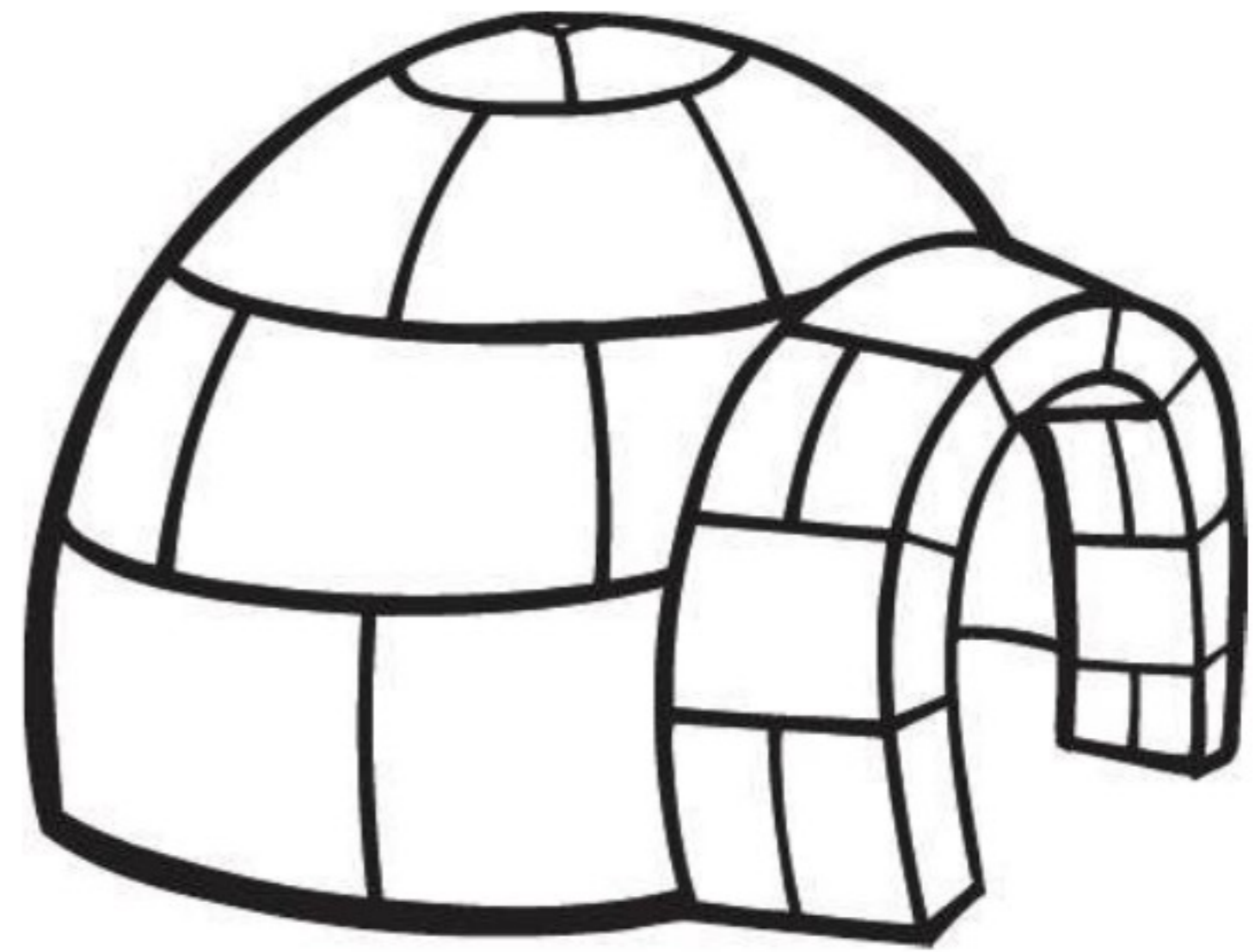

I is for  nch.



# Letter Jj



**Directions:** Trace and write  the letter Jj.

UPPERCASE



lowercase



**Directions:** These pictures begin with the letter Jj.

Color  the pictures.

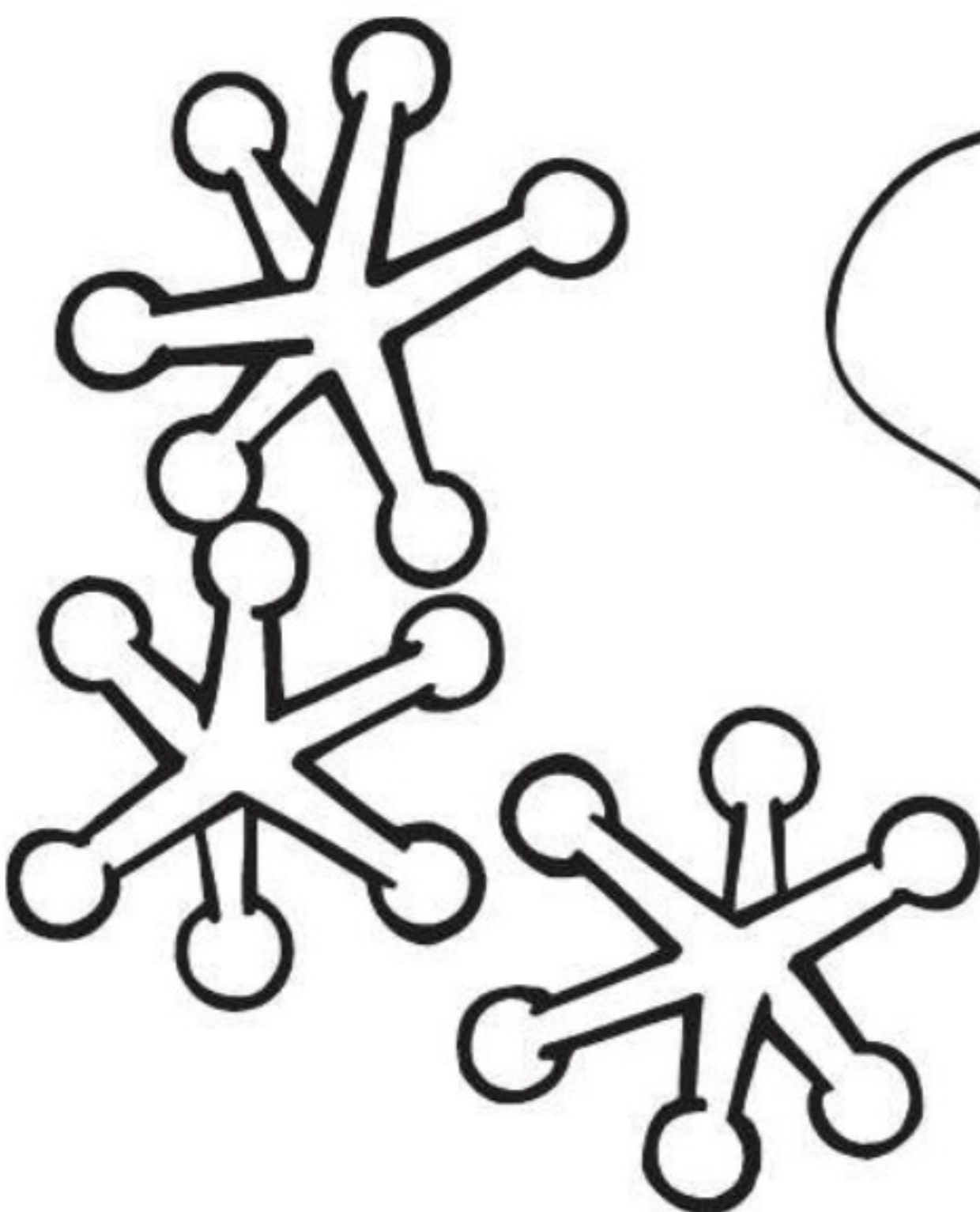



# Letter Jj

Can you find each hidden J and j in the picture?

**Directions:** Color  each J **red**. Color  each j **green**.

Then, **color**  the rest of the picture!

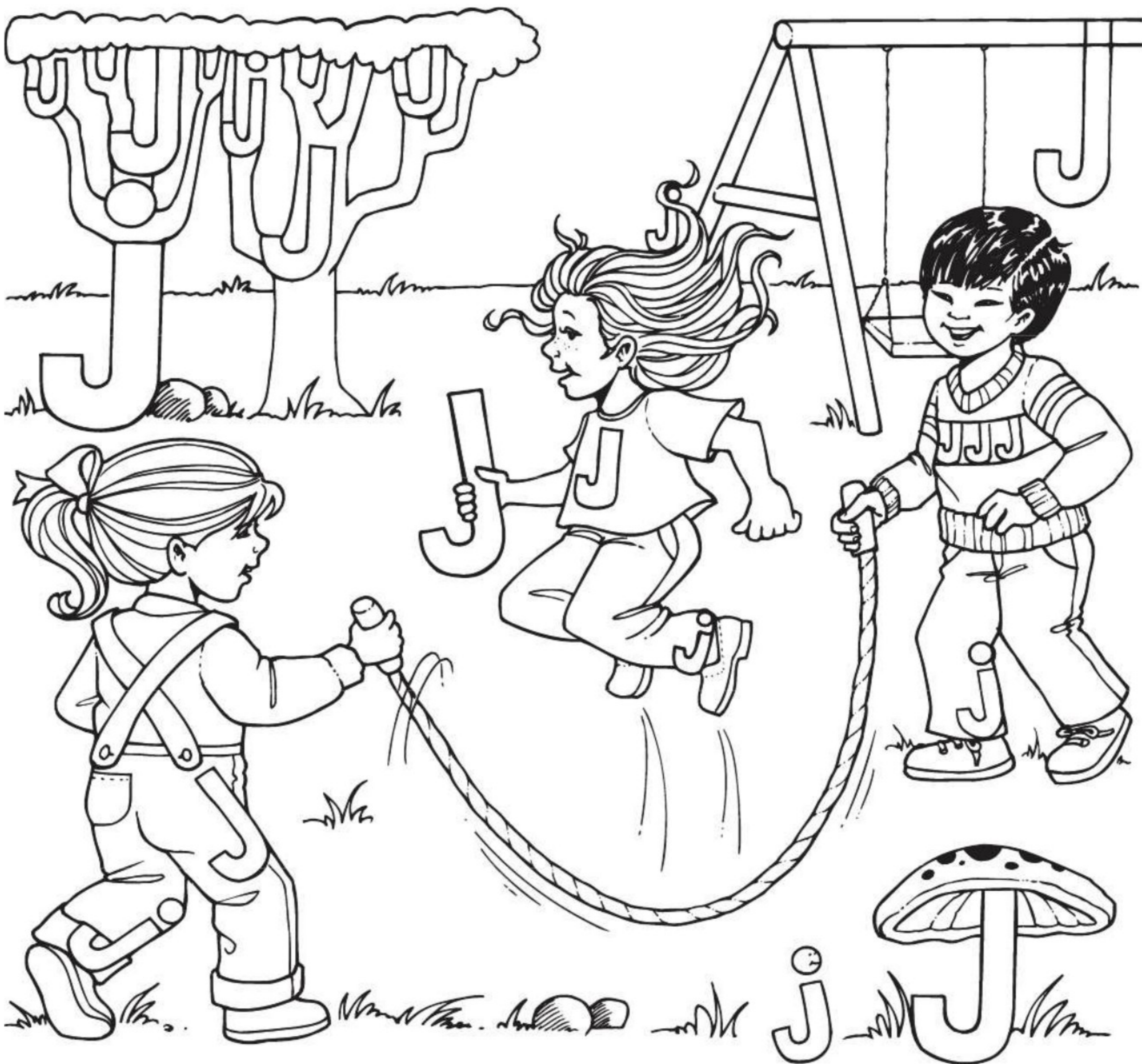



# Letter Jj

**Directions:** Circle  the **J** or **j** in these words:

**Jamal**

**jump**

**Jennifer**

**jug**

**jar**

**joke**

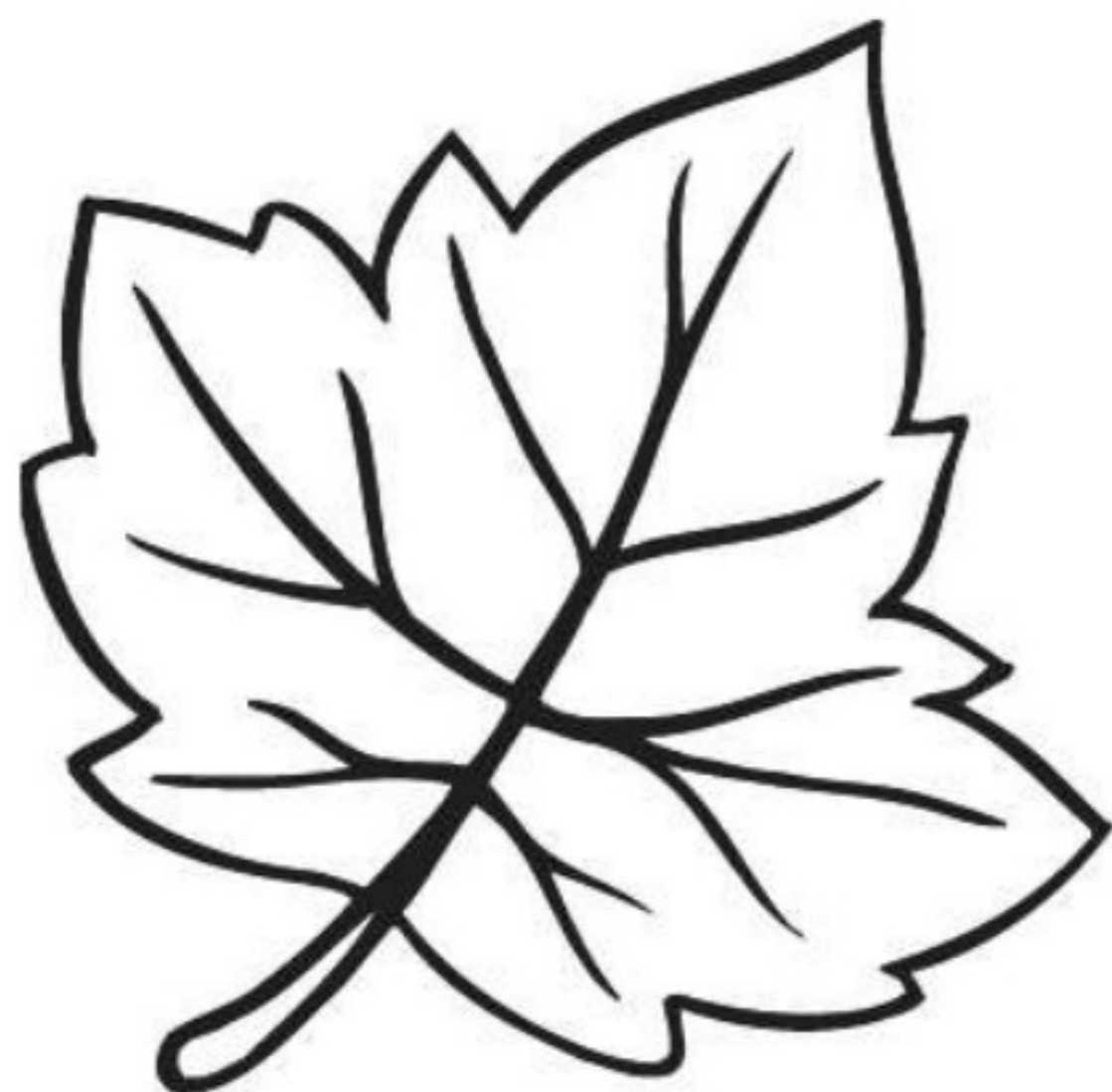
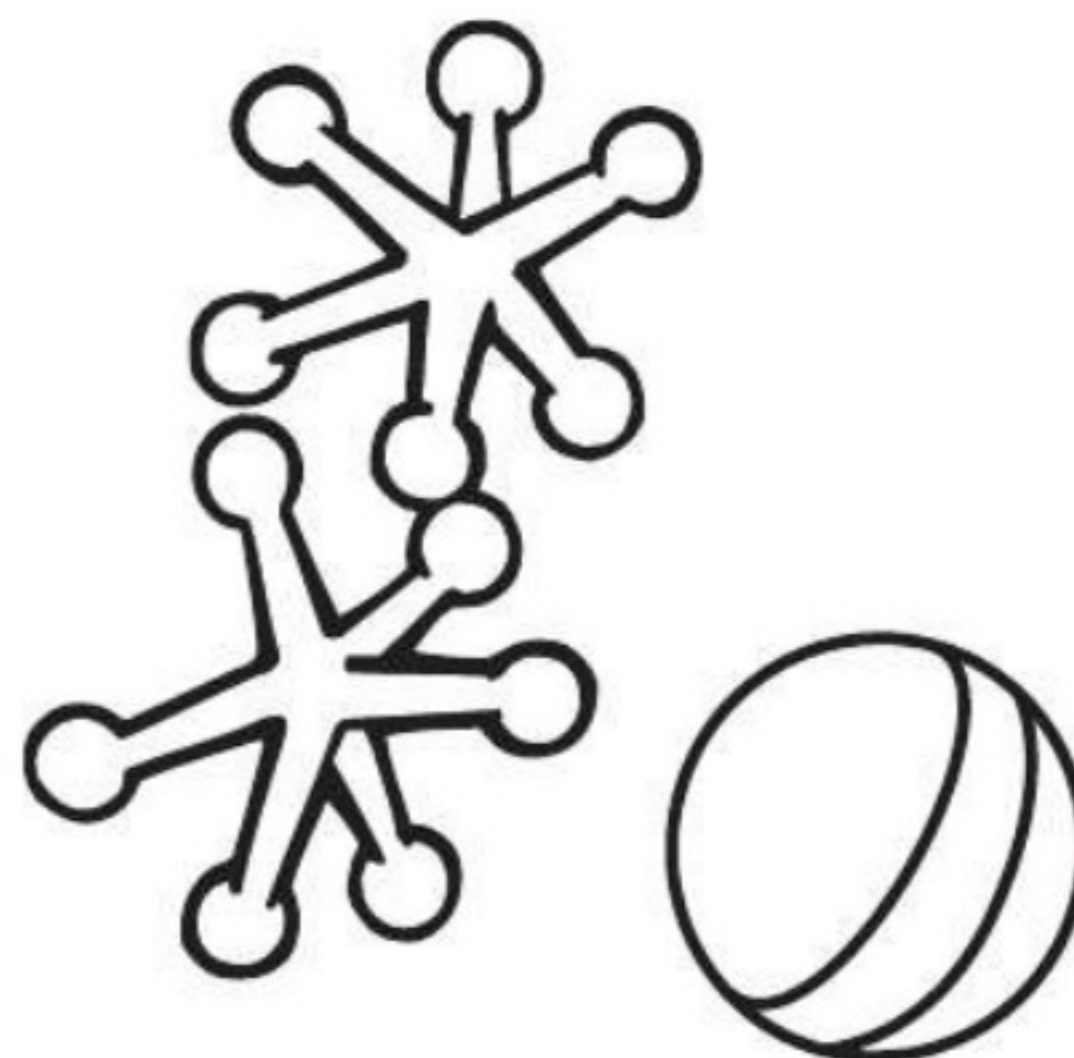

**Directions:** Color  the pictures that start with the sound of **Jj**.





# Letter Jj

Jake Jaguar likes jellybeans!

**Directions:** Draw  a line from Jake Jaguar to each jellybean that has a picture that begins with the sound of **Jj**. **Color**  the pictures with bright colors!





# Letter Kk

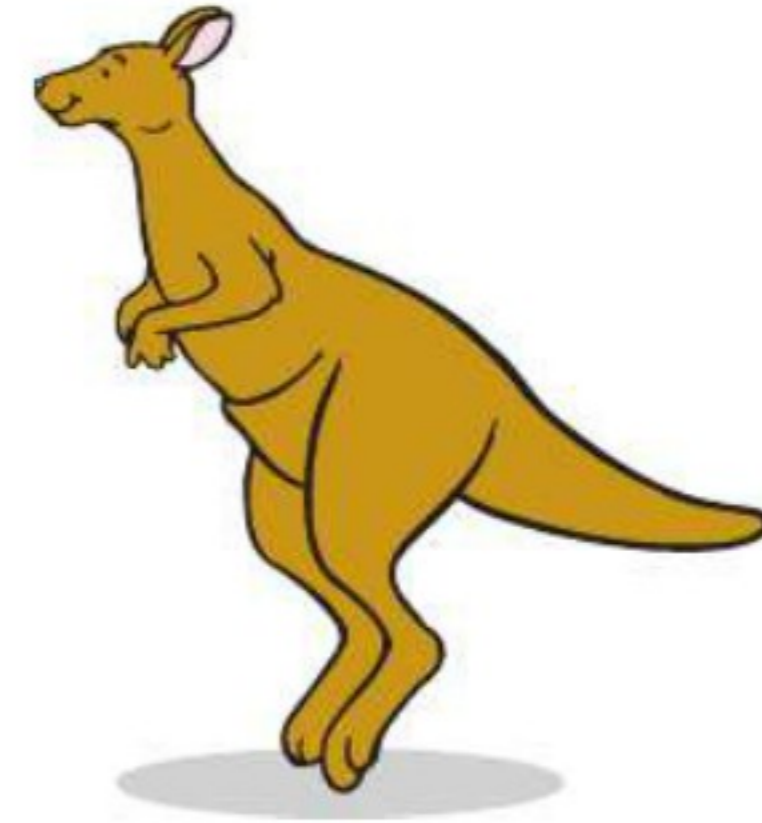

**Directions:** Trace and write  the letter **Kk**.

UPPERCASE



lowercase



**Directions:** These pictures begin with the letter **Kk**.

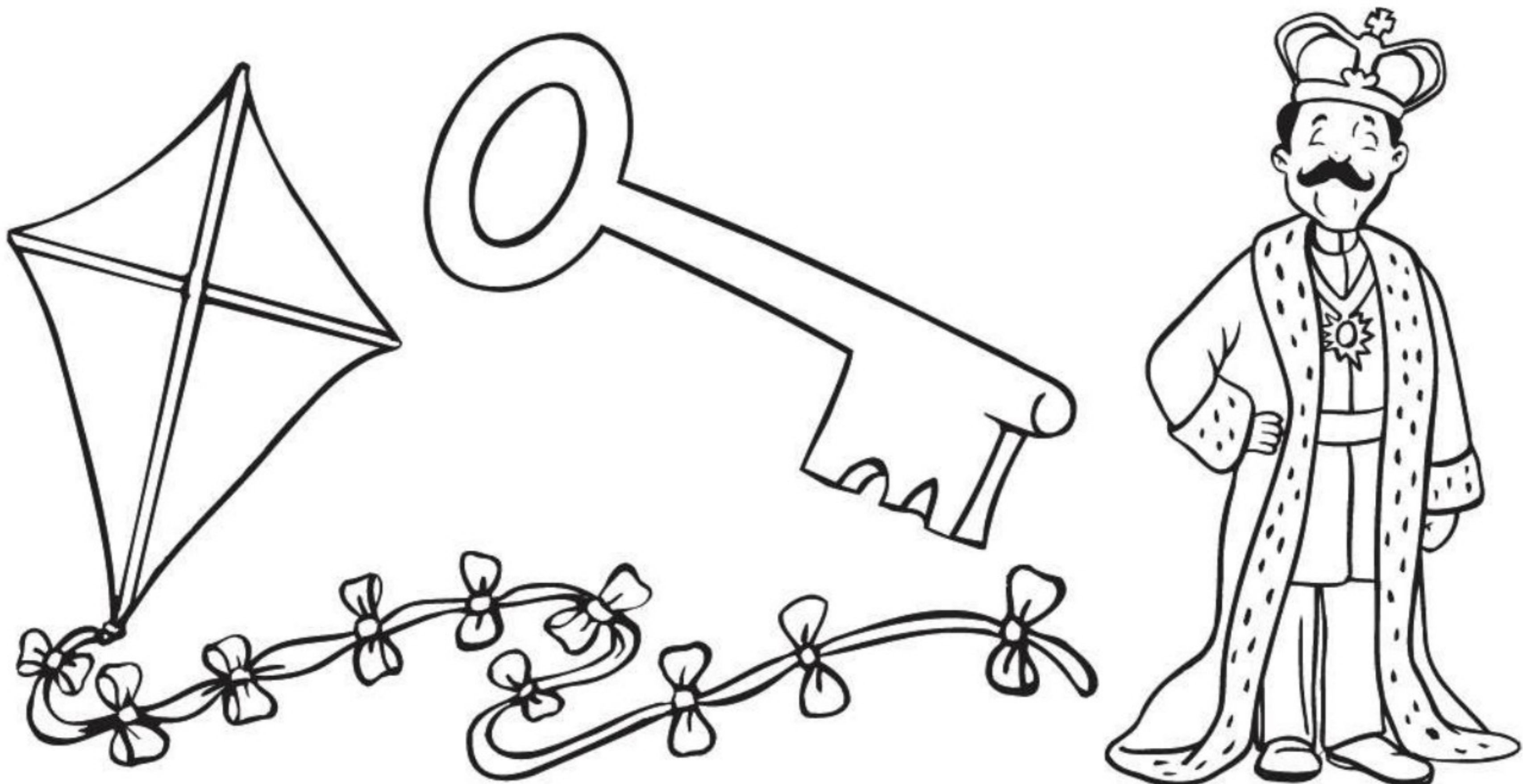

**Color**  the pictures.





# Letter Kk

Look at each letter on the kites.

**Directions:** Match the letters on the sections of the kites and **color**  them the correct colors. Then, **color**  the rest of the picture.

K = blue  
k = yellow

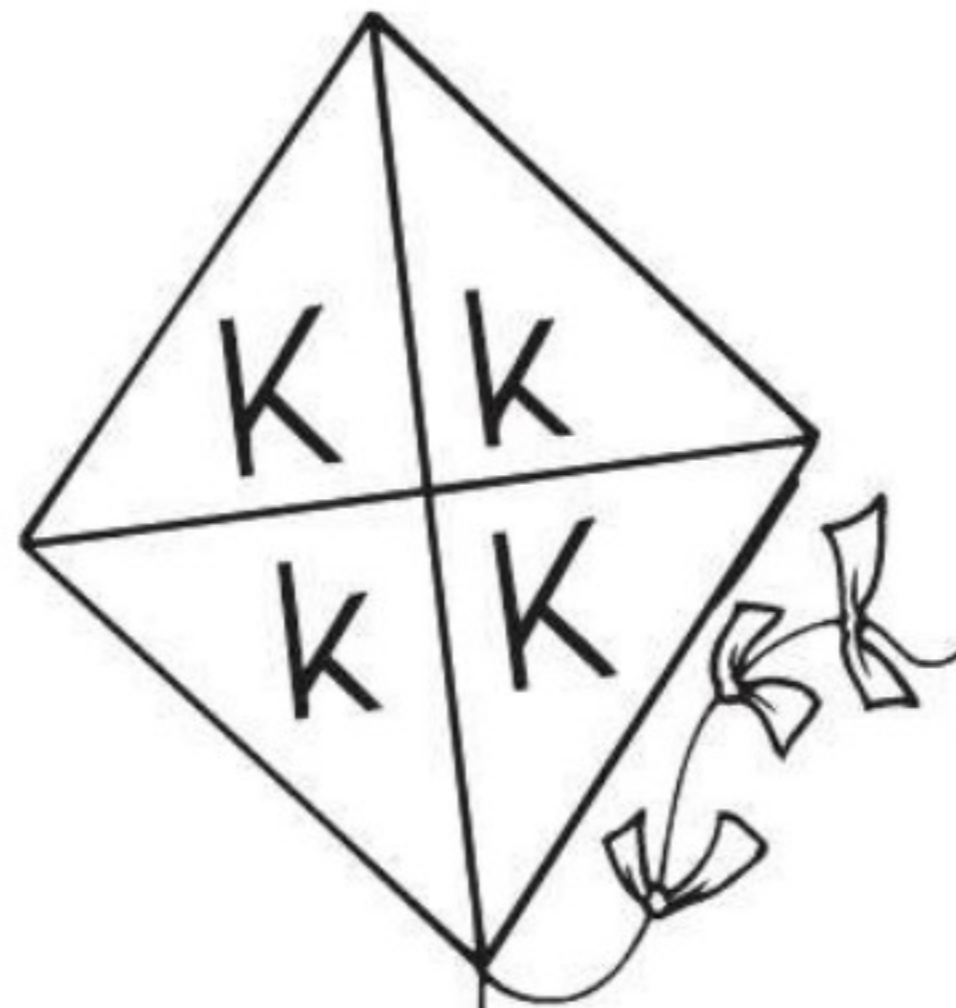

K = yellow  
k = red

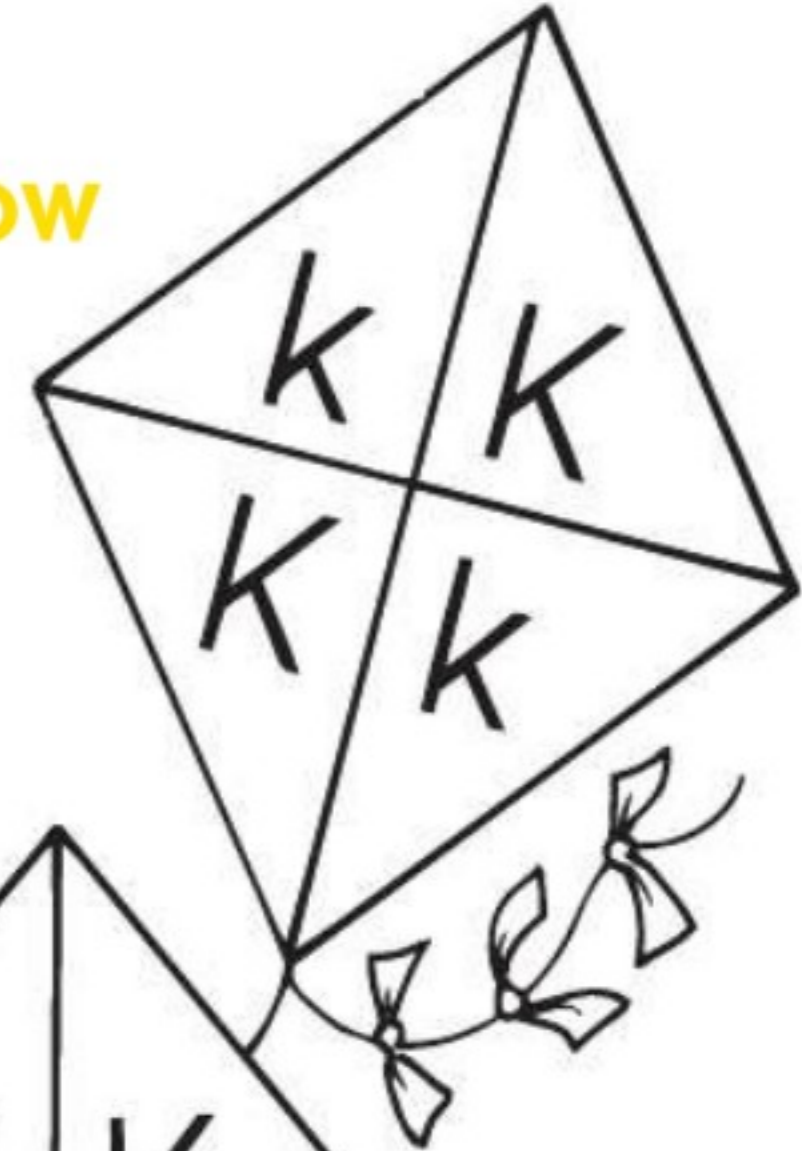

K = orange  
k = purple

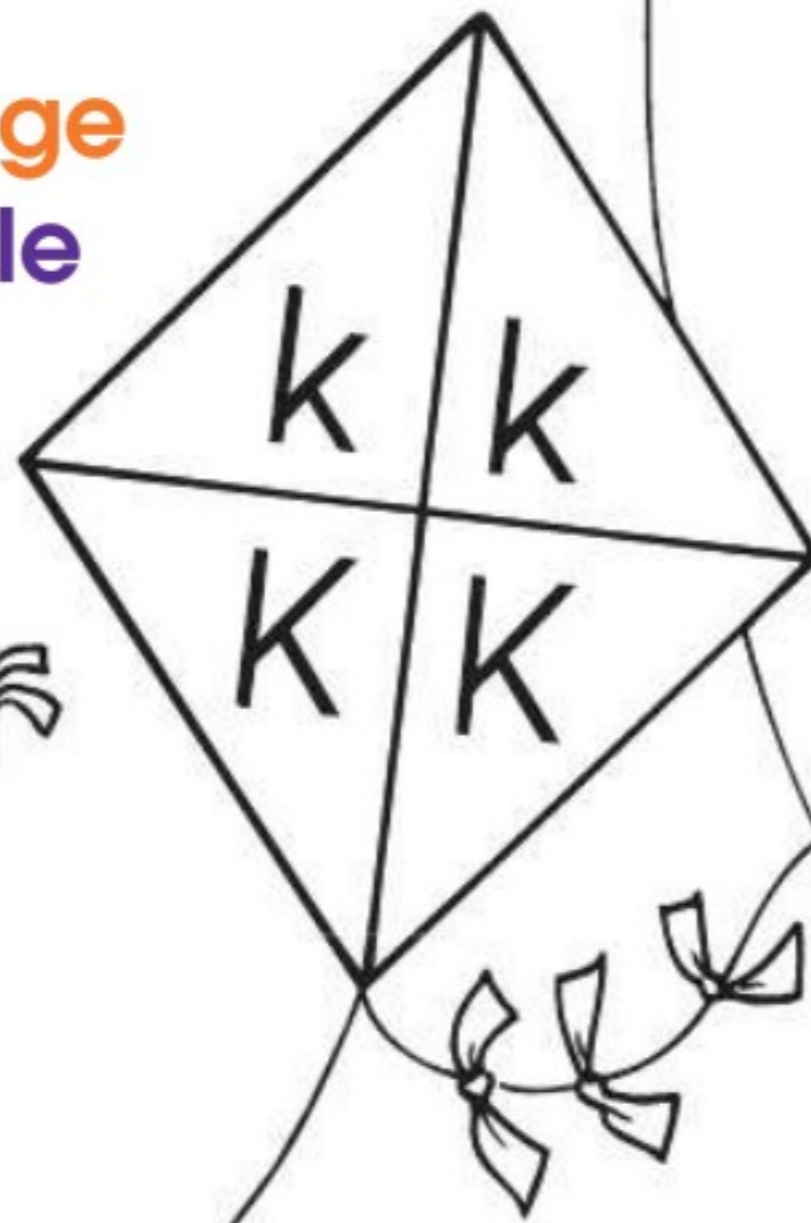

K = green  
k = red

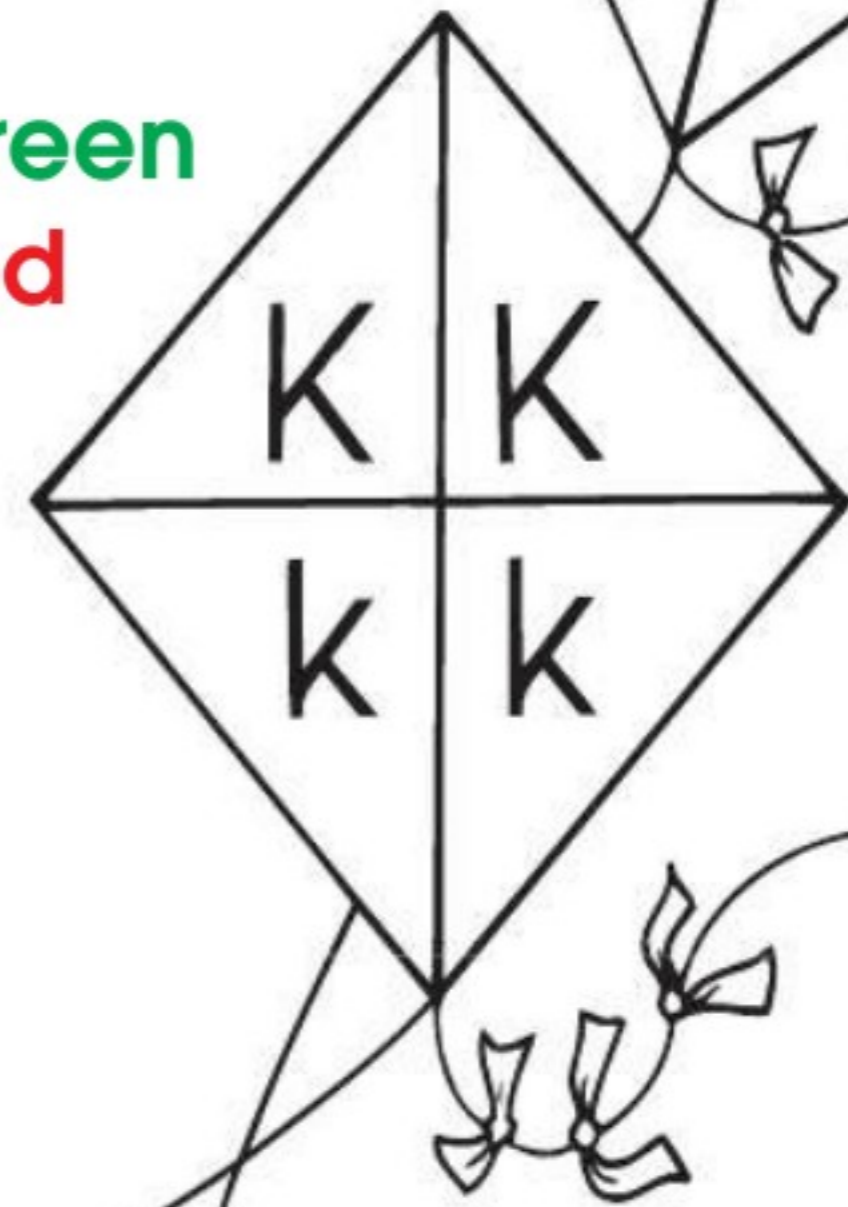



# Letter Kk

**Directions:** Circle  the **K** or **k** in these words:

key

kite

kangaroo

Kim

karate

Kelly

**Directions:** Color  the pictures that start with the sound of **Kk**.

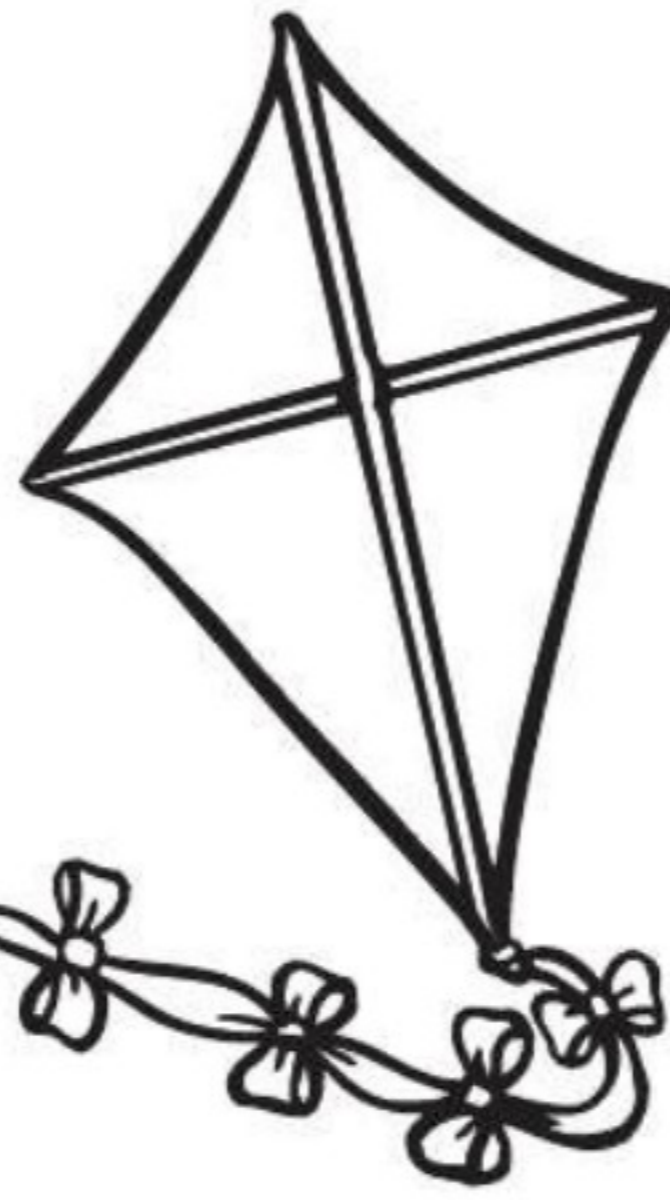
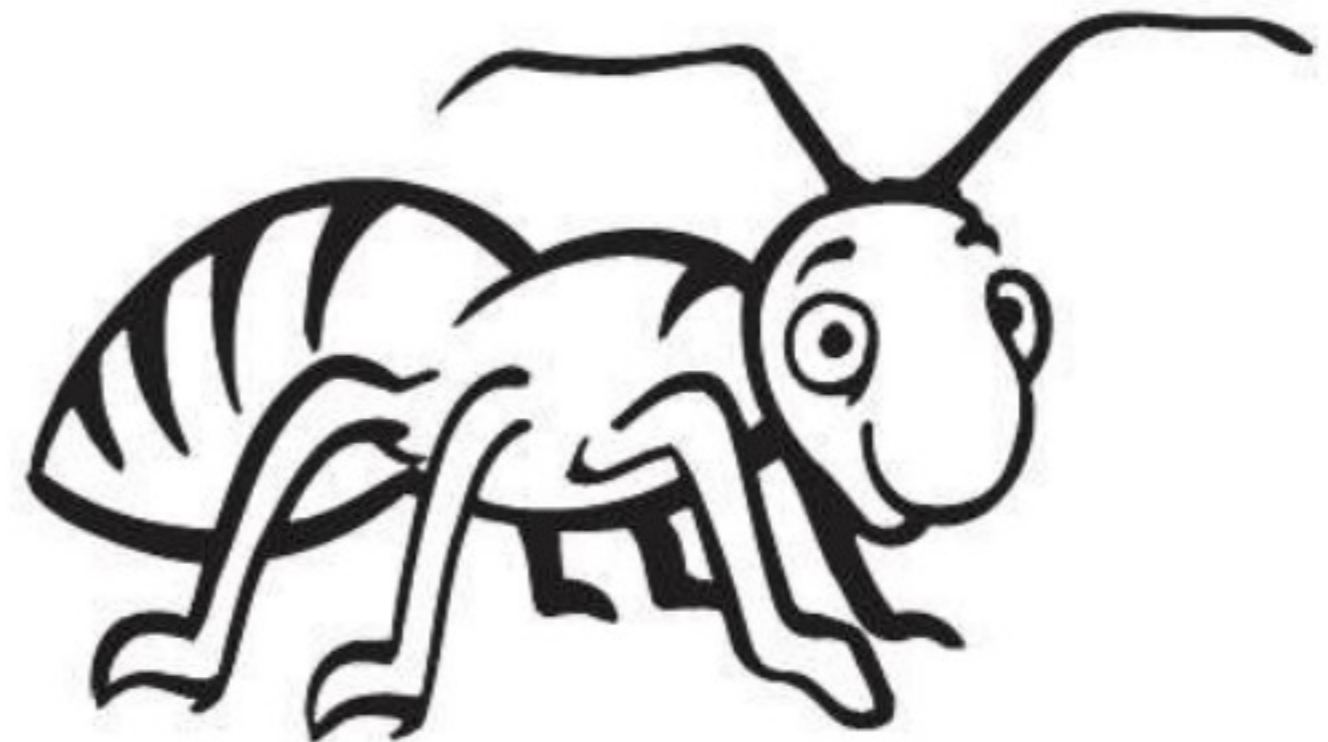
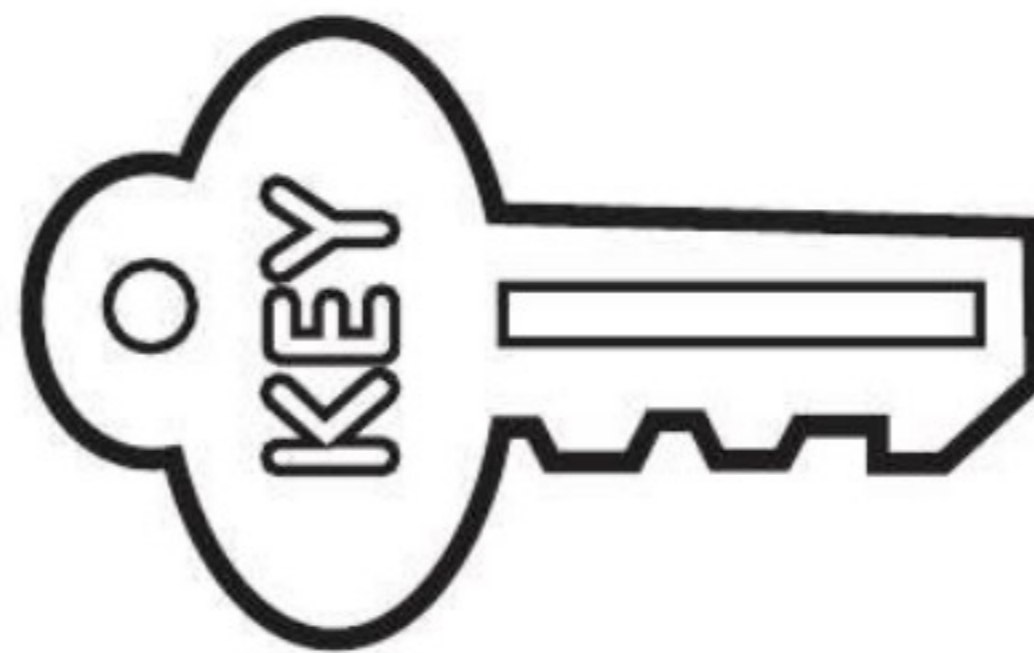







# Letter Kk

These words start with **K** or **k**.

**Directions:** Write  a lowercase **k** on each line.

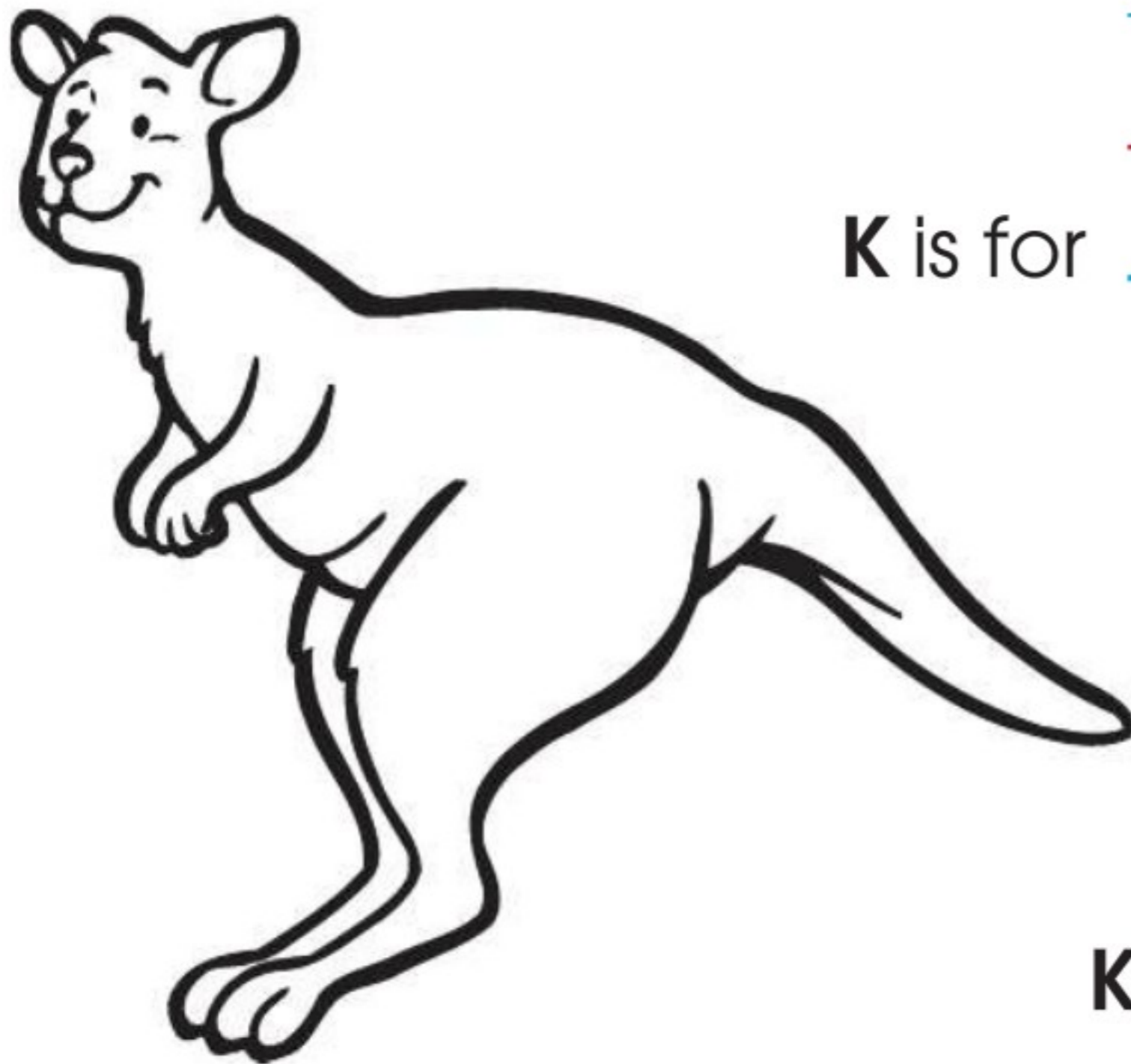
**Color**  the pictures.



**K** is for  kangaroo.

**K** is for \_\_\_\_\_ing.



**K** is for \_\_\_\_\_eg.





# Letter Ll



**Directions:** Trace and write  the letter Ll.

UPPERCASE



lowercase



**Directions:** These pictures begin with the letter Ll.

**Color**  the pictures.

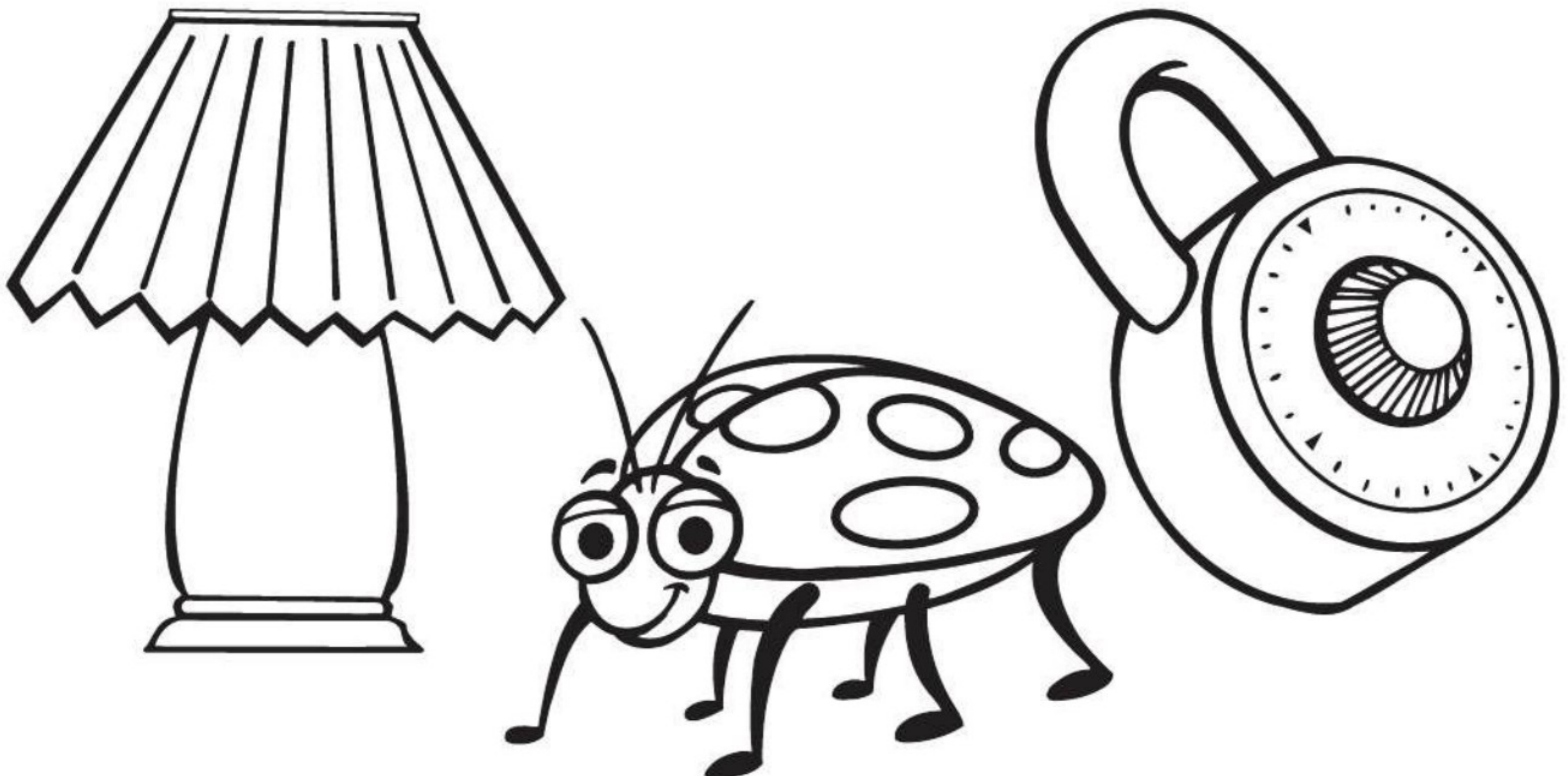



# Letter Ll

It is fun to rake the fall leaves!

**Directions:** Color  the leaves with **L orange**. Color  the leaves with **l red**.





# Letter Ll

**Directions:** Circle  the L or I in these words:

letter

Larry

lion

Leah

lamp

ladder

**Directions:** Color  the pictures that start with the sound of Ll.

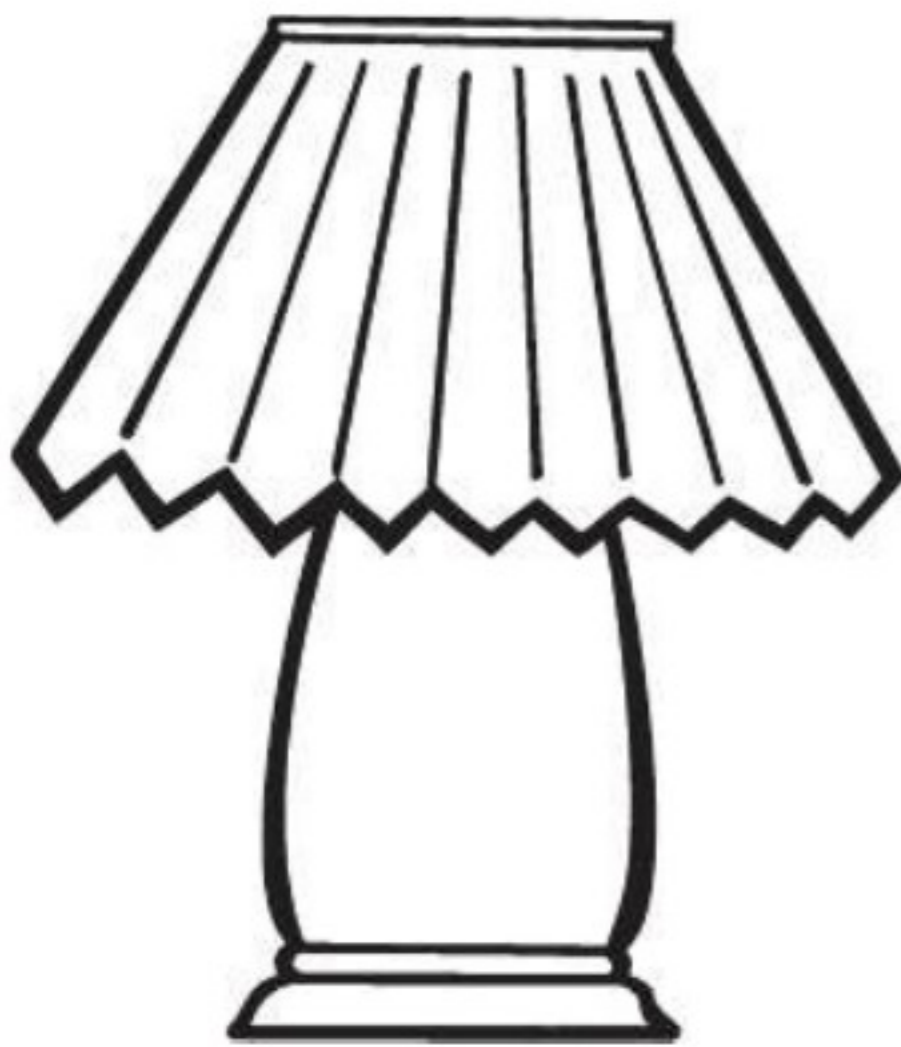



## Letter Ll

Lucy lost her luggage! Help her find it.

**Directions:** Color  the pictures on the luggage that begin with the sound of **Ll**. Then, **color**  Lucy's clothes!

luggage

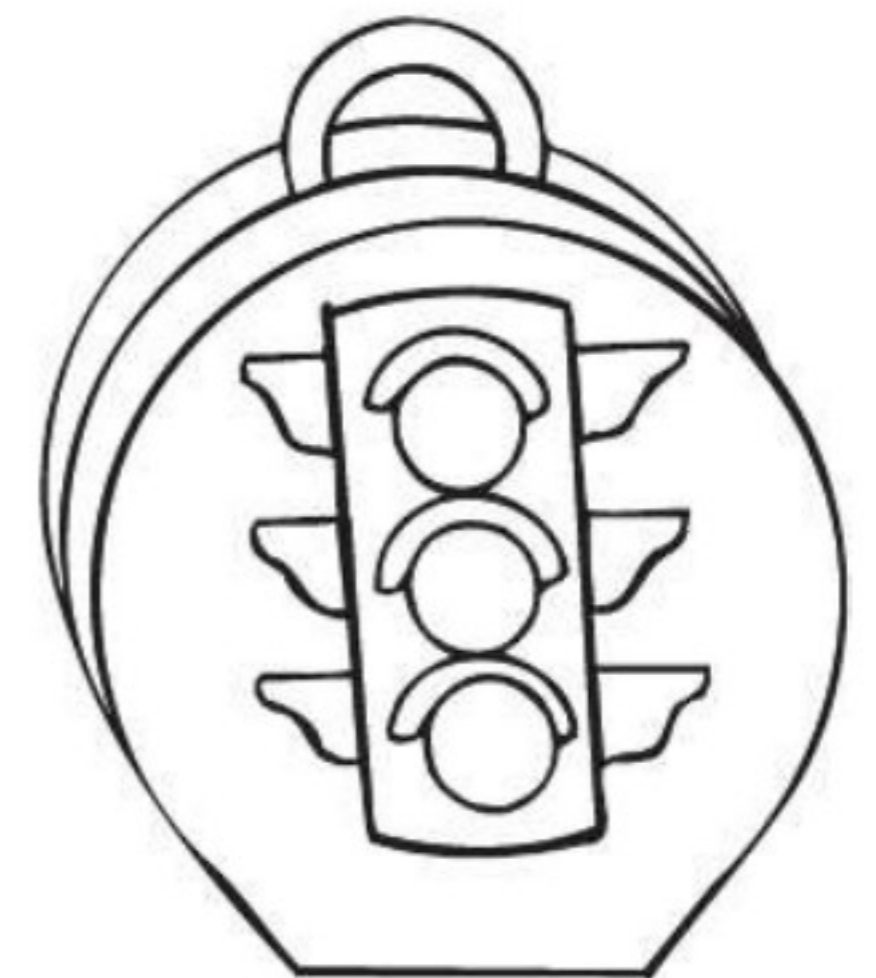
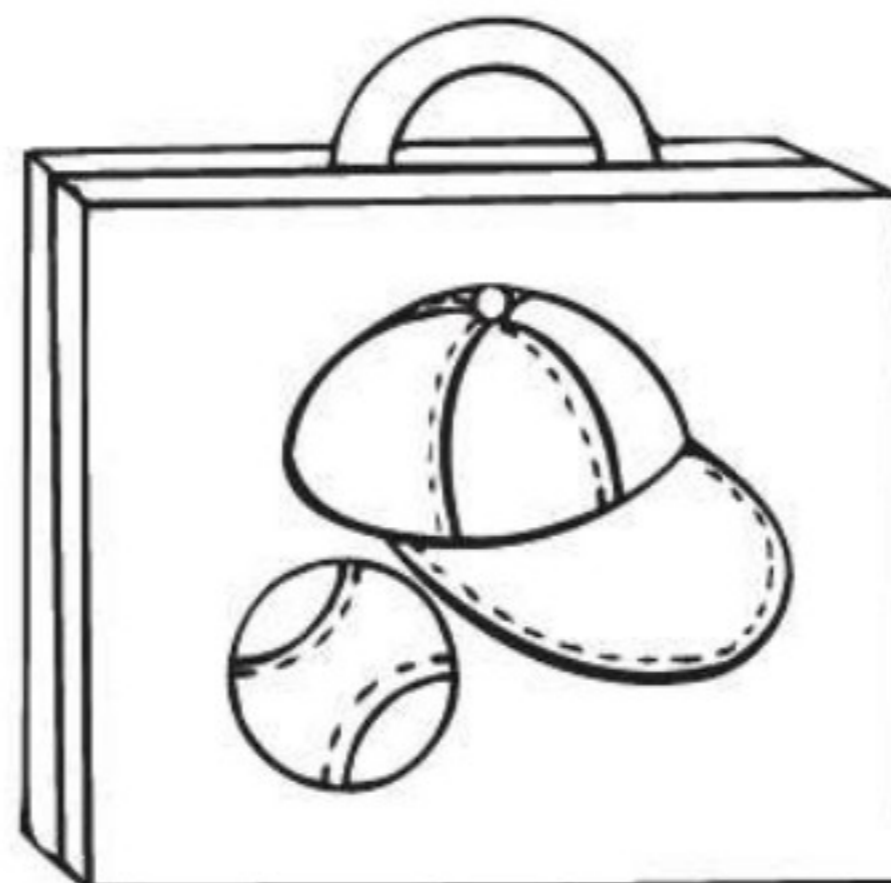



# Letter Mm



**Directions:** Trace and write  the letter Mm.

UPPERCASE



lowercase



**Directions:** These pictures begin with the letter Mm.

**Color**  the pictures.





# Letter Mm

You can help the  find the cheese.

**Directions:** Draw  a **green** line to follow each **M** and **m**.

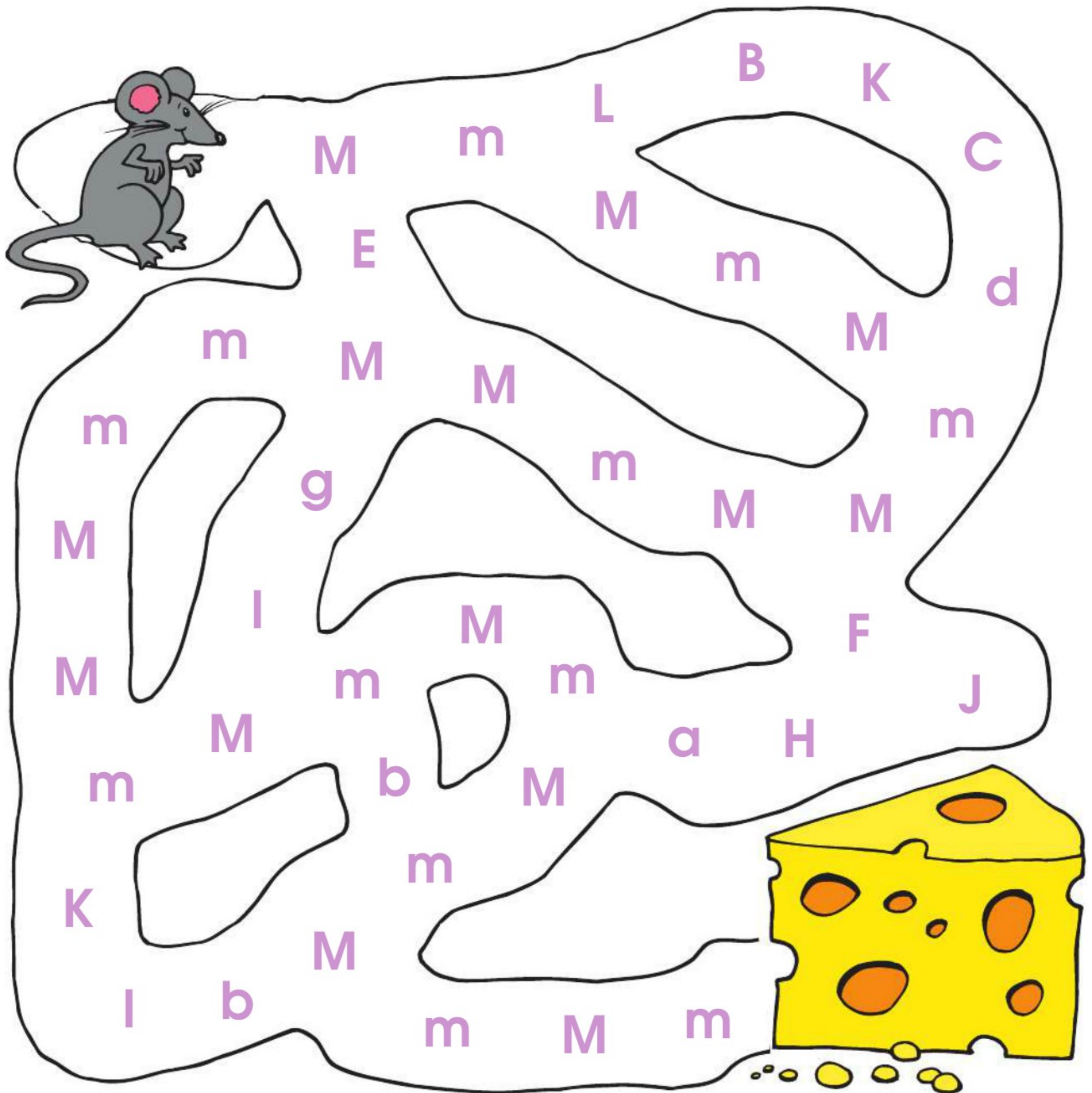



# Letter Mm

**Directions:** Circle  the **M** or **m** in these words:

man

monkey

Maria

mask

make

Martin

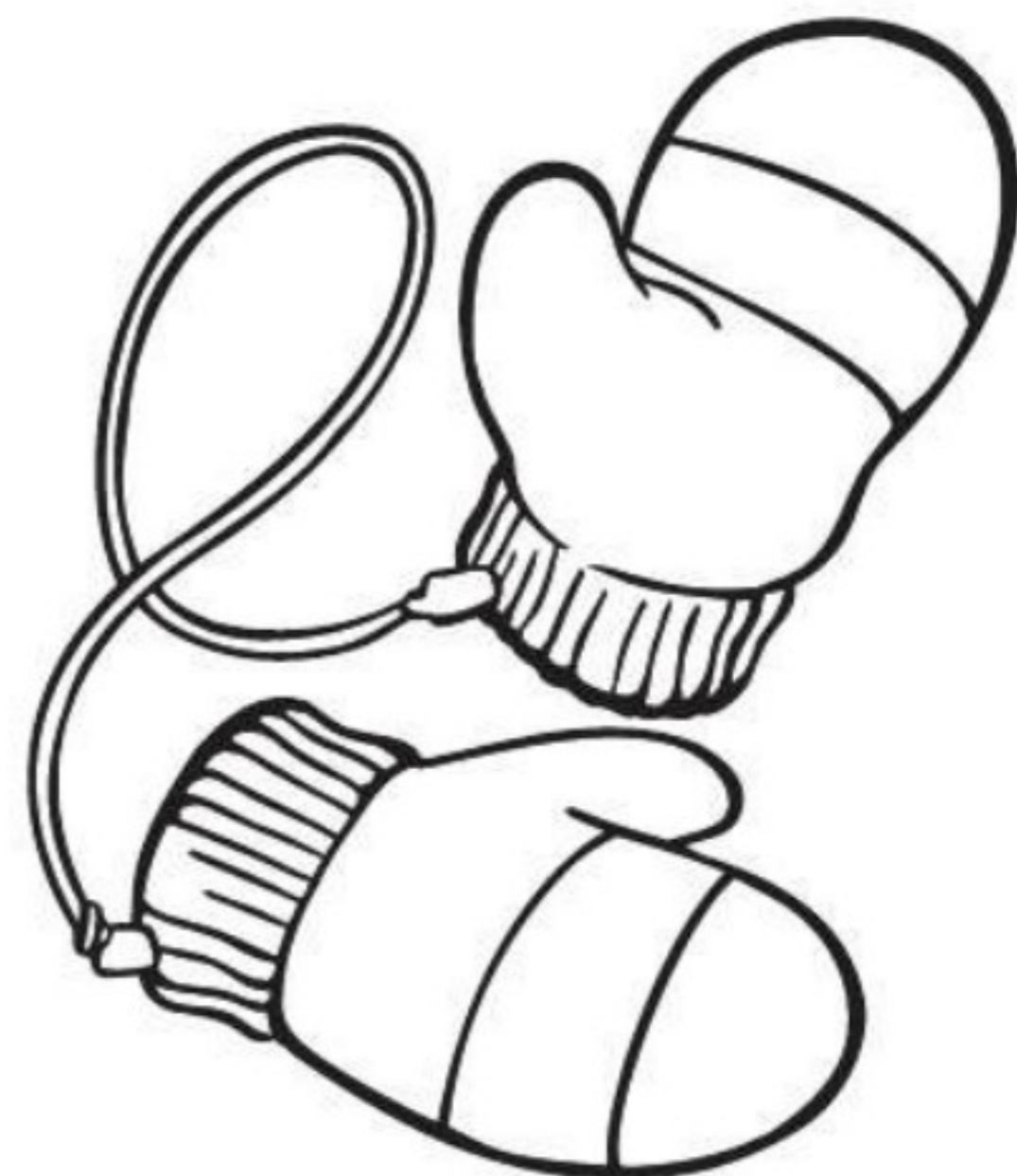
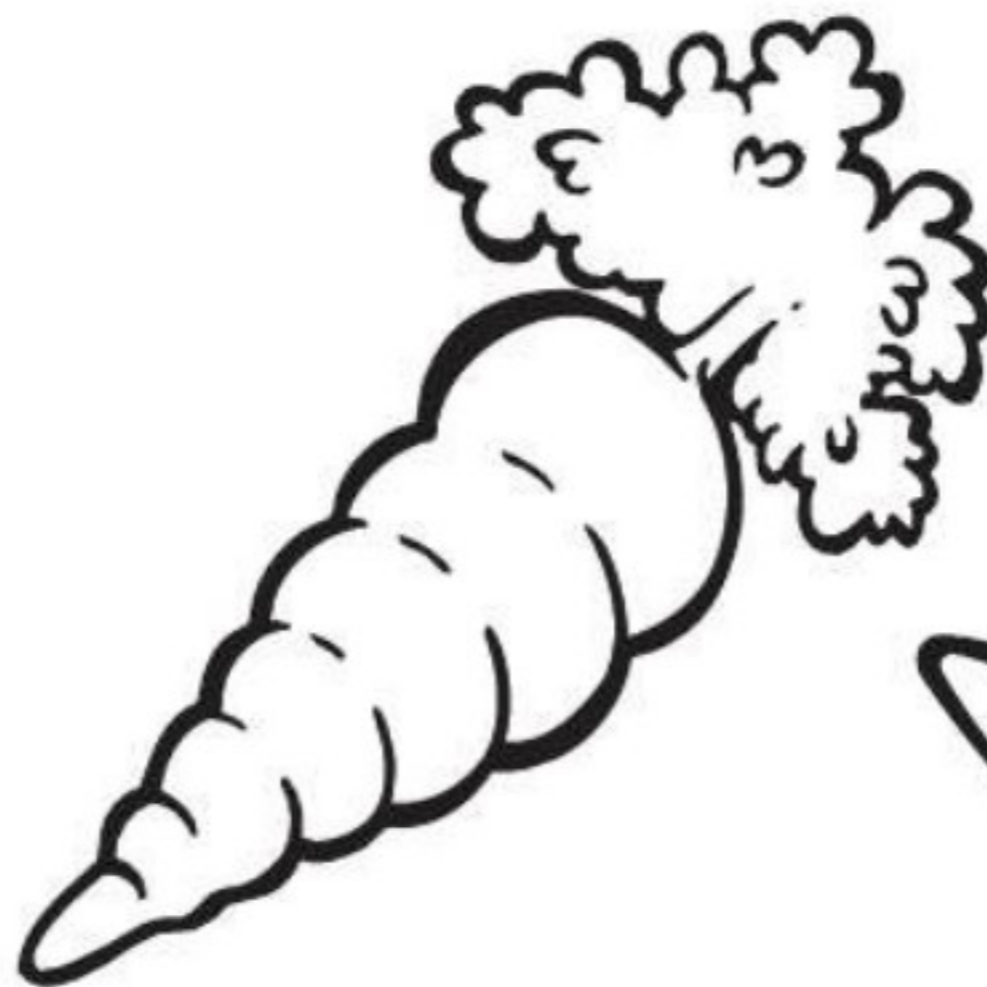

**Directions:** Color  the pictures that start with the sound of **Mm**.







# Letter Mm

**Directions:** Draw  a line from each  to a picture that begins with the sound of **Mm**. Color  the pictures.

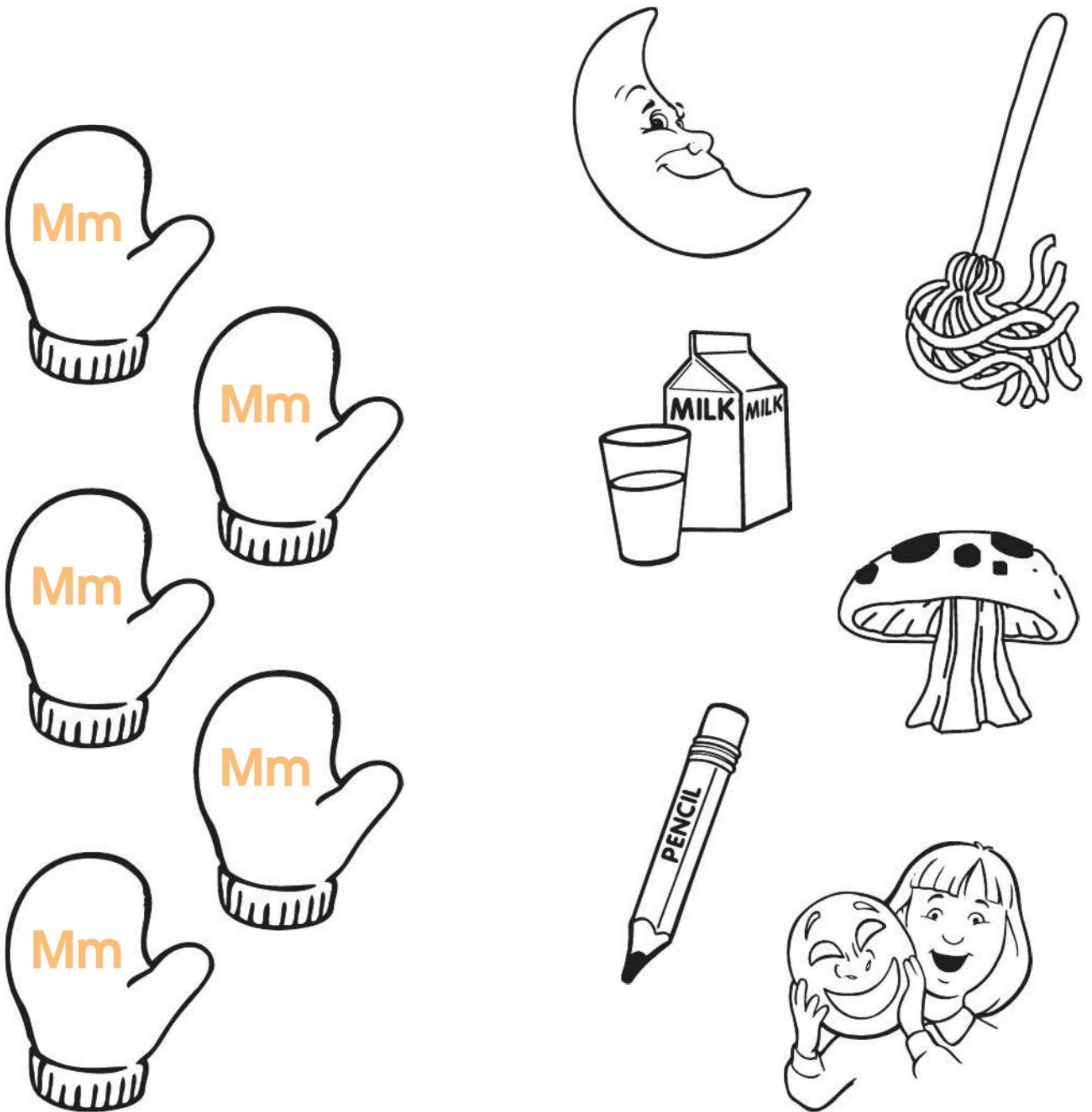



# Letter Nn



**Directions:** Trace and write  the letter Nn.

UPPERCASE



lowercase



**Directions:** These pictures begin with the letter Nn.

**Color**  the pictures.

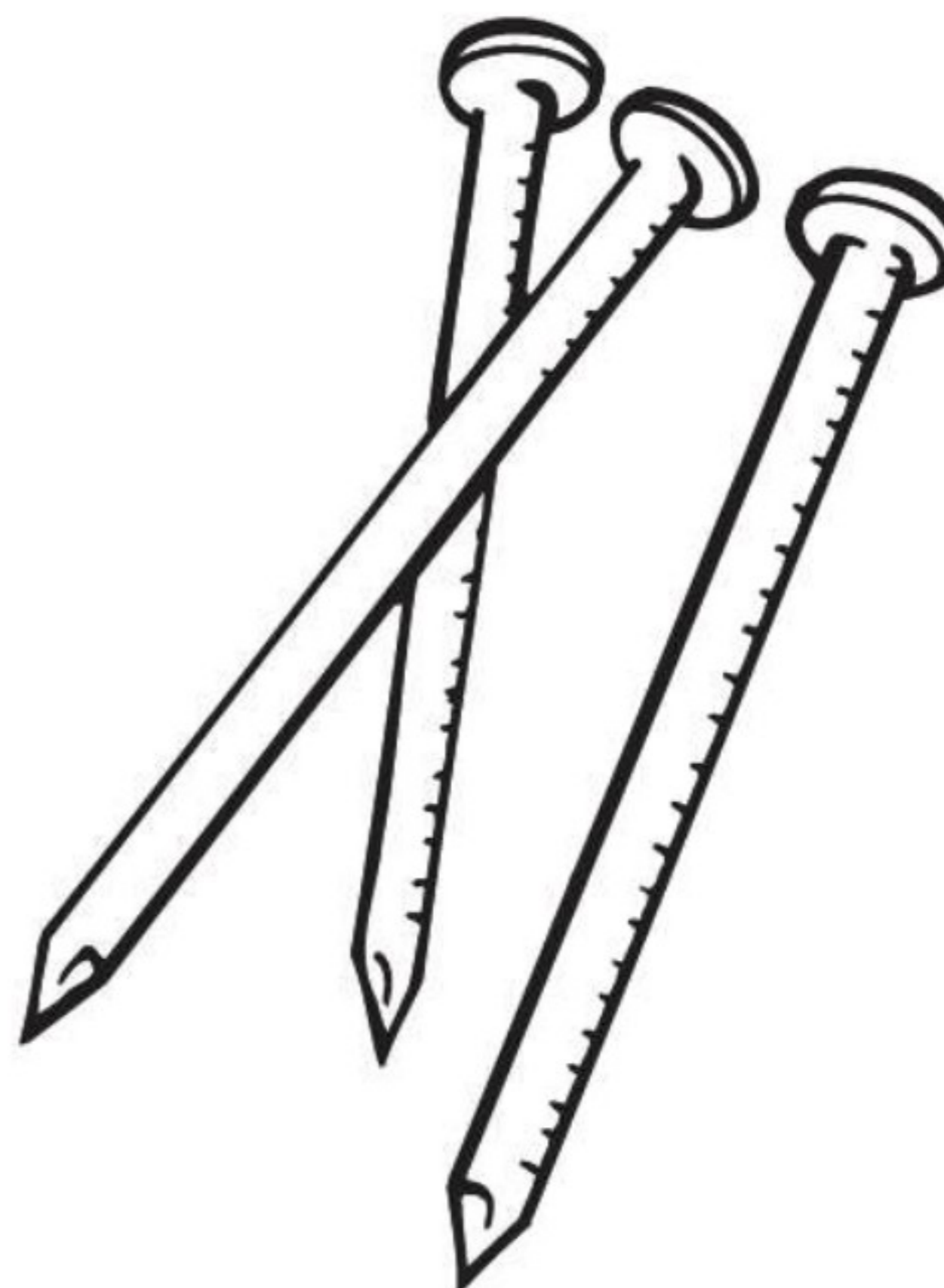
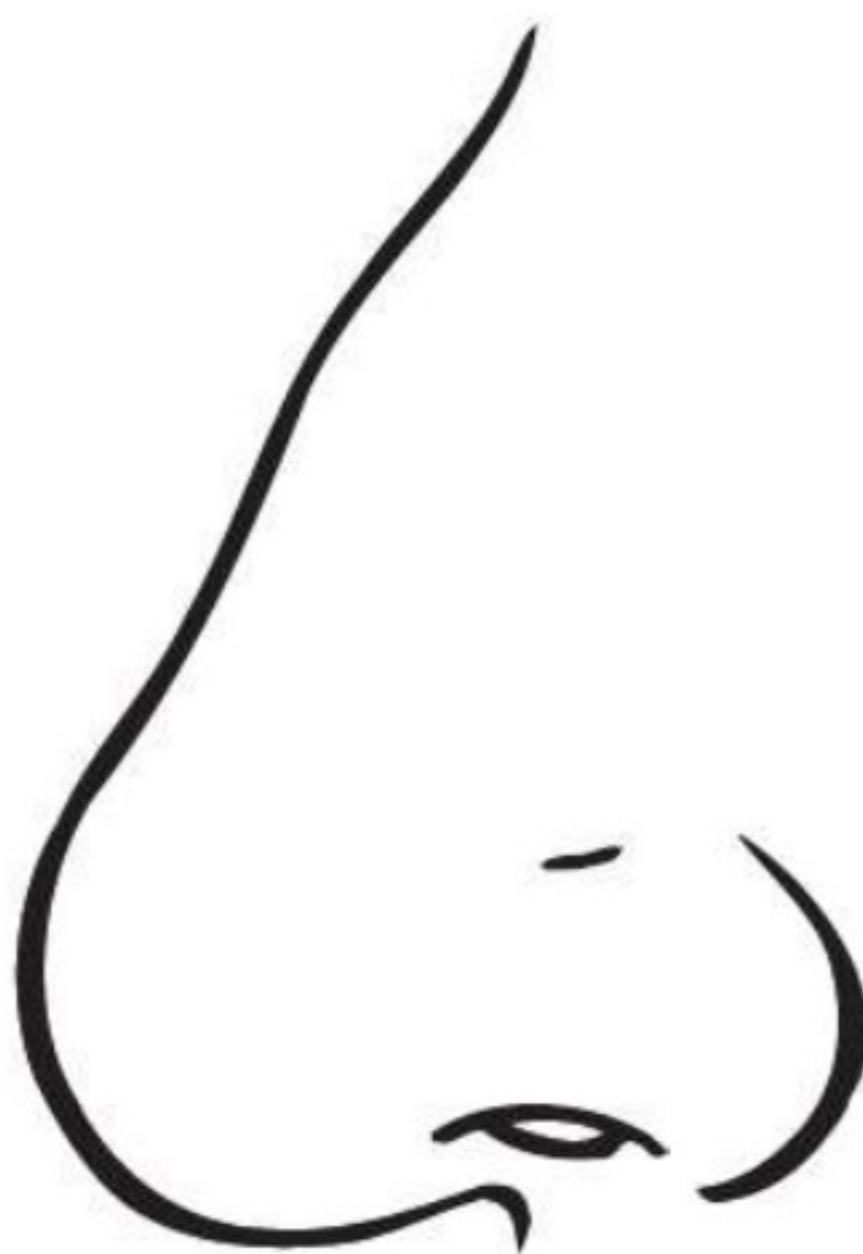
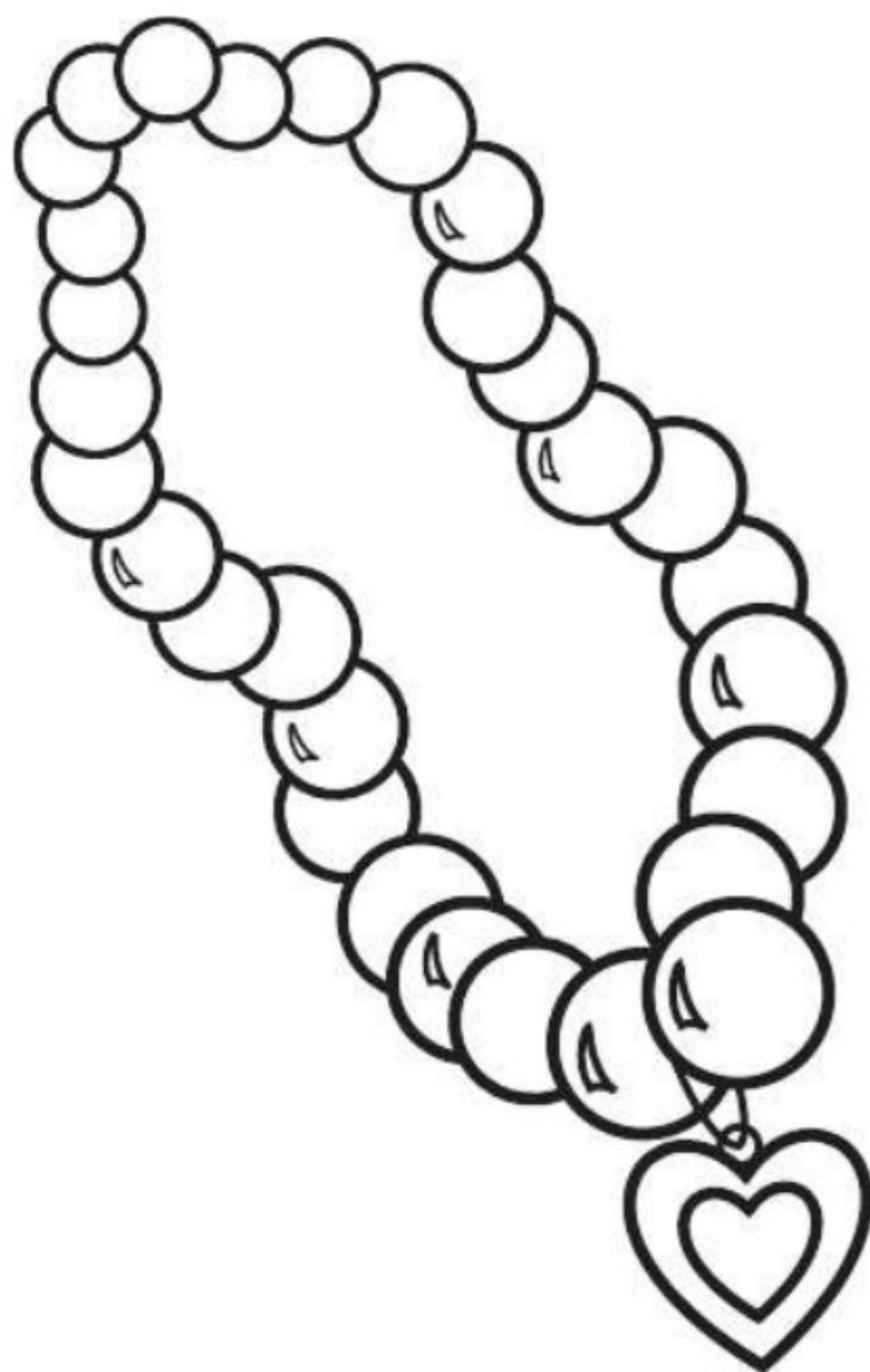



## Letter Nn

Can you find each **N** and **n** that is hidden in the room?

**Directions:** Color  each **N** purple and each **n** orange. Then, color  the rest of the room!

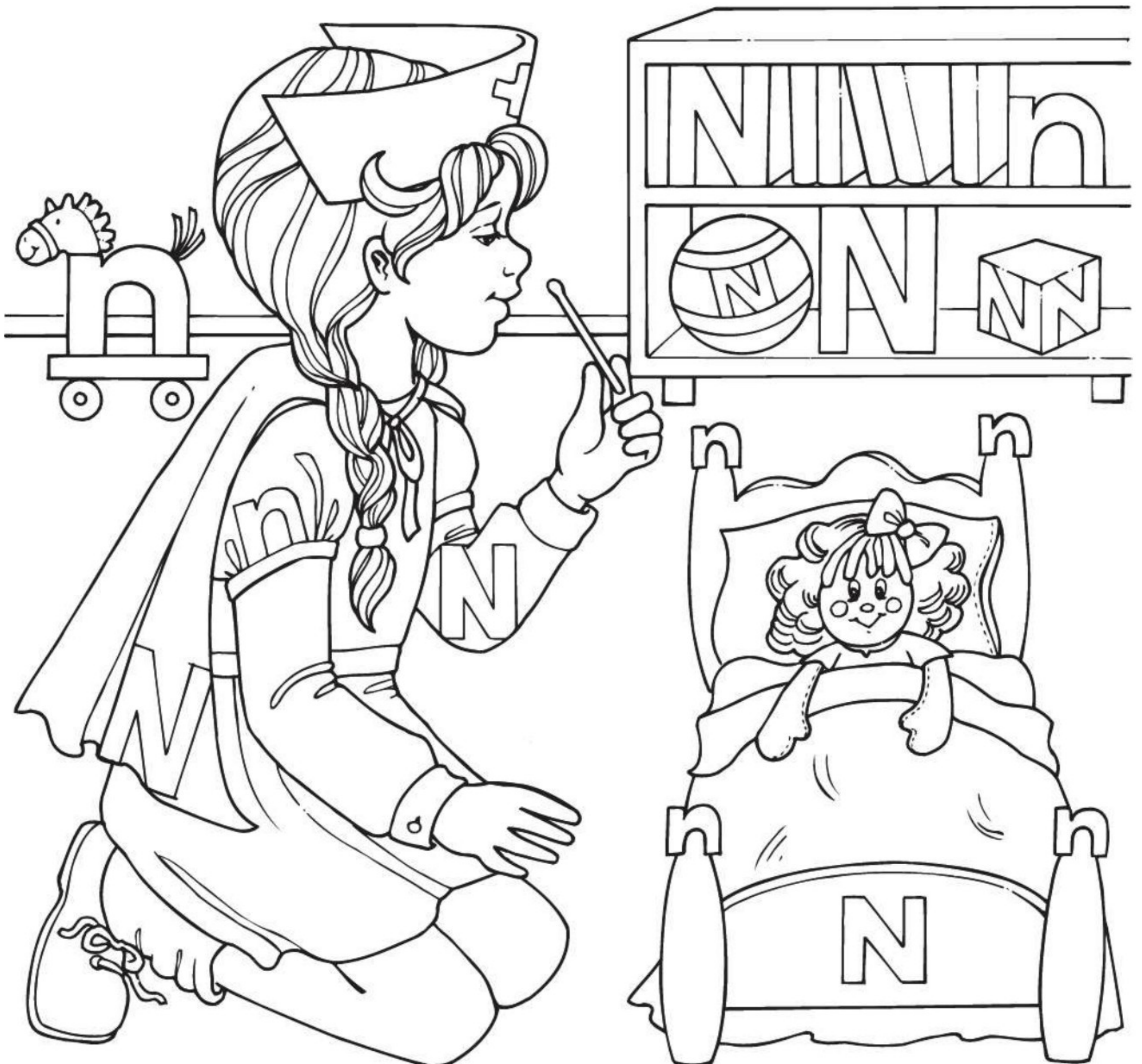



# Letter Nn

**Directions:** Circle  the **N** or **n** in these words:

**Nathan**

**net**

**nine**

**no**

**nest**

**Nancy**

**Directions:** Color  the pictures that start with the sound of **Nn**.

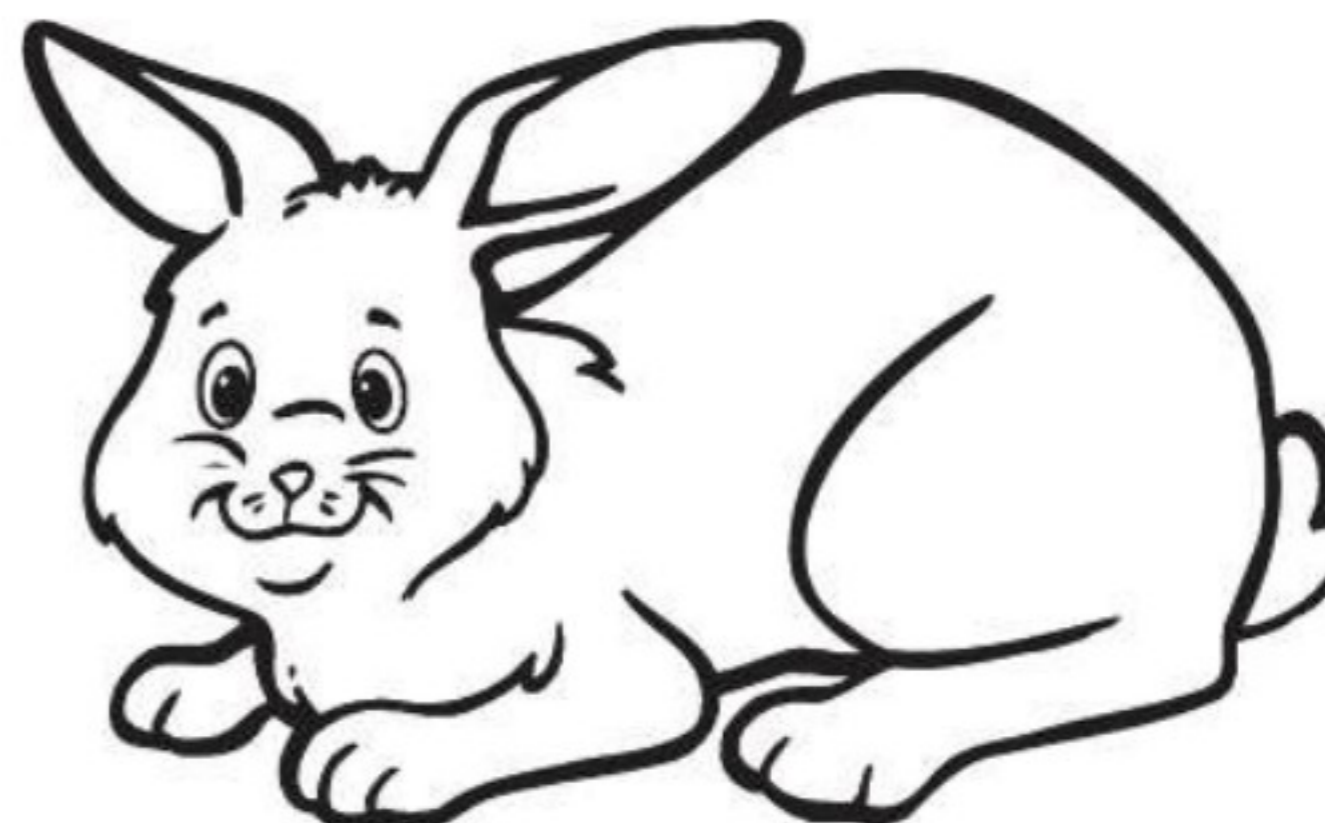
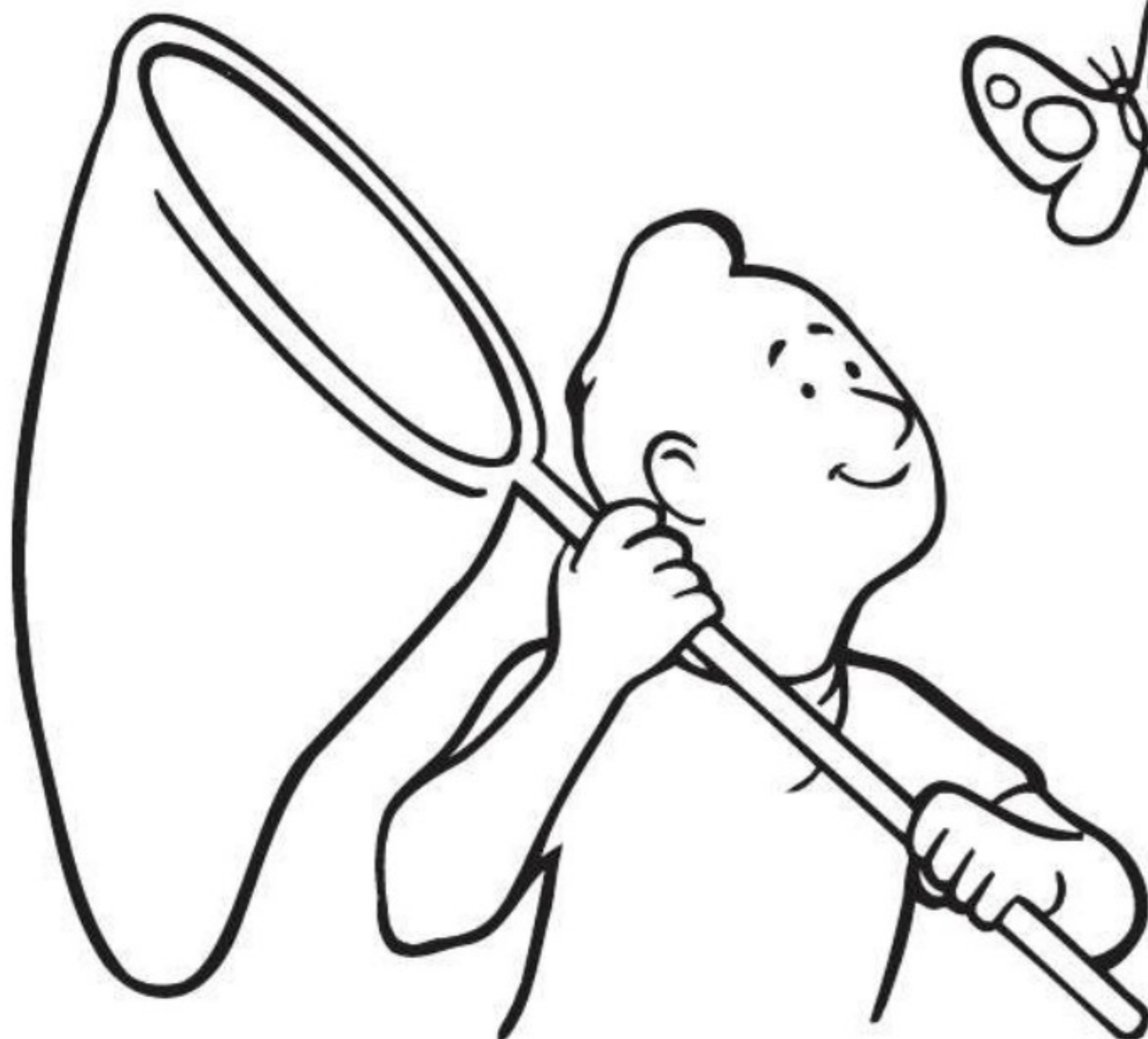



# Letter Nn

These words start with **N** or **n**.

**Directions:** Write  a lowercase **n** on each line.

**Color**  the pictures.



**N** is for  est.



**N** is for  uts.



**N** is for  et.



# Letter Oo



**Directions:** Trace and write  the letter Oo.

UPPERCASE



lowercase

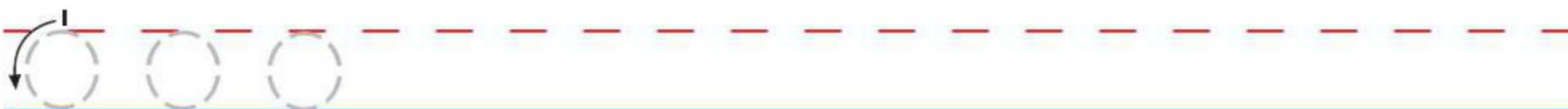

**Directions:** These pictures begin with the letter Oo.

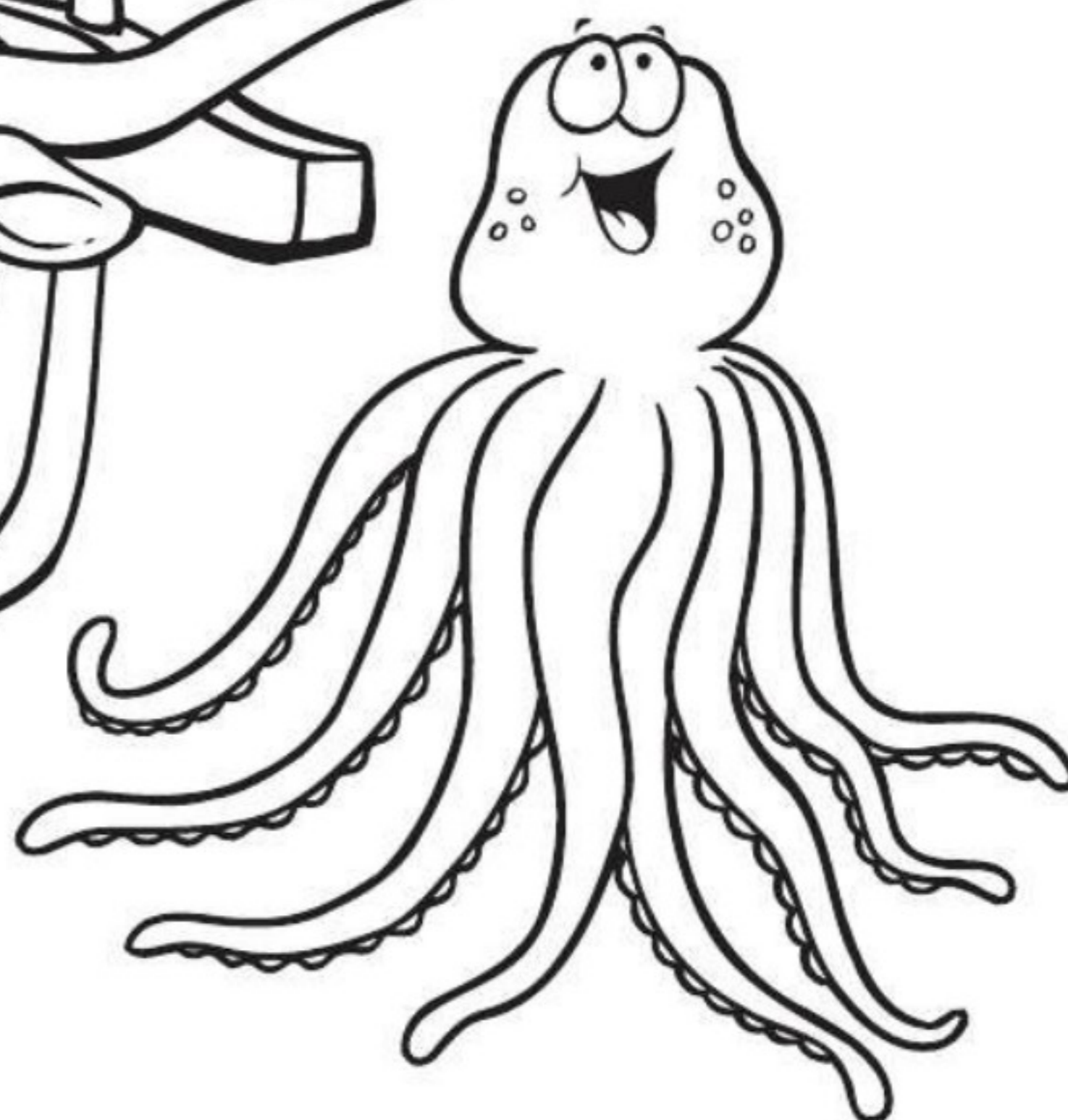

**Color**  the pictures.





# Letter Oo

See what has 8 legs and lives in the ocean.

**Directions:** Color  the spaces with **Oo** brown. Color  the other spaces **blue**.

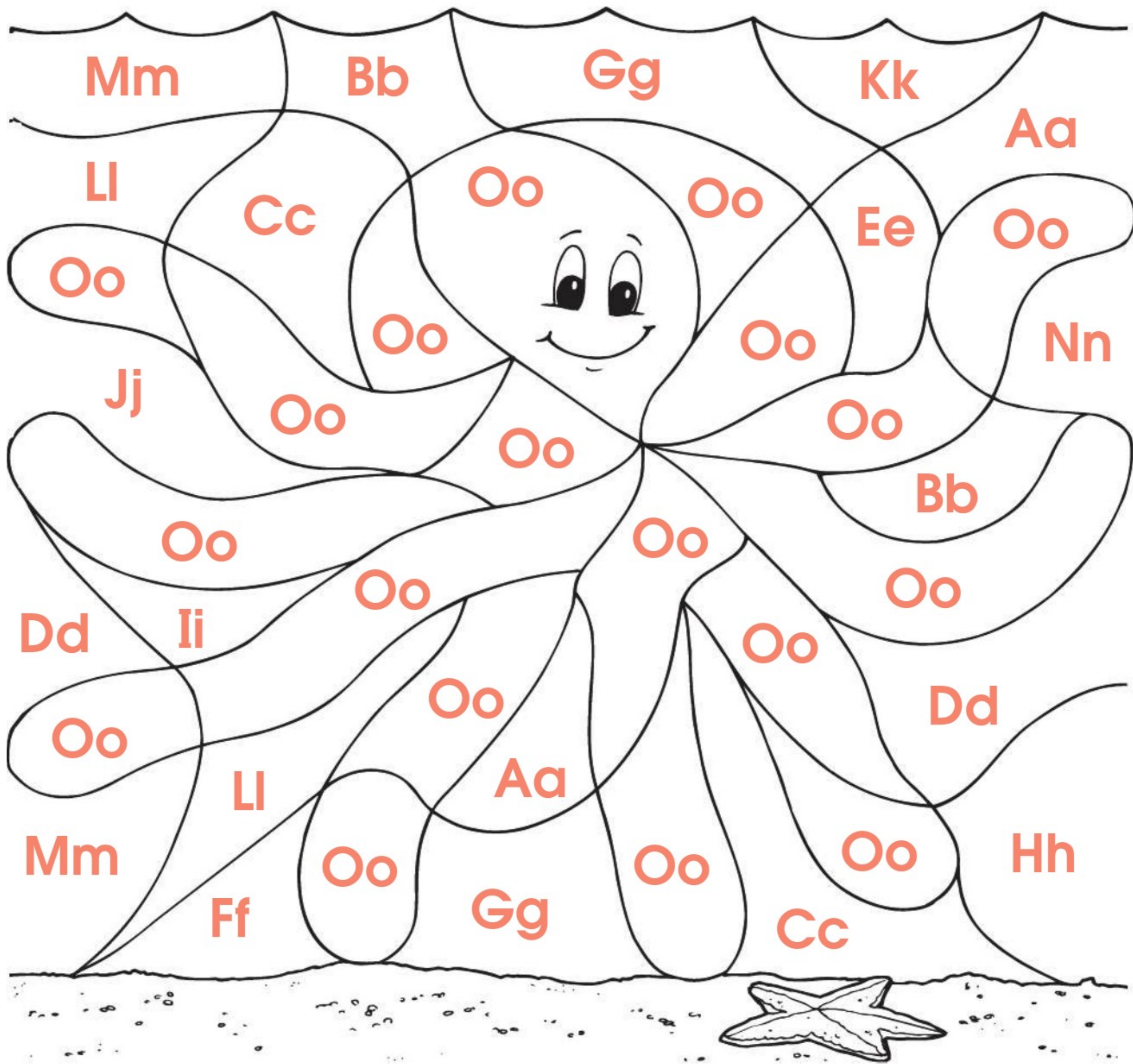



# Letter Oo

**Directions:** Circle  the **O** or **o** in these words:

Olivia

owl

octopus

once

only

Owen

**Directions:** Color  the pictures that start with the sound of **Oo**.

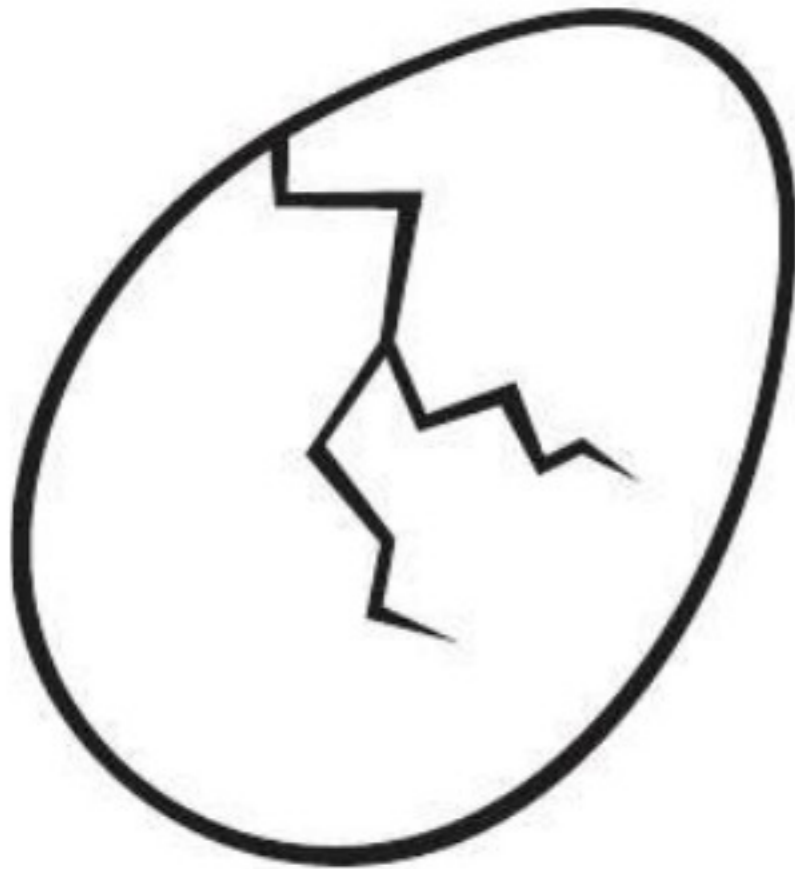





# Letter Oo

These words start with O or o.

**Directions:** Write  a lowercase o on each line.

**Color**  the pictures.



O is for  strich.

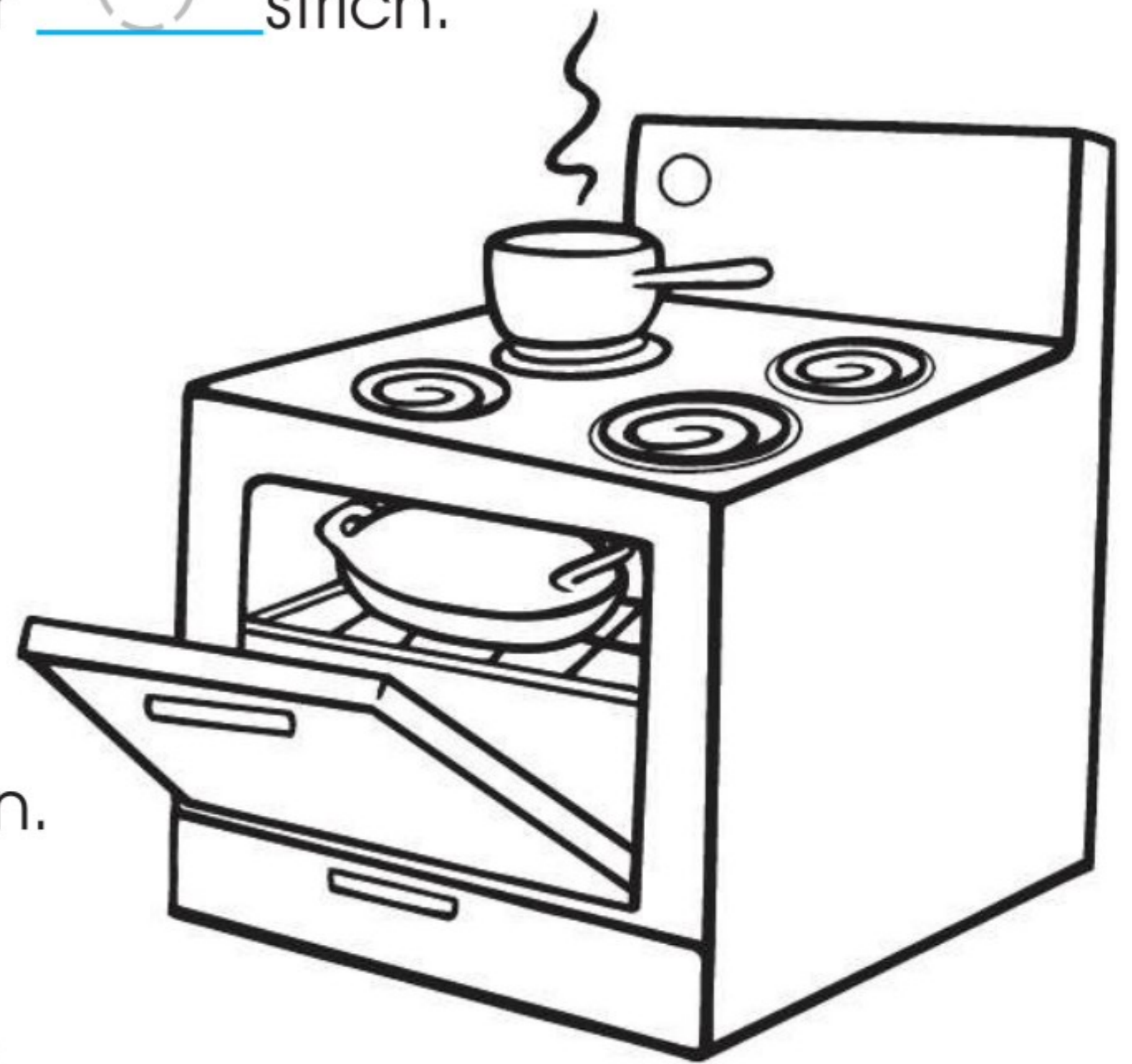

O is for  ven.

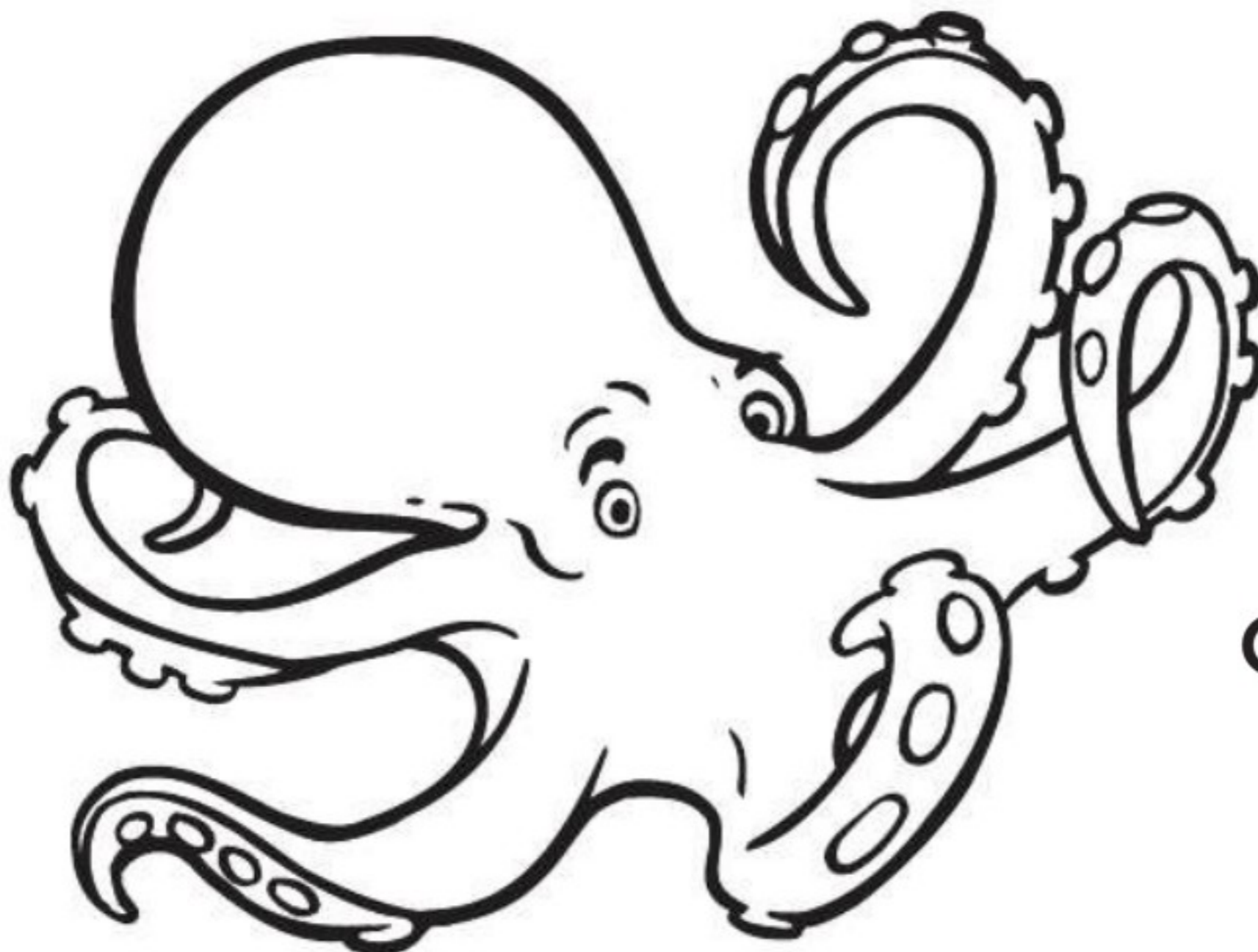

O is for  ctopus.



# Letter Pp



**Directions:** Trace and write  the letter Pp.

UPPERCASE



lowercase



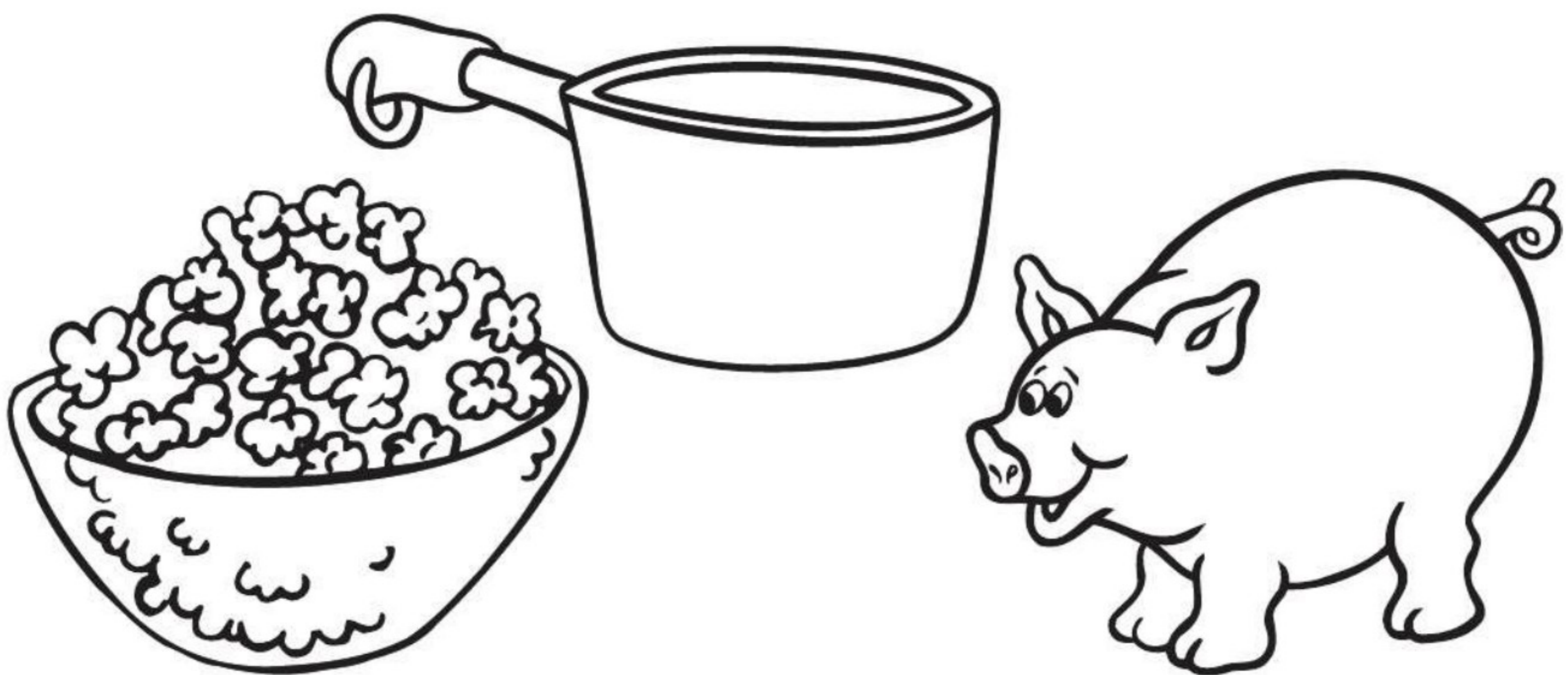

**Directions:** These pictures begin with the letter Pp.

**Color**  the pictures.





# Letter Pp

**Directions:** Color  each **P** or **p** on the pizza **red**. Then, color  the rest of the pizza.

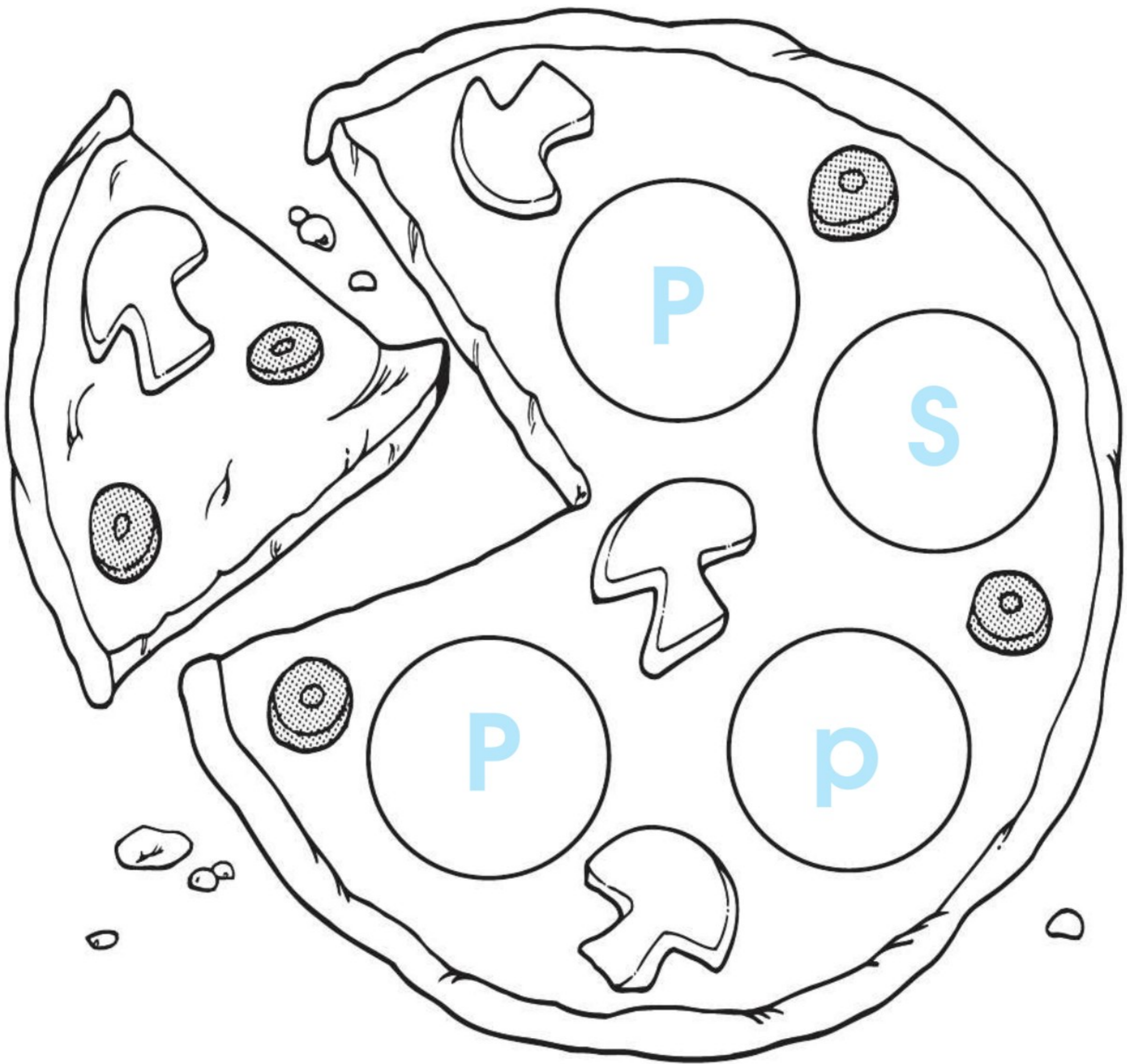



# Letter Pp

**Directions:** Circle  the **P** or **p** in these words:

pencil

Paul

pig

party

penny

Patty

**Directions:** Color  the pictures that start with the sound of **Pp**.

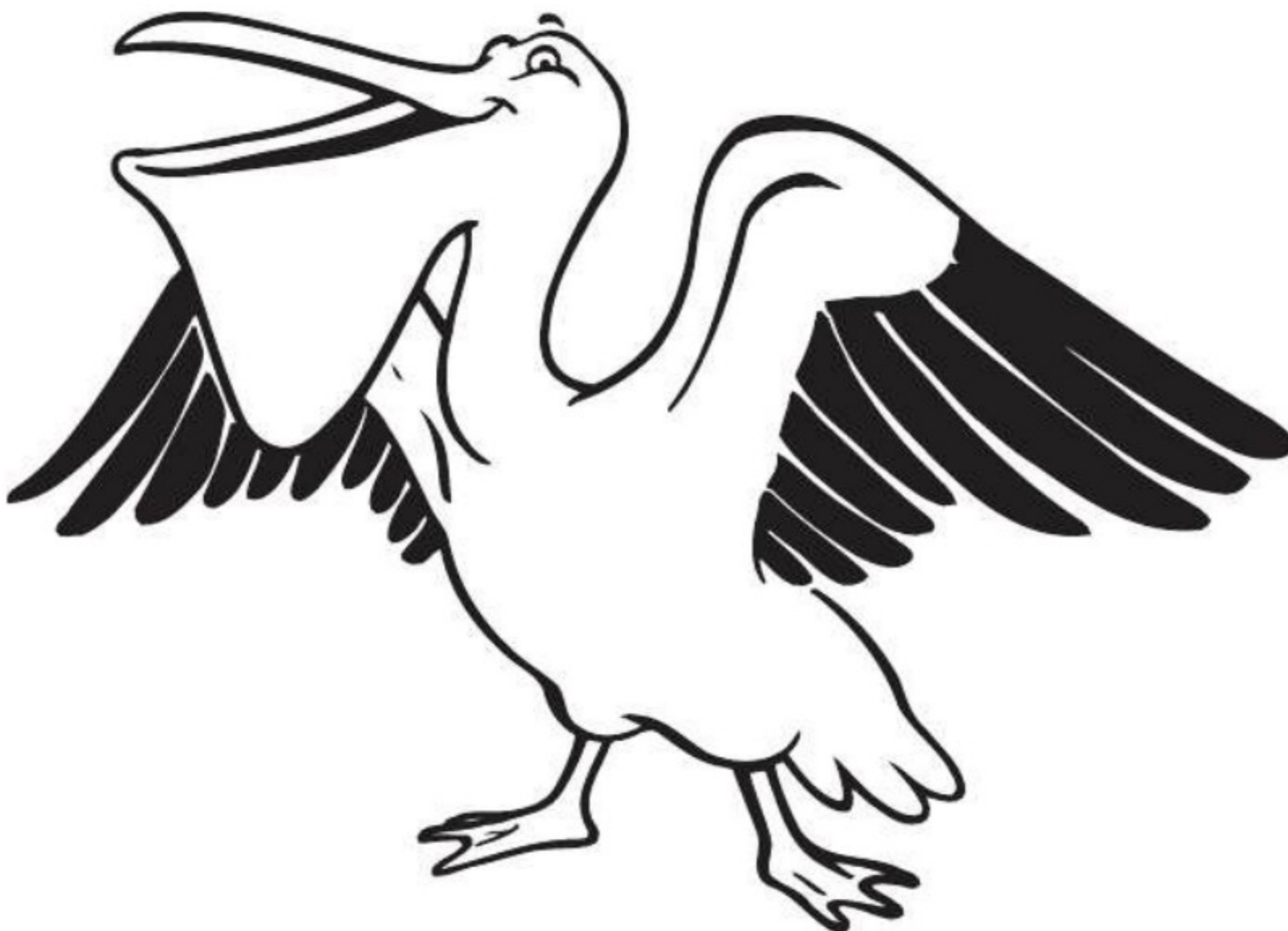



# Letter Pp

**Directions:** If the picture begins with the sound of **Pp**, leave the space white. **Color**  all of the other spaces **red** to find a popping good snack!





# Letter Qq



**Directions:** Trace and write  the letter Qq.

UPPERCASE



lowercase

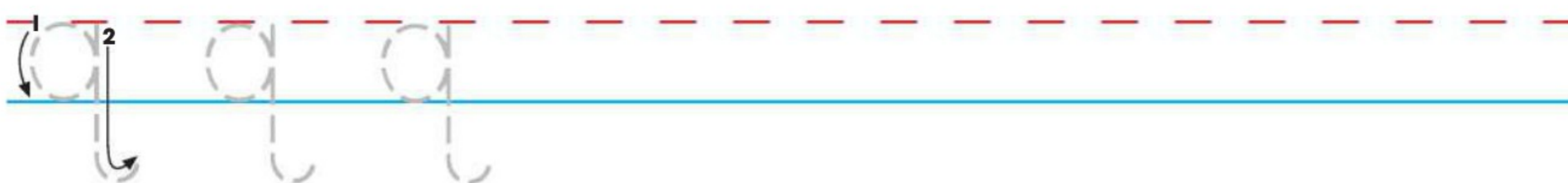

**Directions:** These pictures begin with the letter Qq.

**Color**  the pictures.

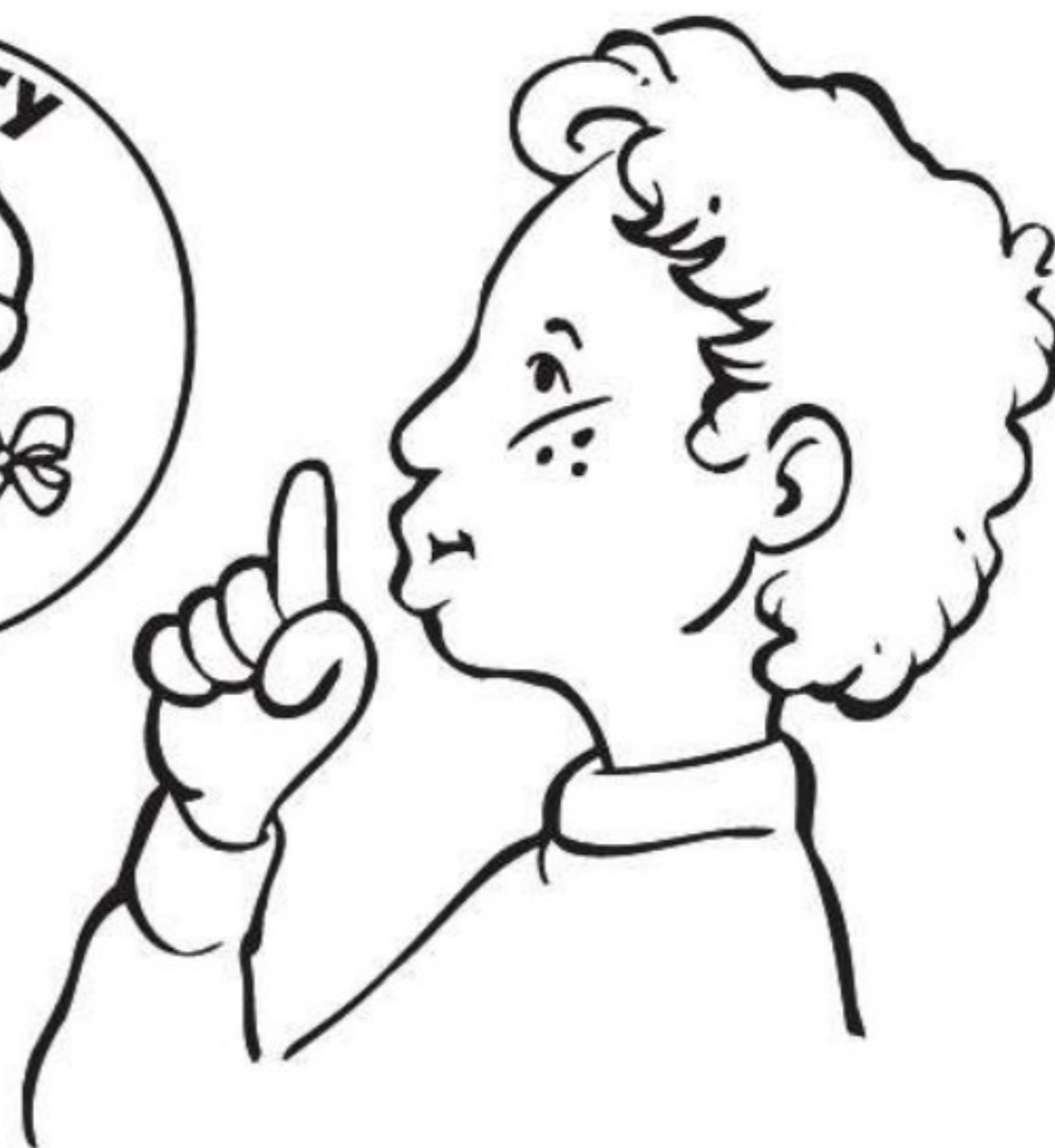
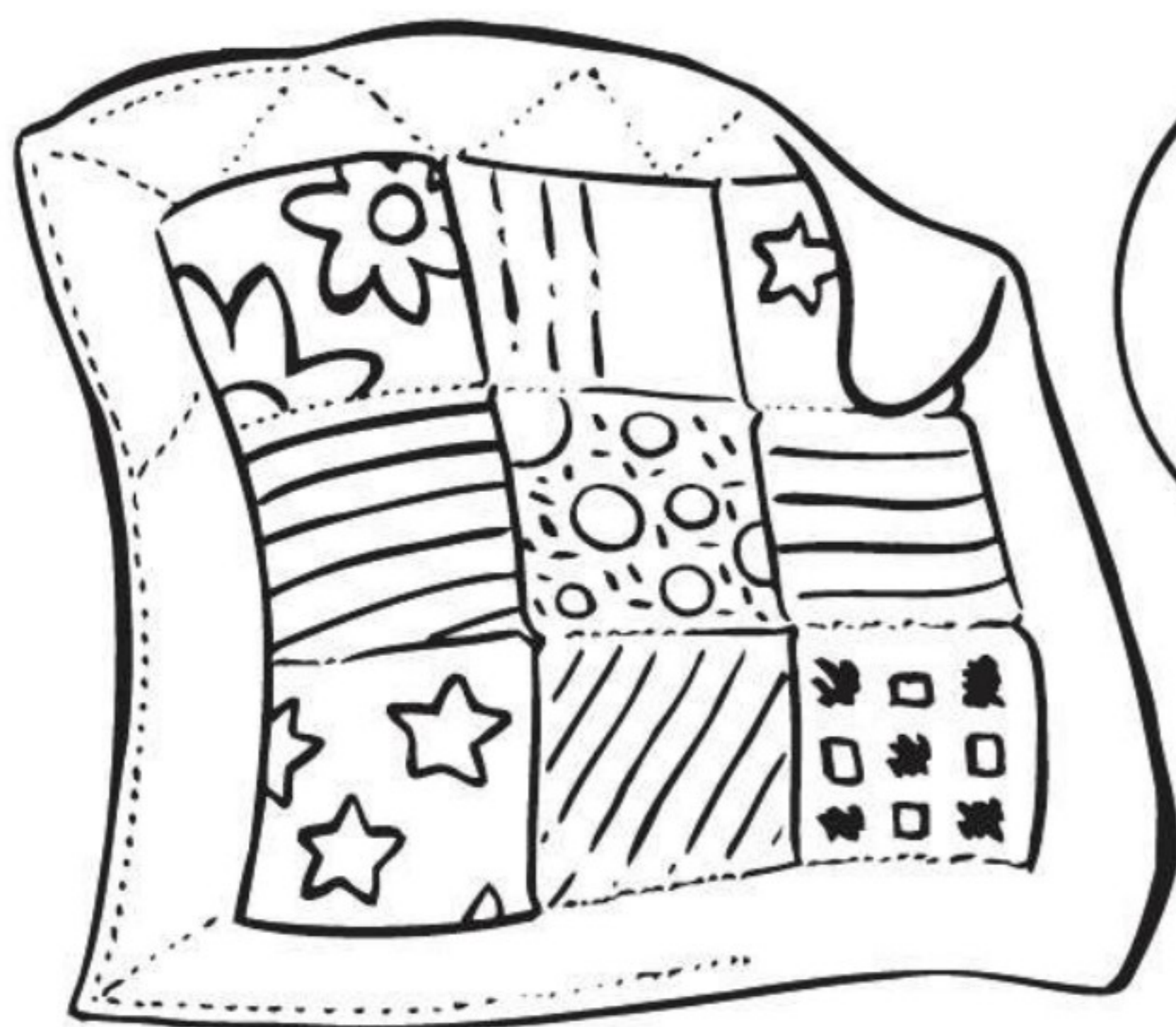



## Letter Qq

Look how quiet everything in the picture seems.

**Directions:** Can you find each **Q** and **q**? Color  each **Q** blue and each **q** yellow.

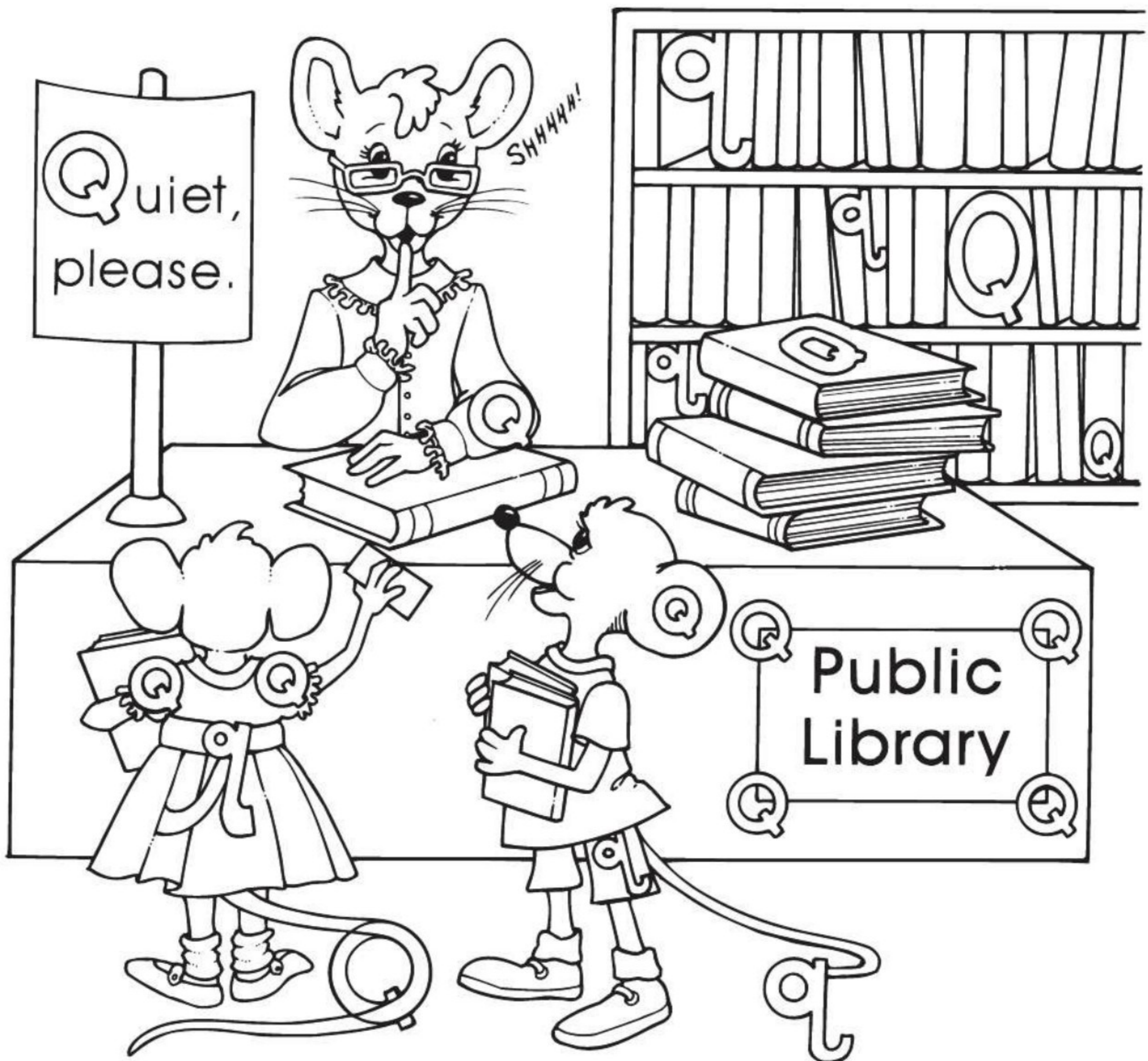



# Letter Qq

**Directions:** Circle  the **Q** or **q** in these words:

Quincy

quarter

quilt

quit

Quake

quiet

**Directions:** Color  the pictures that start with the sound of **Qq**.

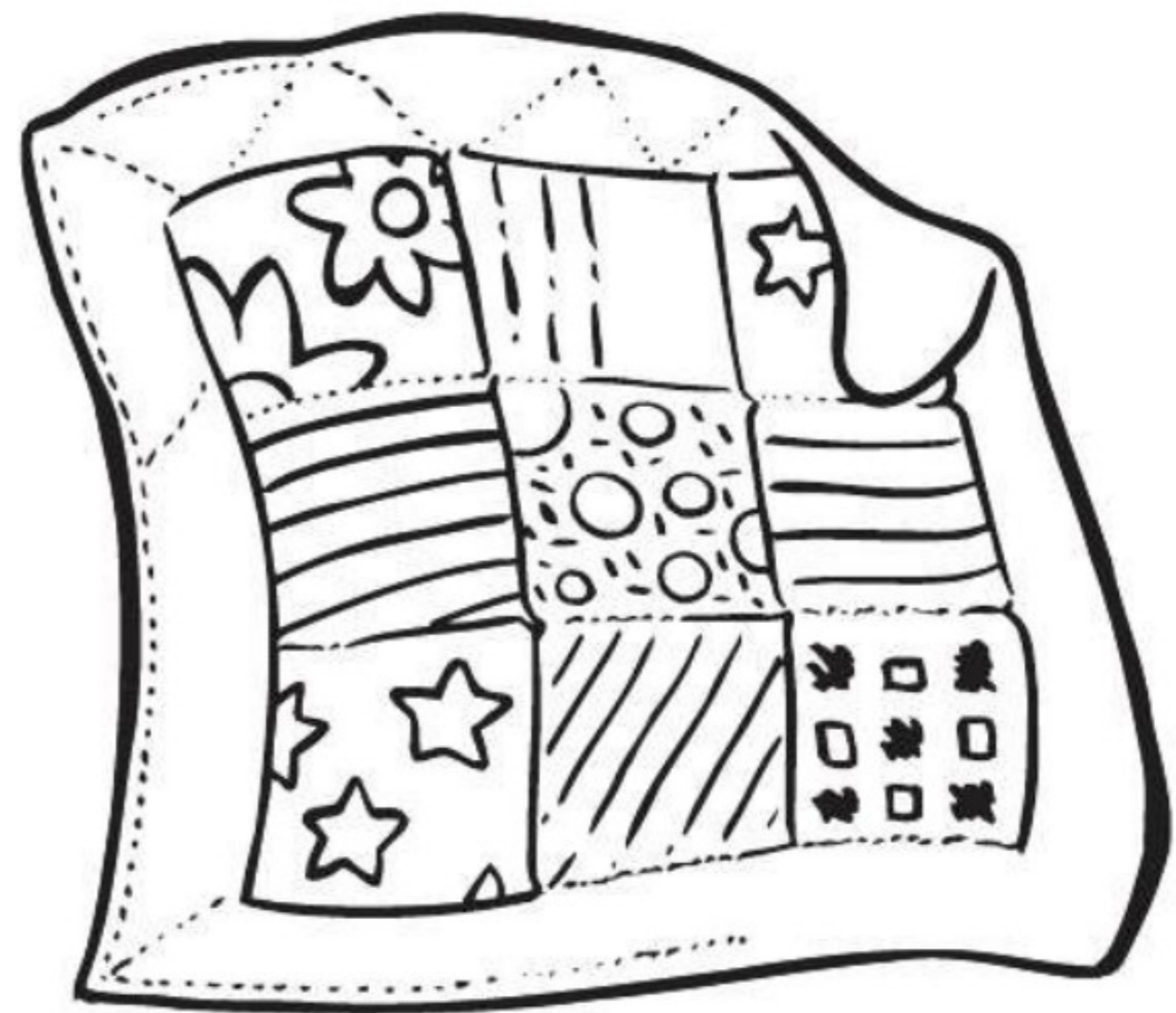





# Letter Qq

**Directions:** Color  the squares with pictures that begin with the sound of **Qq** **red**. Color  all of the other squares **yellow**.

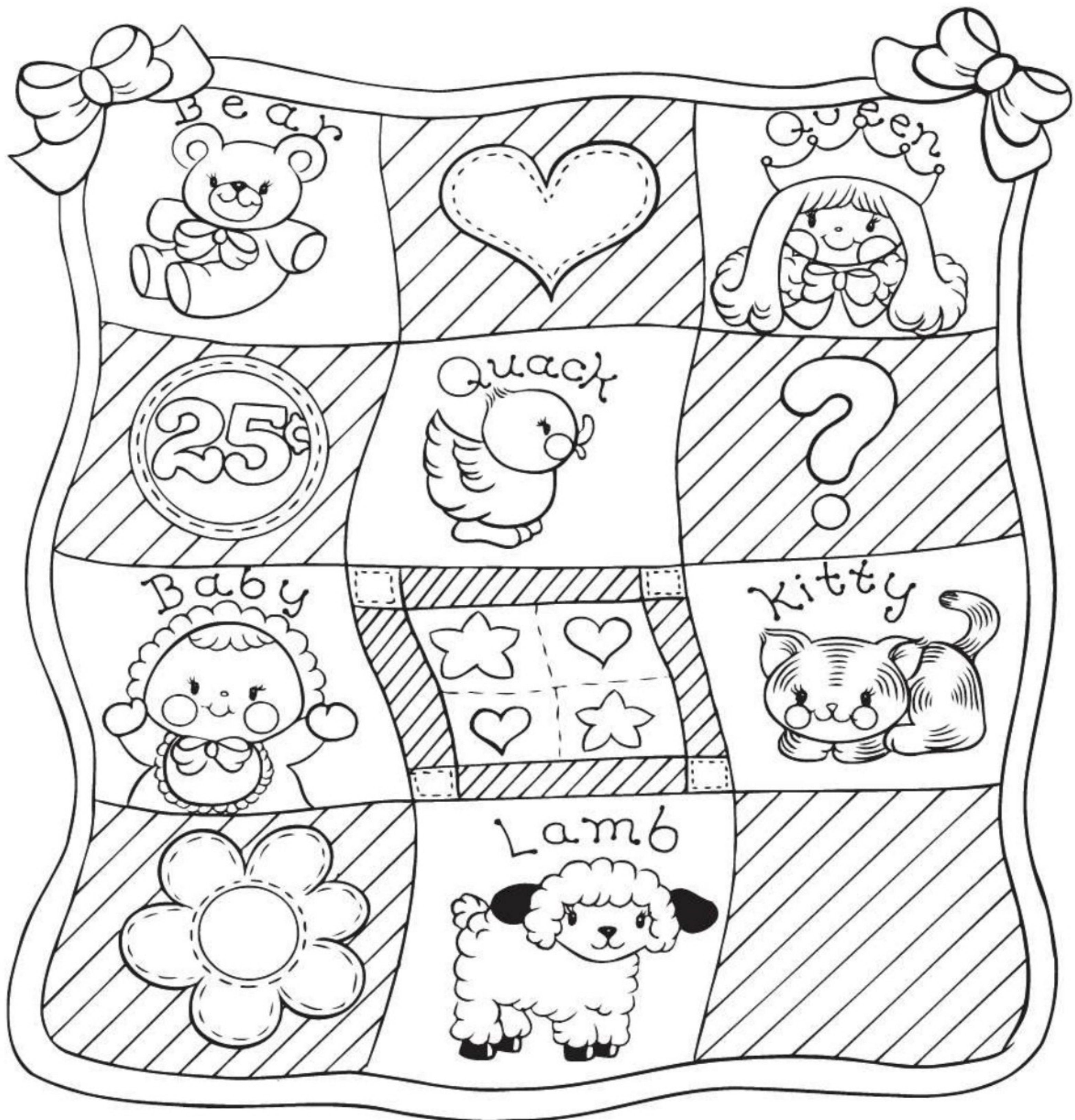



# Letter Rr



**Directions:** Trace and write  the letter Rr.

UPPERCASE

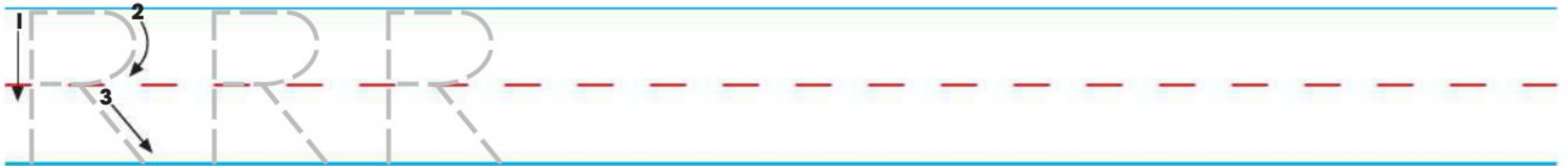

lowercase





**Directions:** These pictures begin with the letter Rr.

**Color**  the pictures.





# Letter Rr

**Directions:** Trace  each **R** and **r**. Color  each raindrop with **R green**. Color  each raindrop with **r blue**. Use the same colors for the letters on the umbrella.

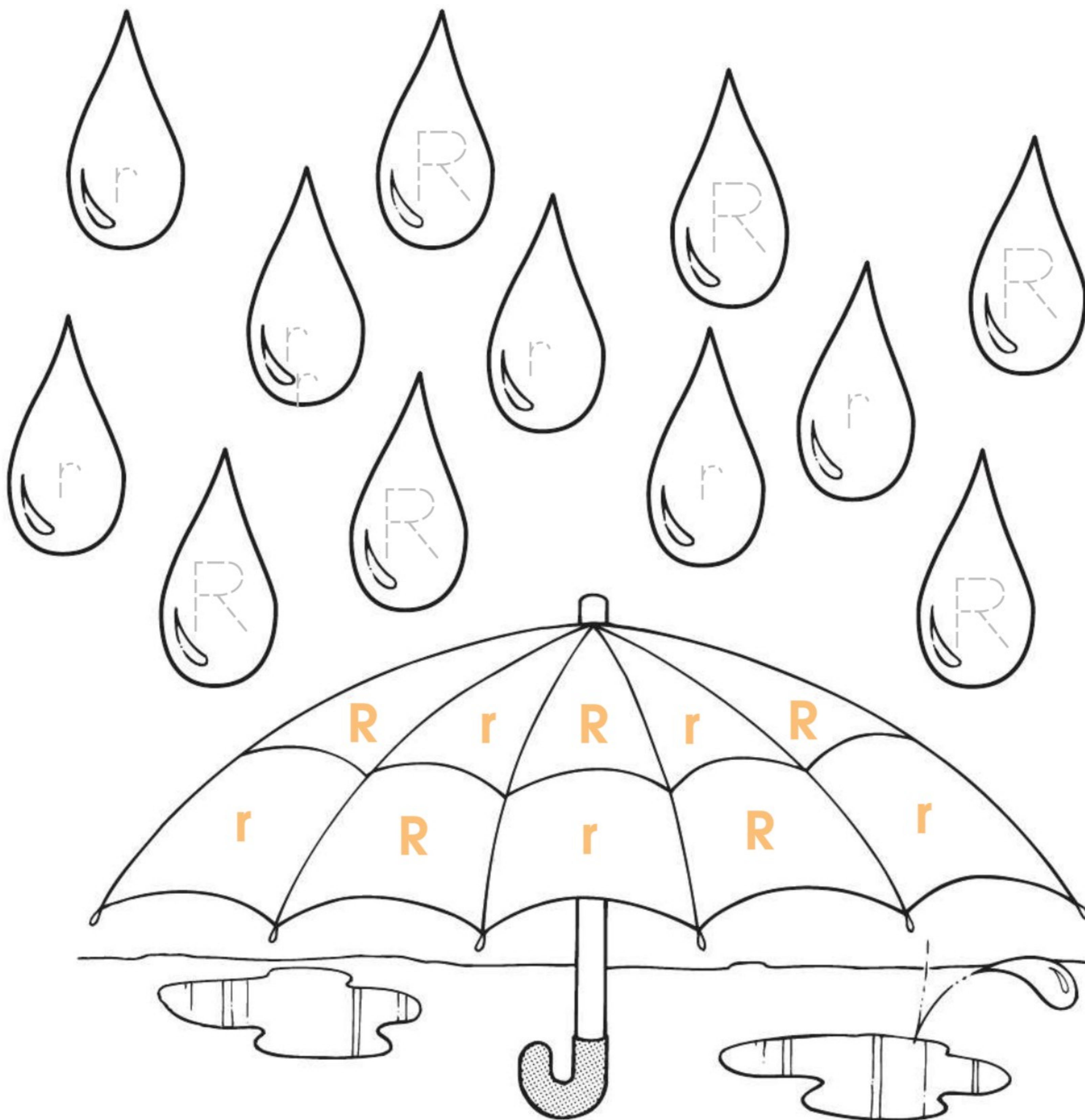



# Letter Rr

**Directions:** Circle  the **R** or **r** in these words:

rain

roses

Robert

rake

rabbit

Renee

**Directions:** Color  the pictures that start with the sound of **Rr**.

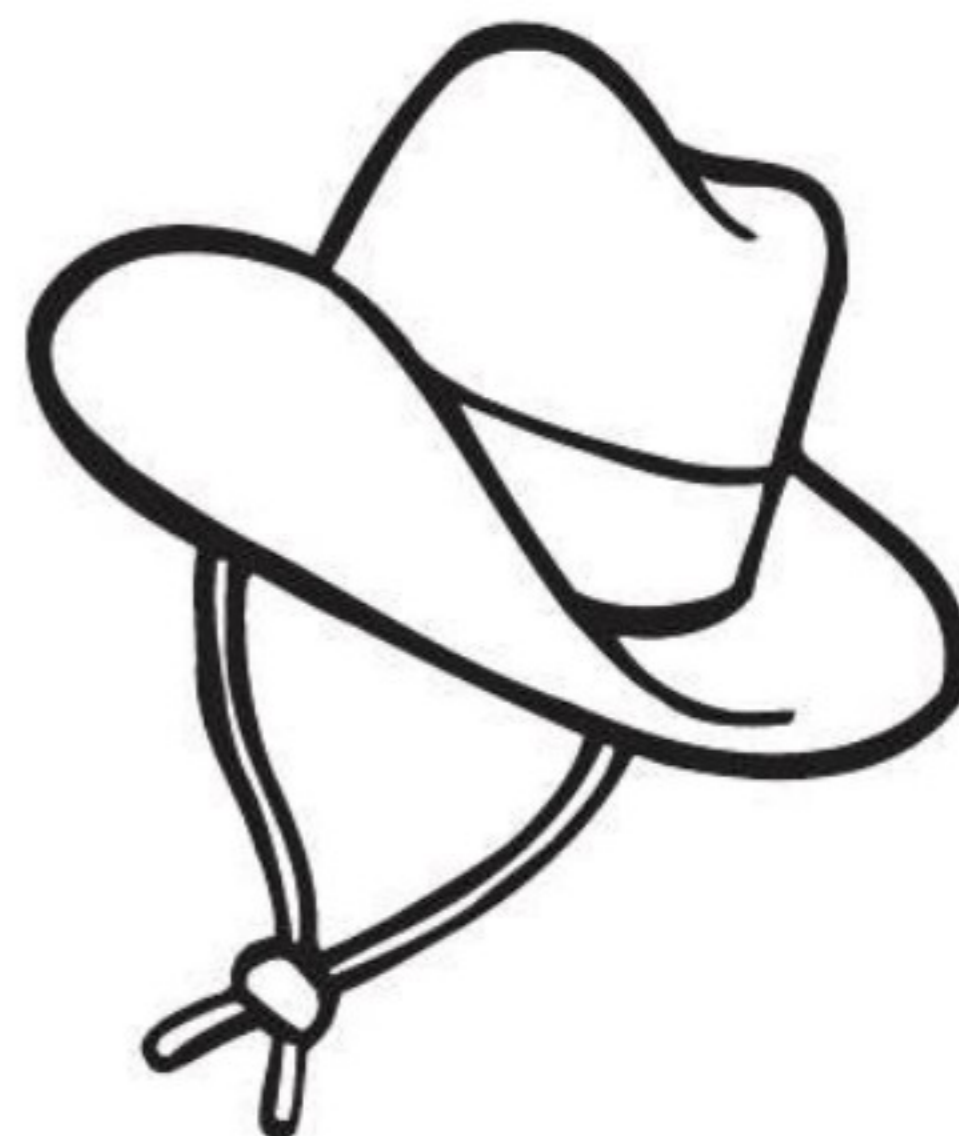
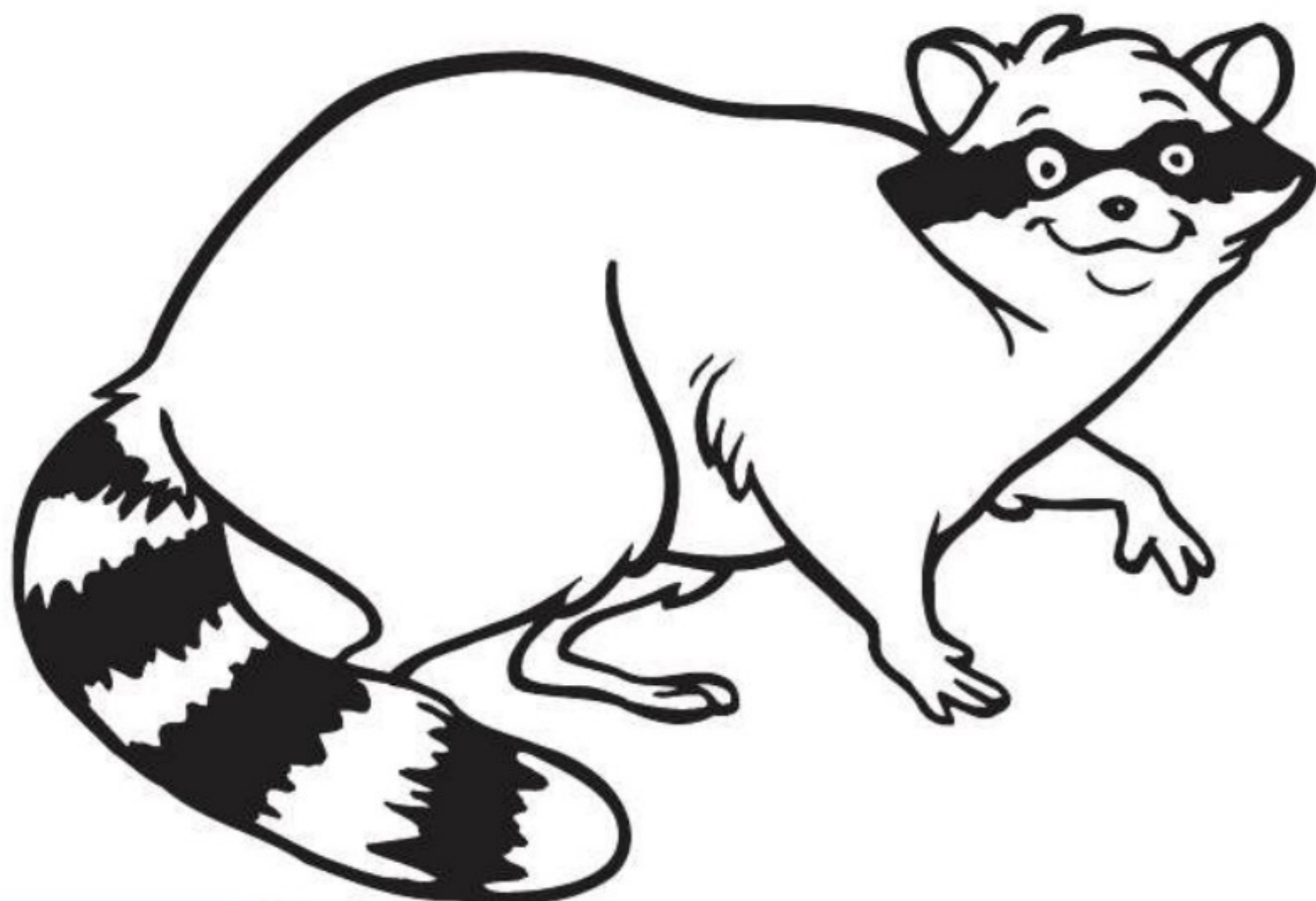
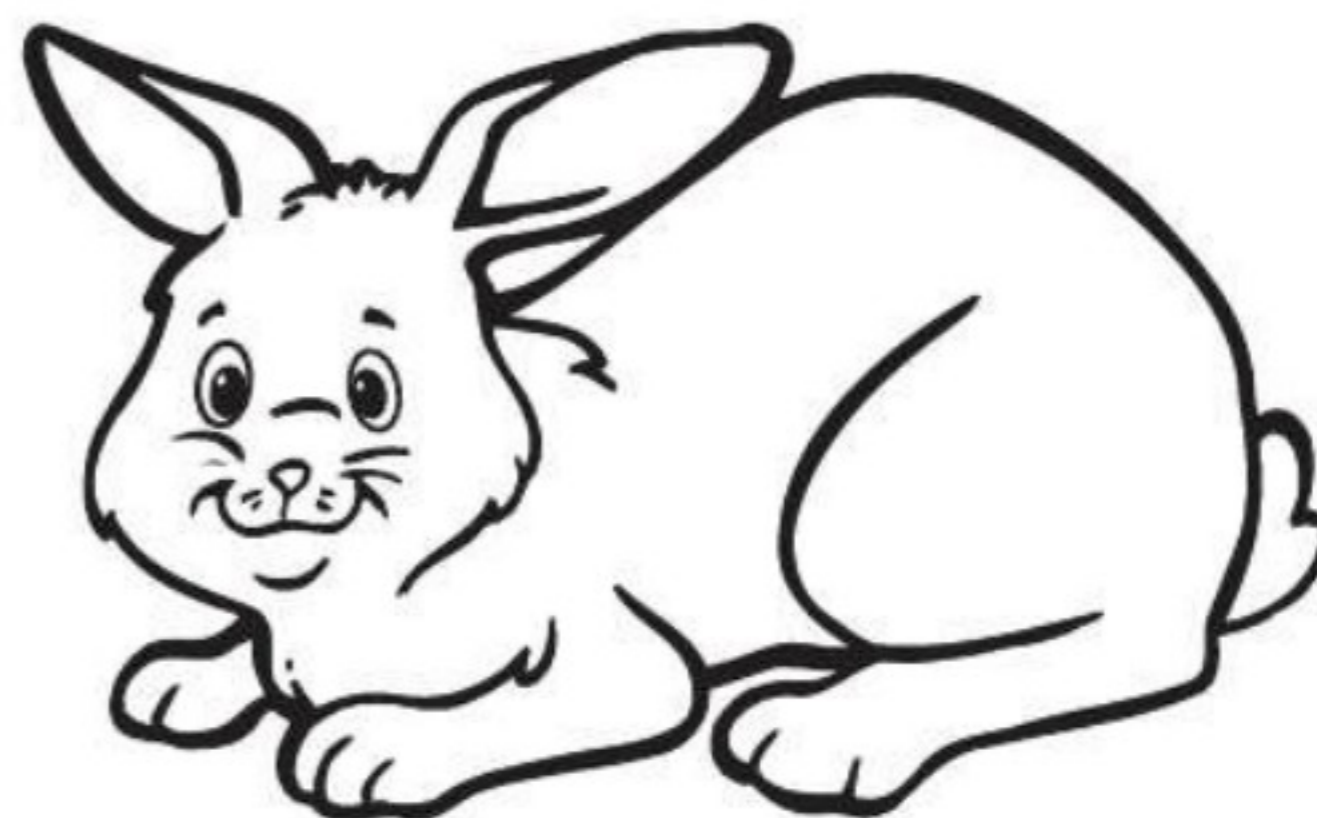
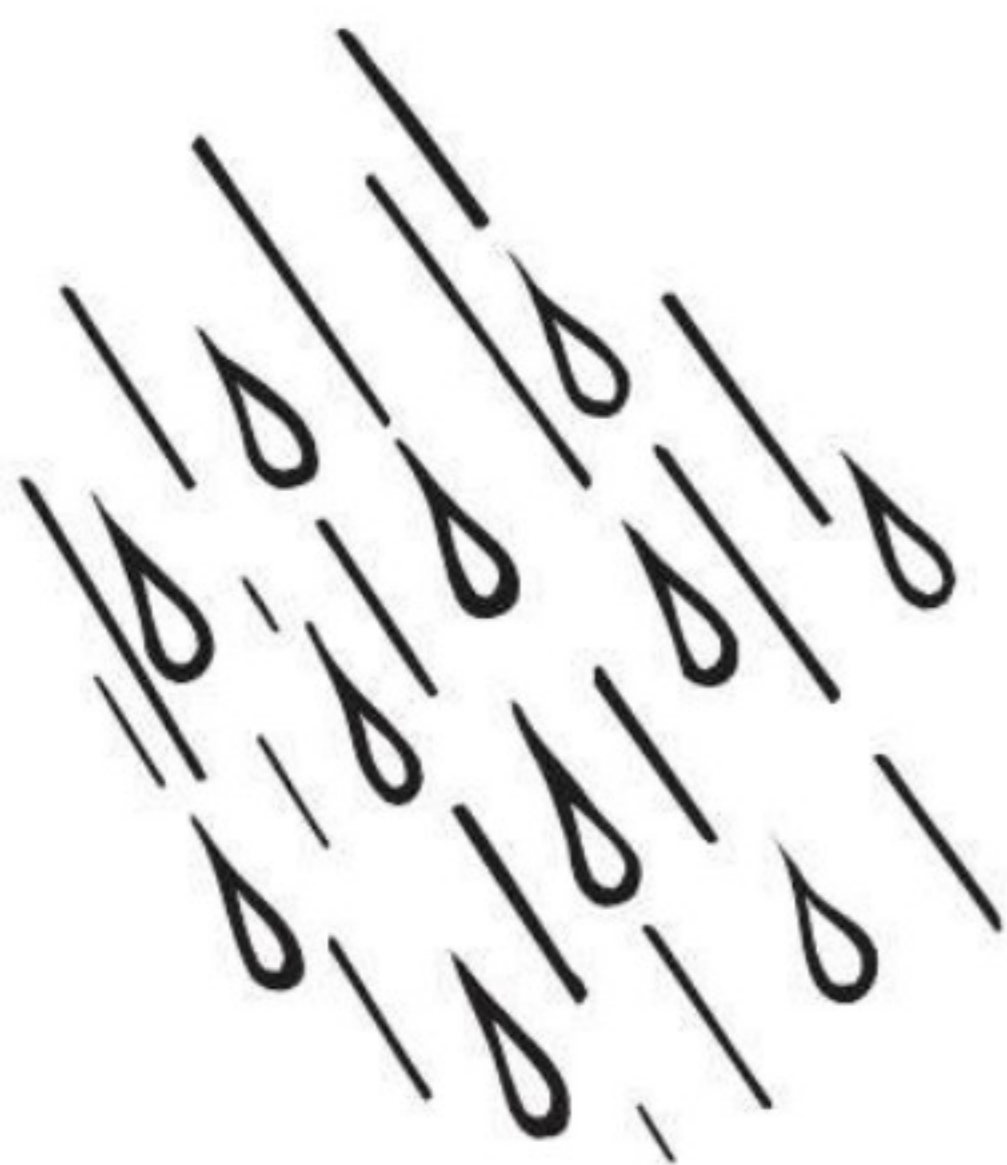



# Letter Rr

Help Rodeo Raccoon rope the **R**s.

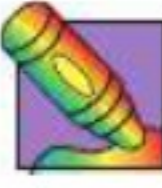
**Directions:** Circle  each picture that begins with the sound of **Rr**. Color  the picture with fun colors for Rodeo Raccoon!





# Letter Ss



**Directions:** Trace and write  the letter Ss.

UPPERCASE

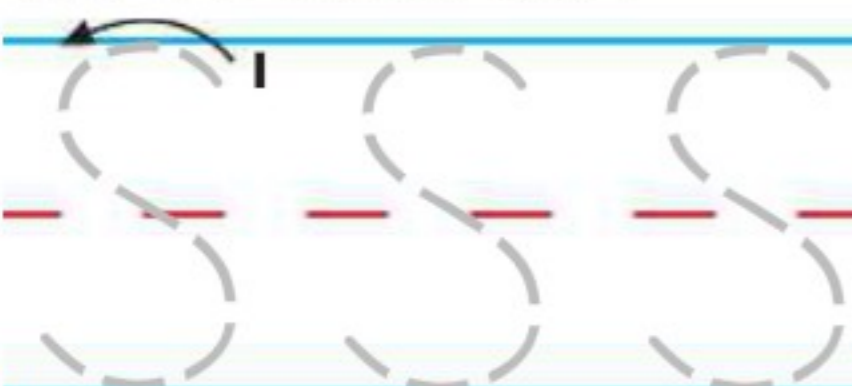

lowercase



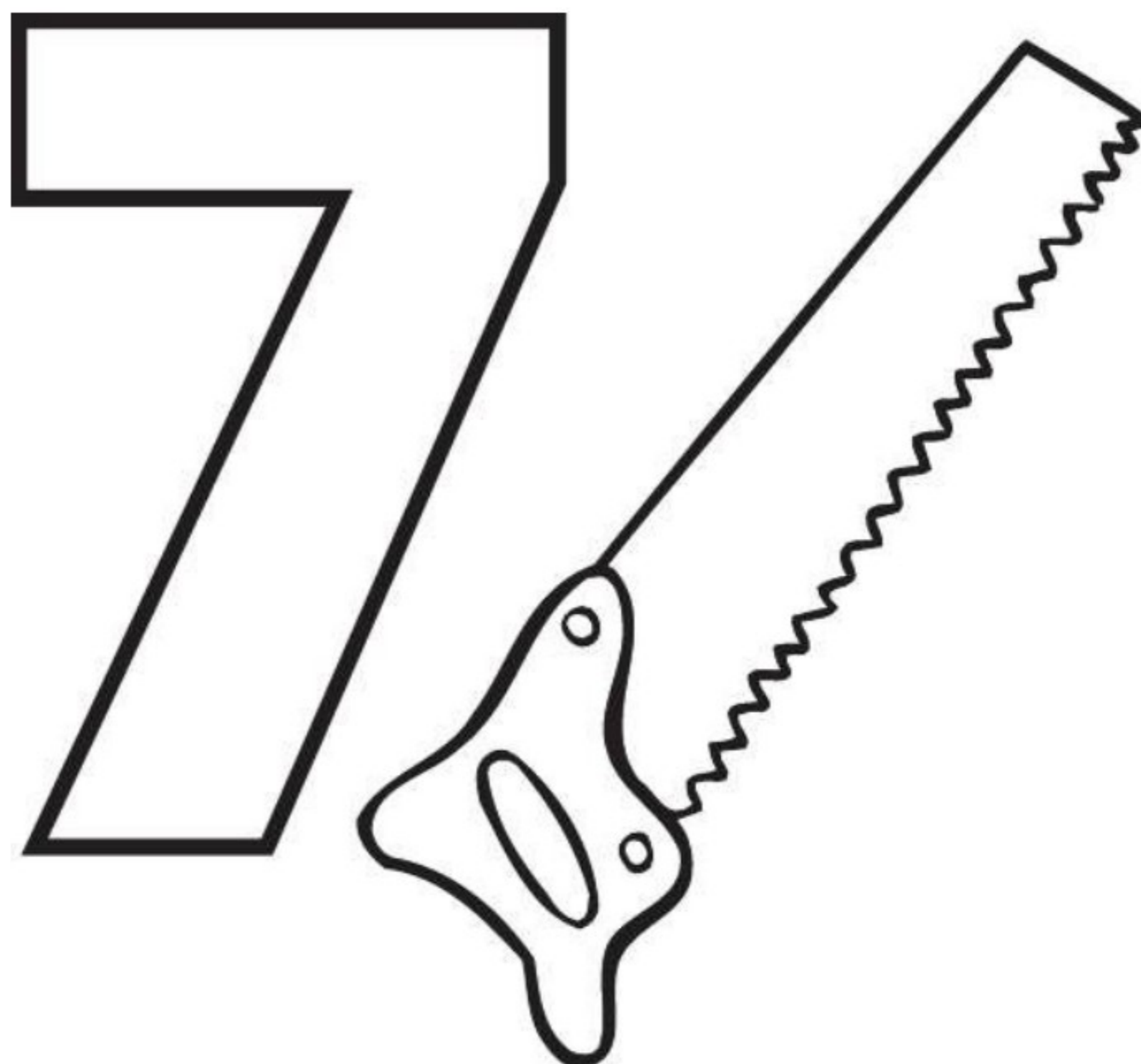
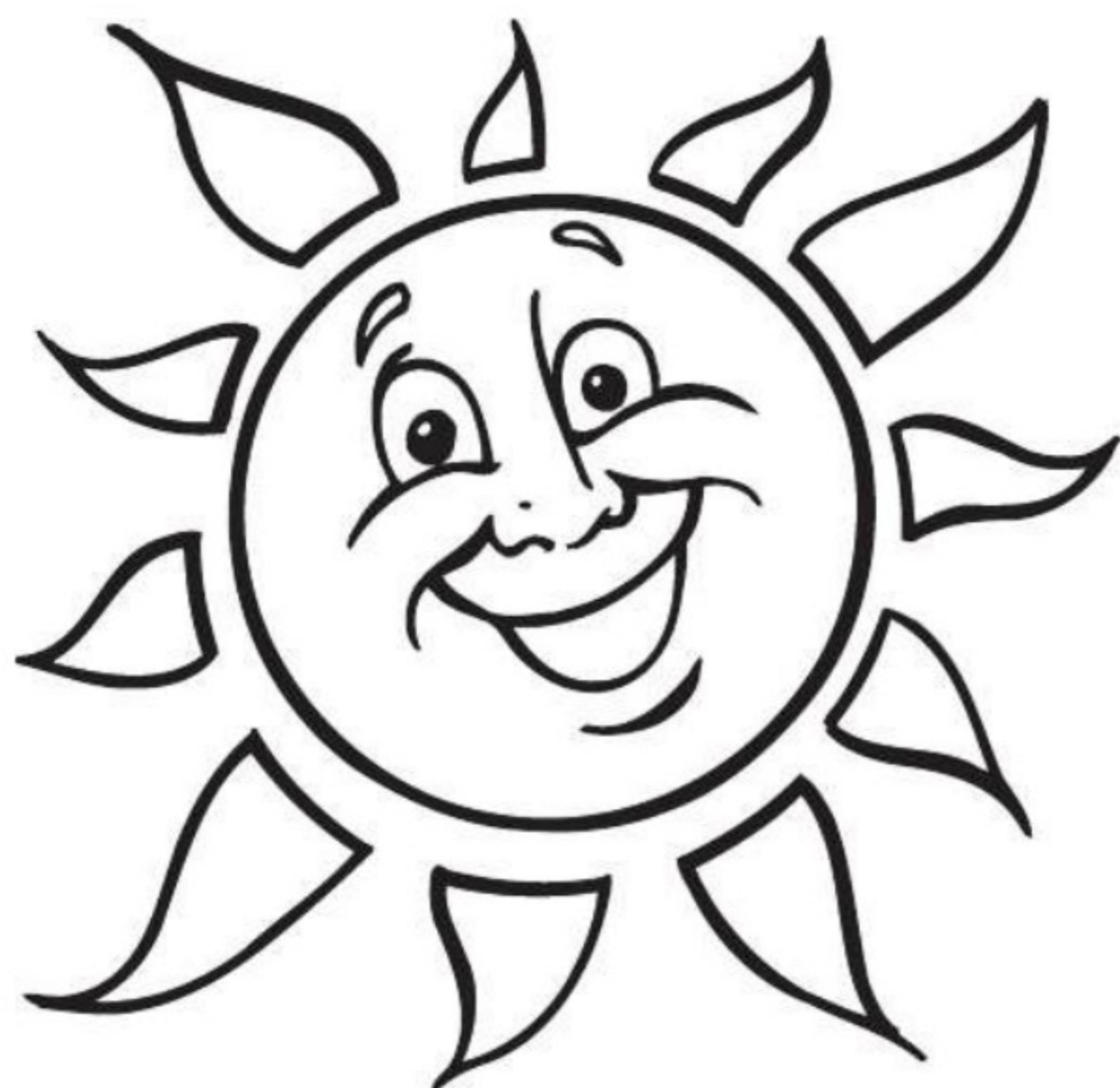

**Directions:** These pictures begin with the letter Ss.

**Color**  the pictures.





# Letter Ss

**Directions:** Trace  each **S** and **s**. Color  each bubble with **S yellow**. Color  each bubble with **s purple**.

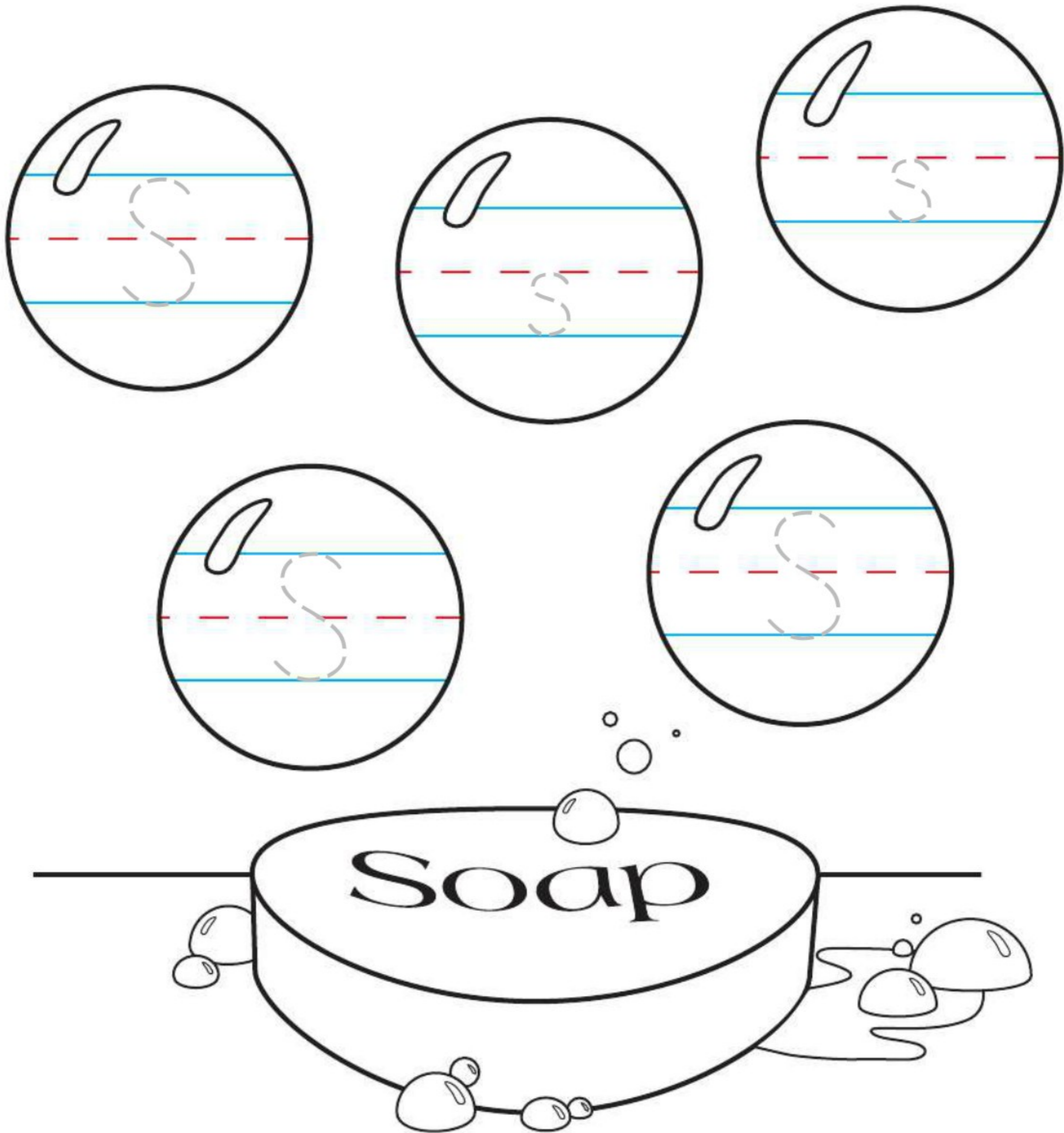



# Letter Ss

**Directions:** Circle  the **S** or **s** in these words:

sun

see

six

Sam

sailboat

Susie

**Directions:** Color  the pictures that start with the sound of **Ss**.

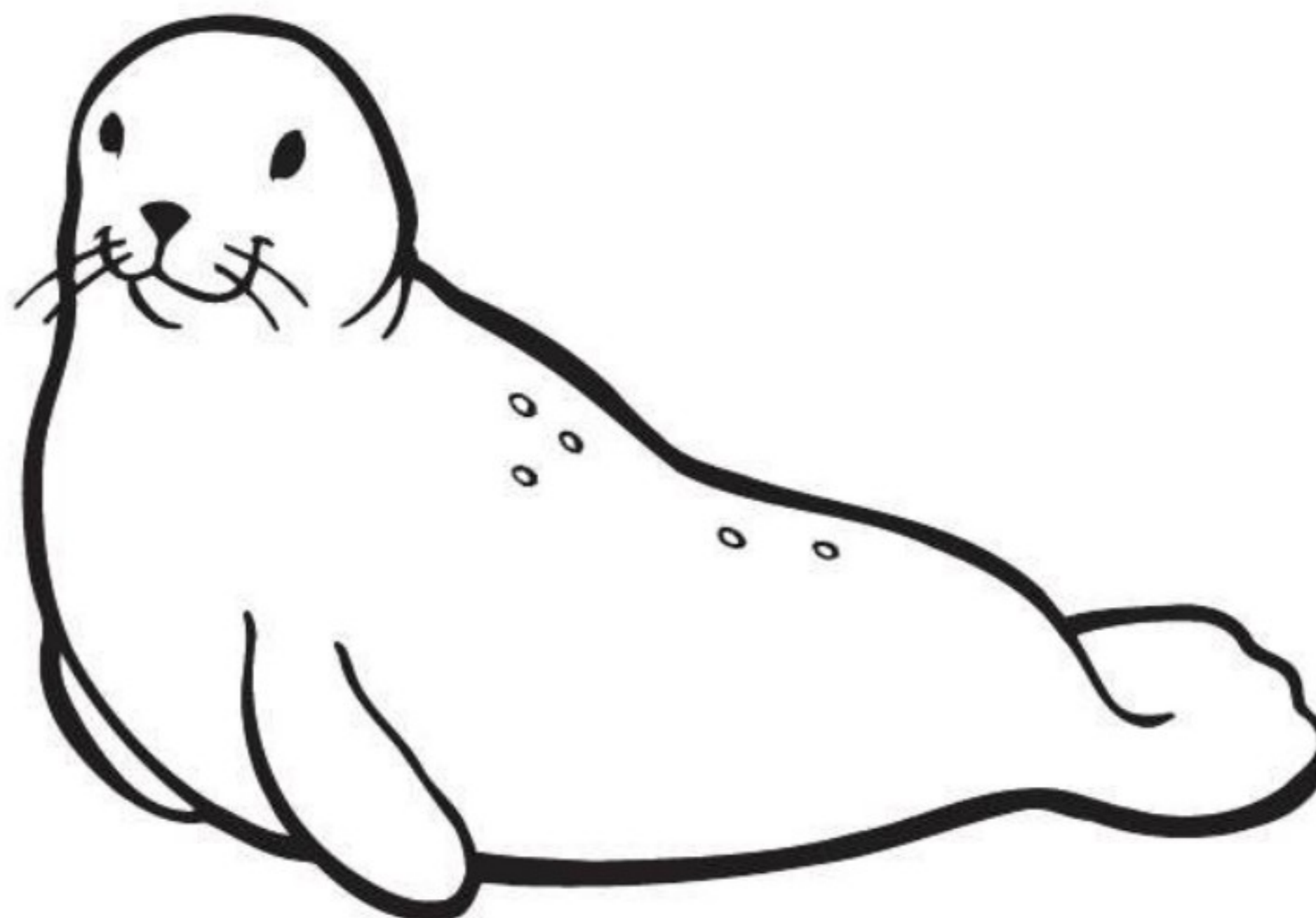
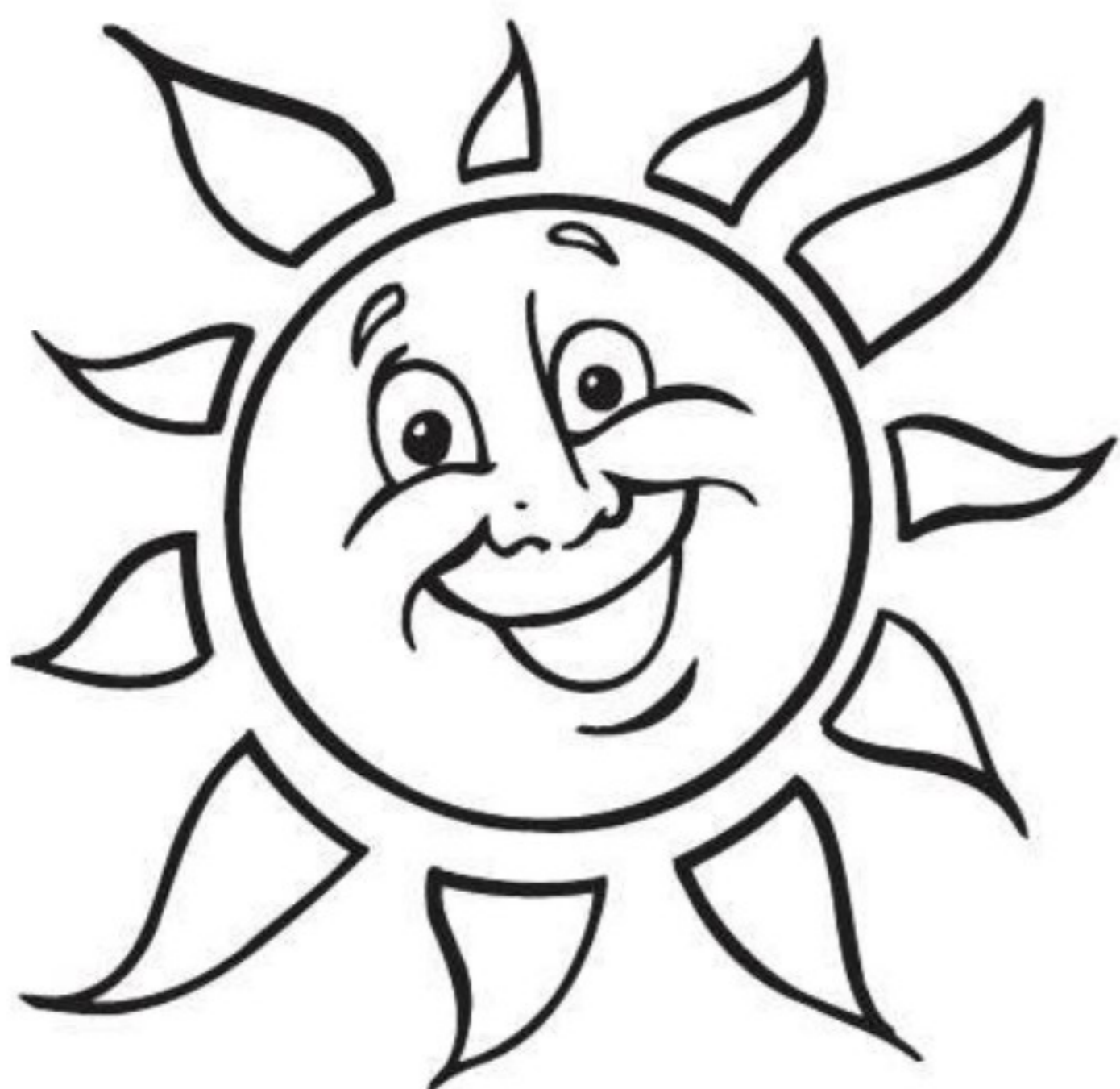
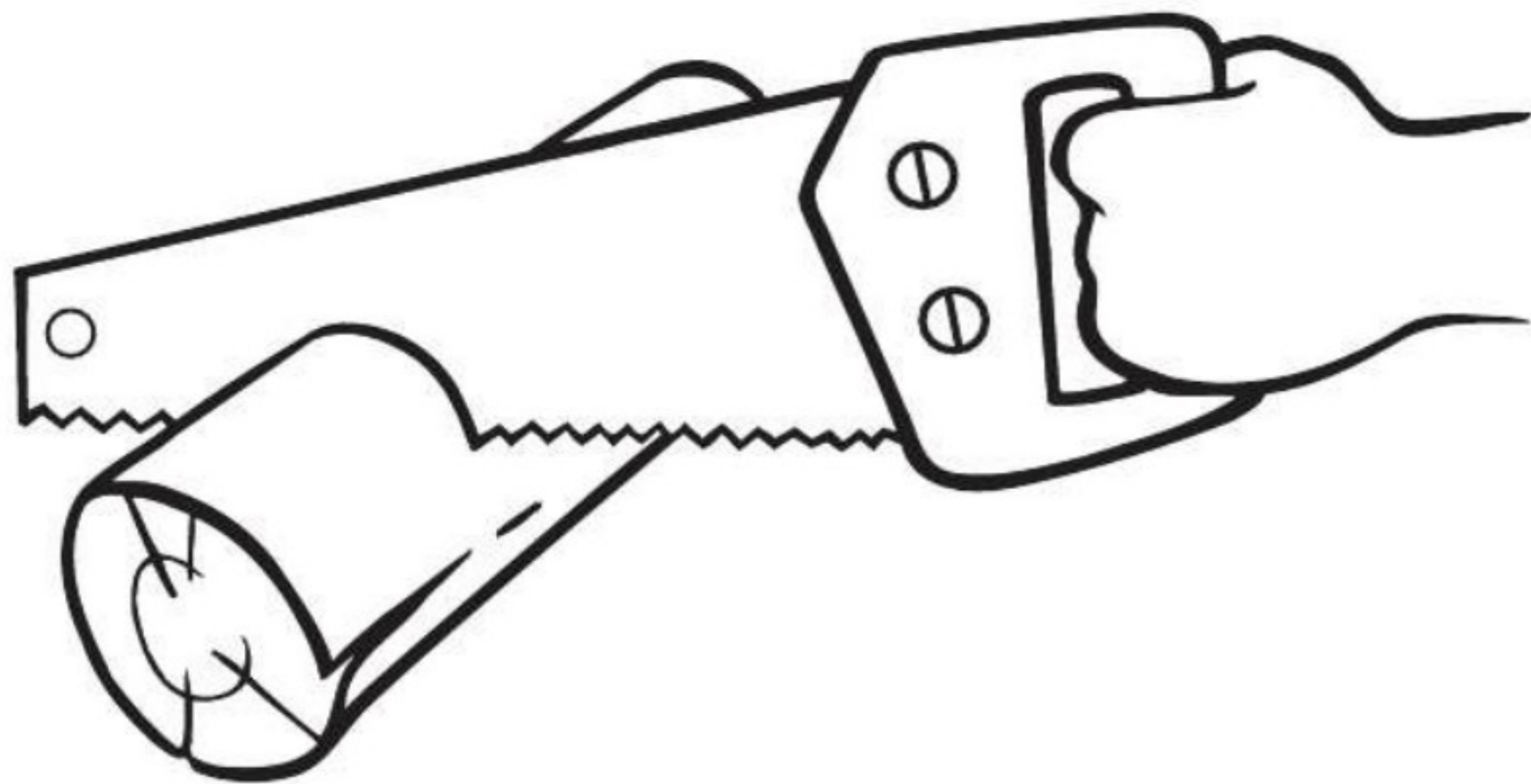





# Letter Ss

These words start with **S** or **s**.

**Directions:** Write  a lowercase **s** on each line.

**Color**  the pictures.

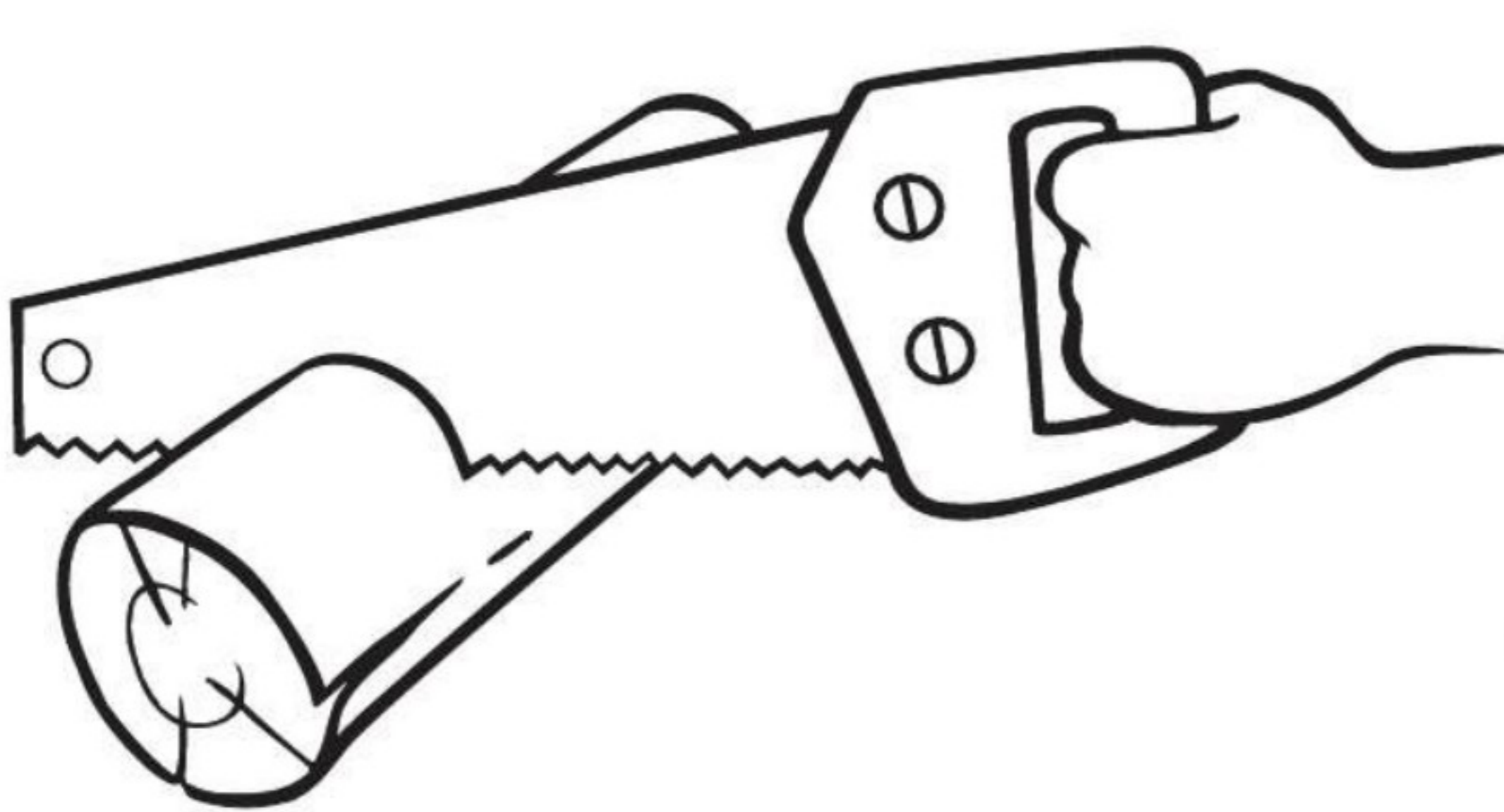

S is for       aw.

S is for       un.

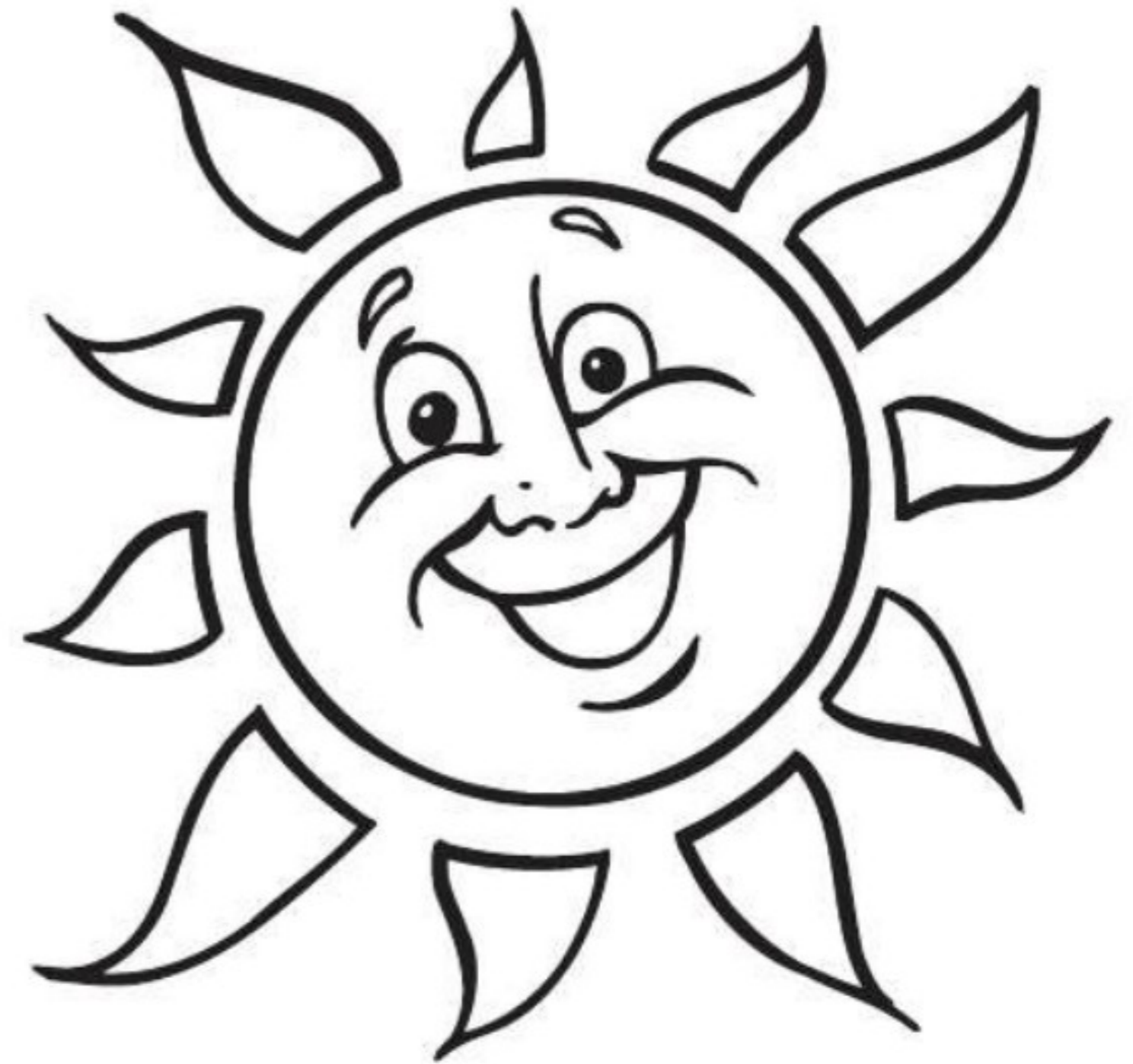

S is for       nake.



# Letter Tt

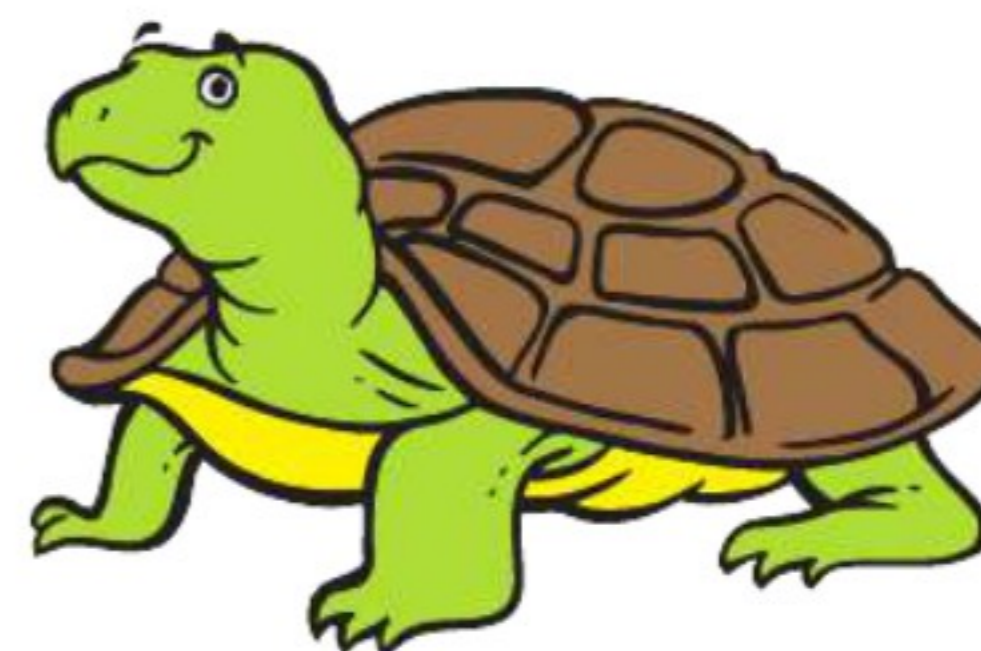

**Directions:** Trace and write  the letter Tt.

UPPERCASE



lowercase



**Directions:** These pictures begin with the letter Tt.

**Color**  the pictures.

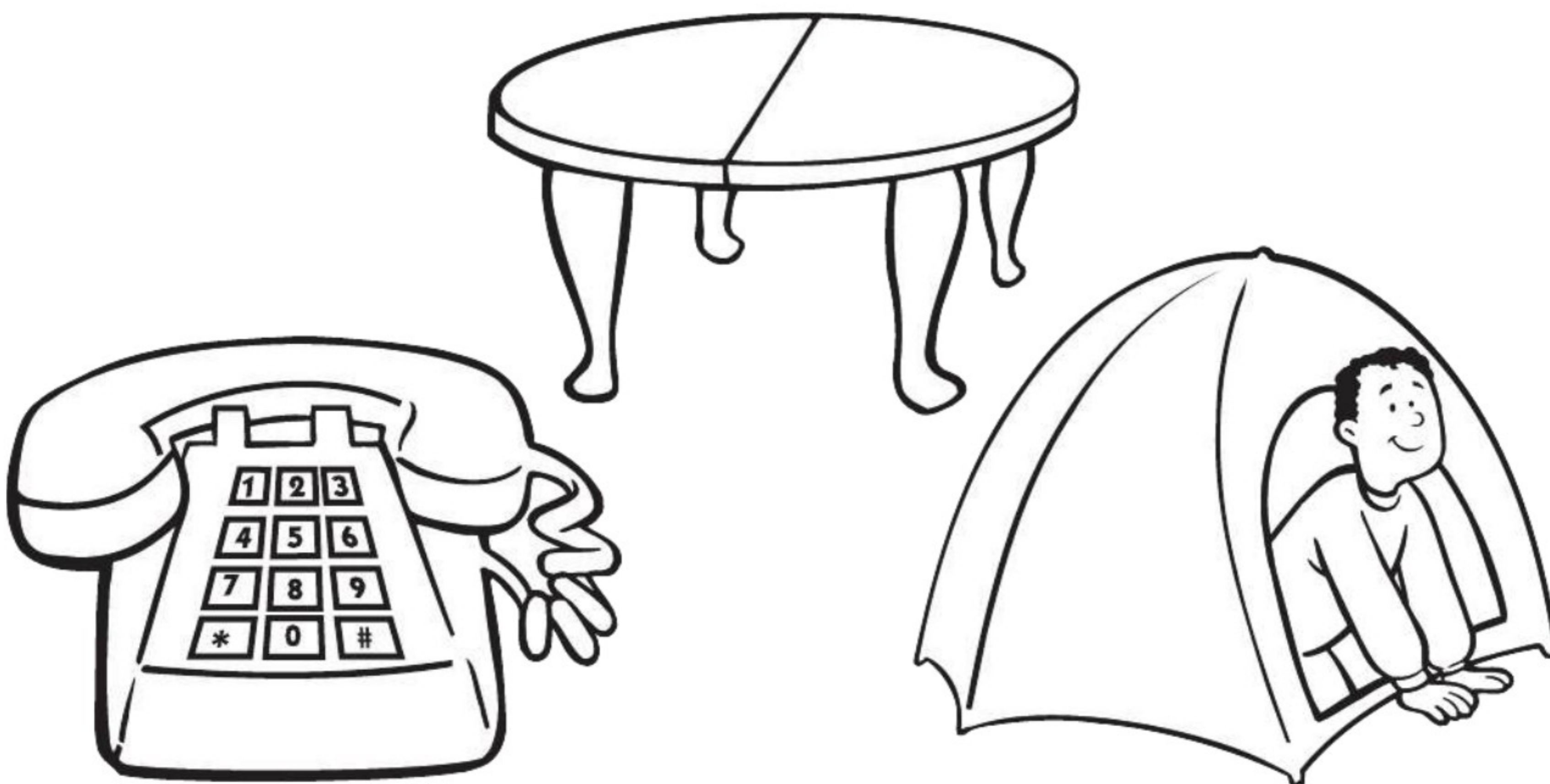



# Letter Tt

Do you like to play tic-tac-toe?

**Directions:** Color  each **T** and **t** with the correct color.

**Draw**  a line to win tic-tac-toe.

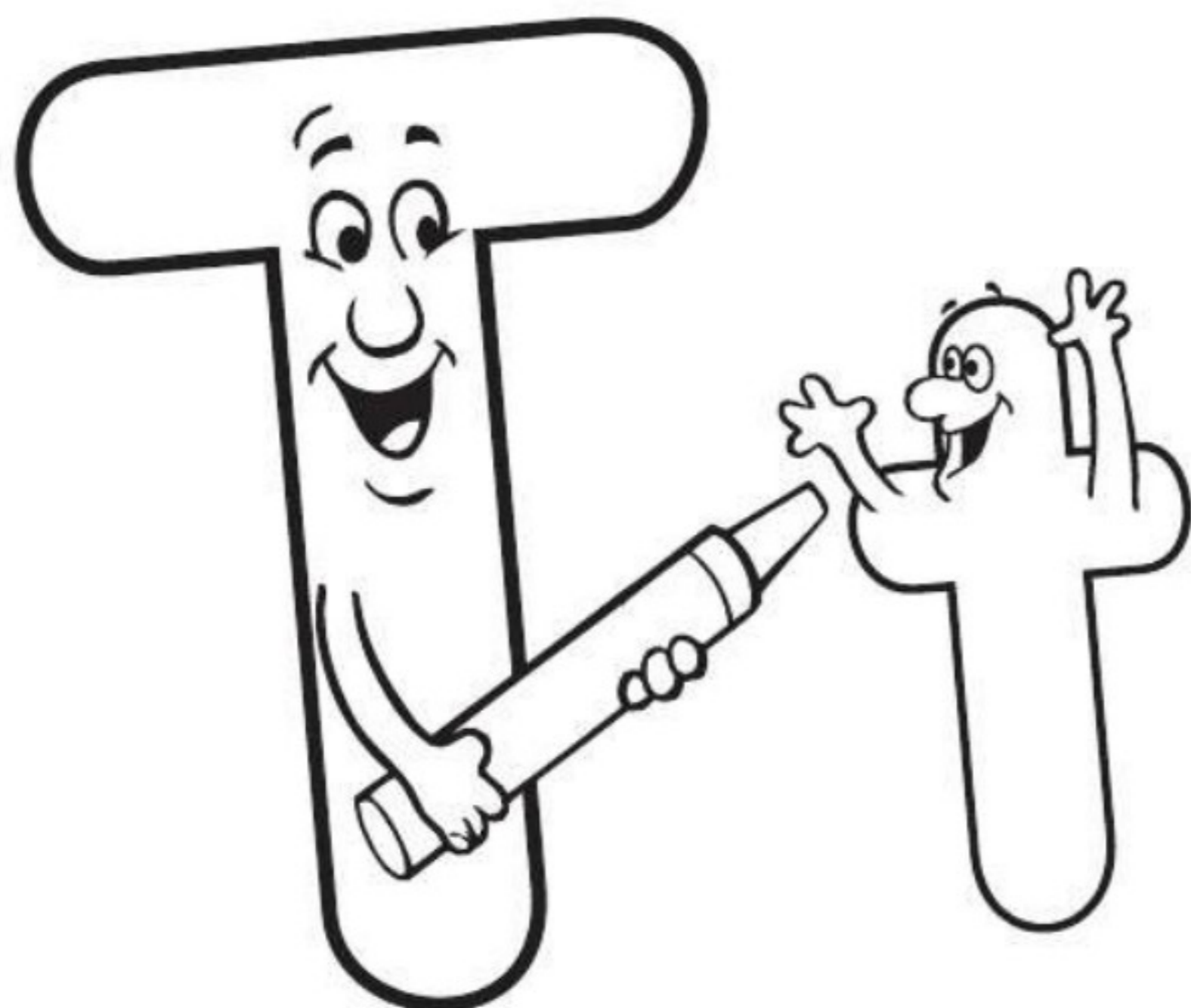

**T = blue**  
**t = yellow**

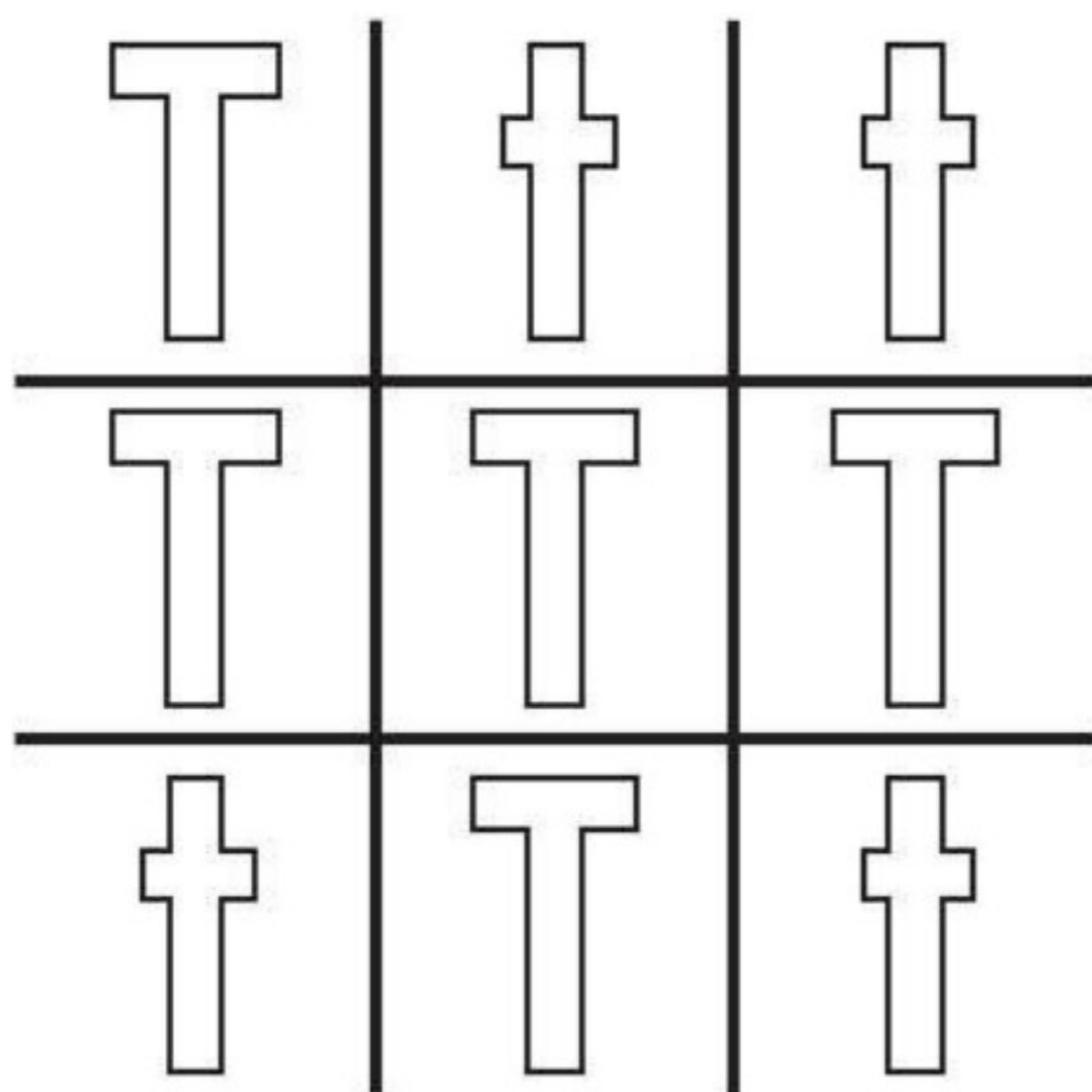

**T = red**  
**t = green**

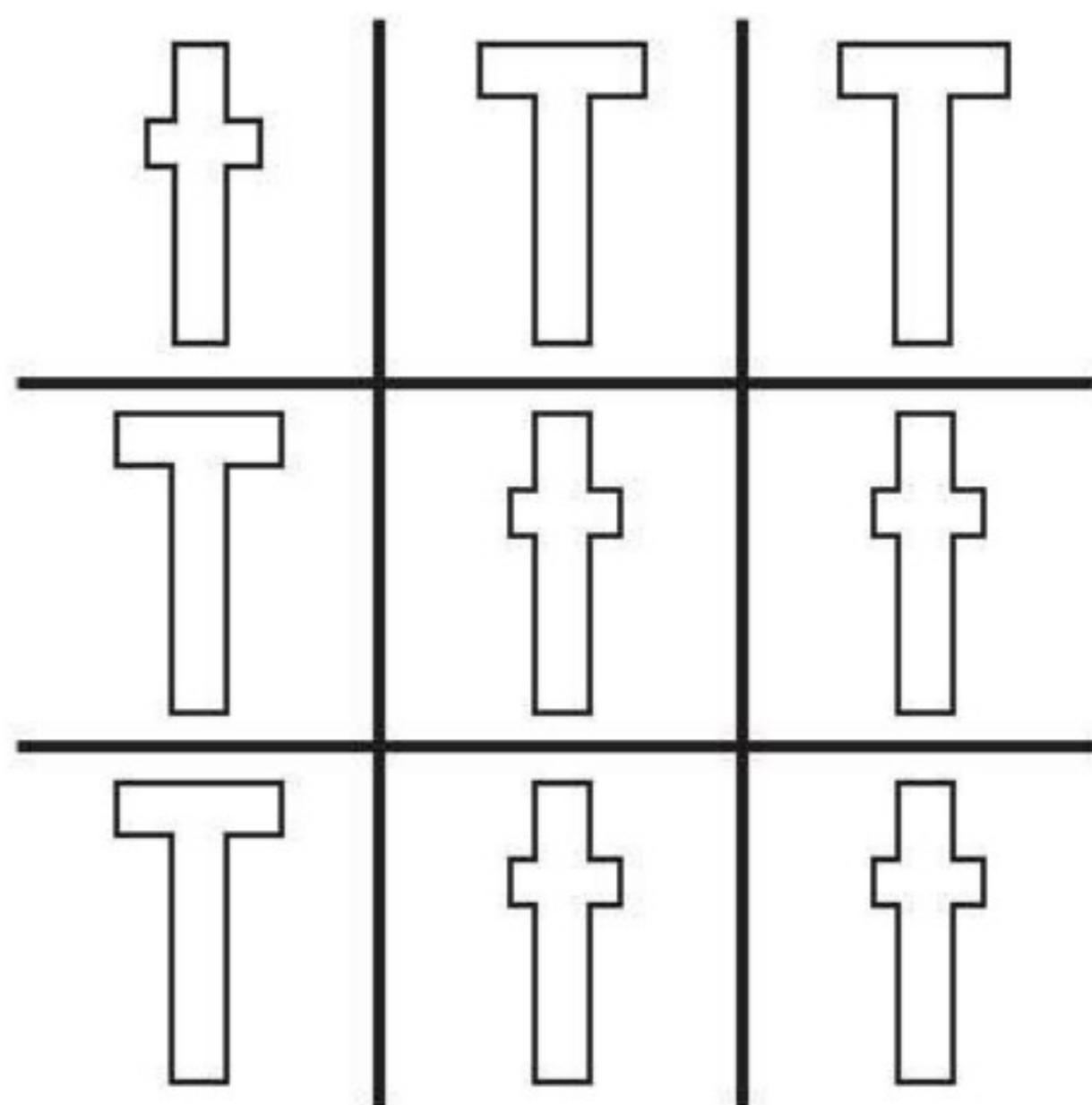

**T = purple**  
**t = orange**

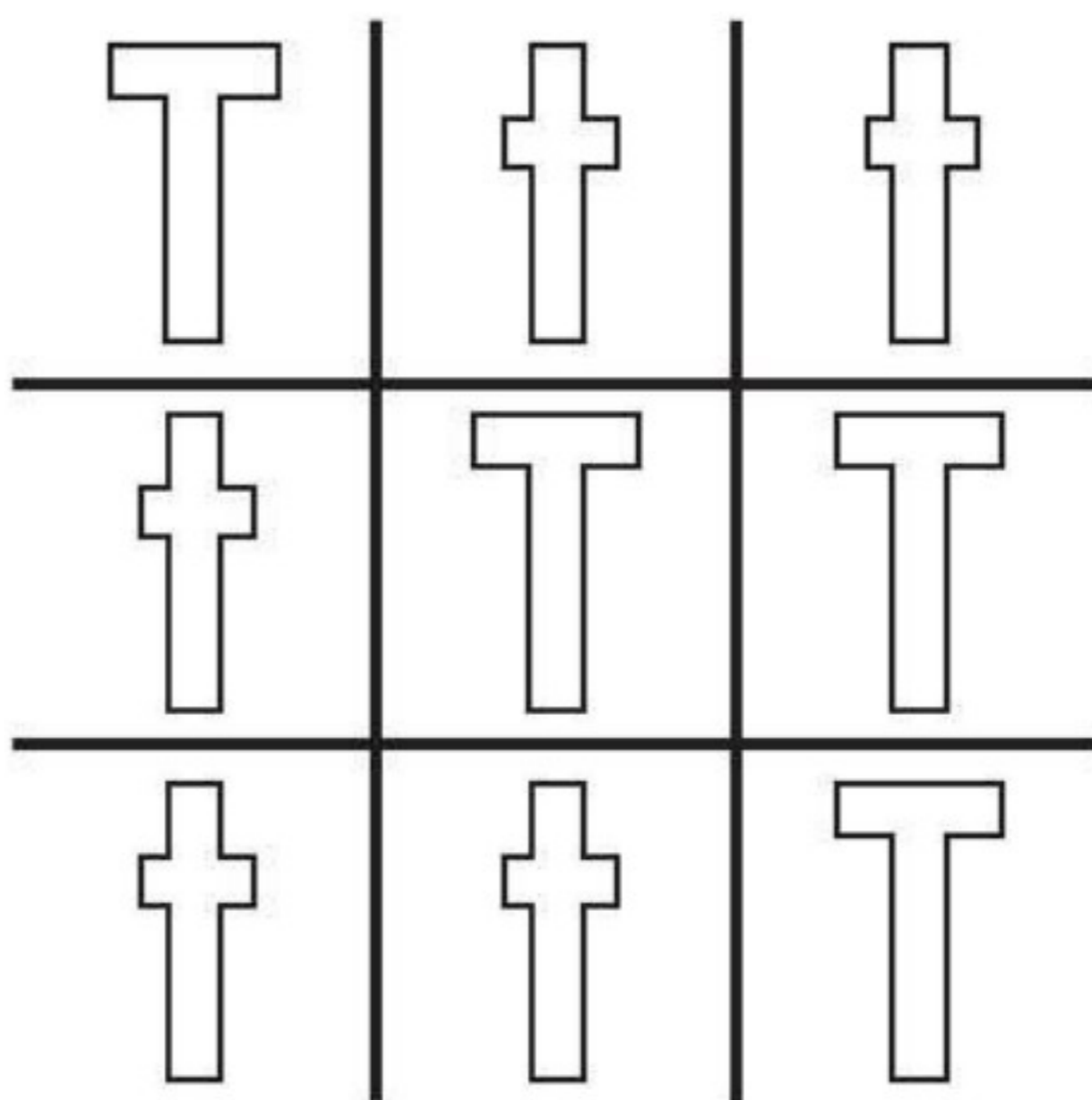



# Letter Tt

**Directions:** Circle  the **T** or **t** in these words:

Taylor

table

tiger

Timothy

two

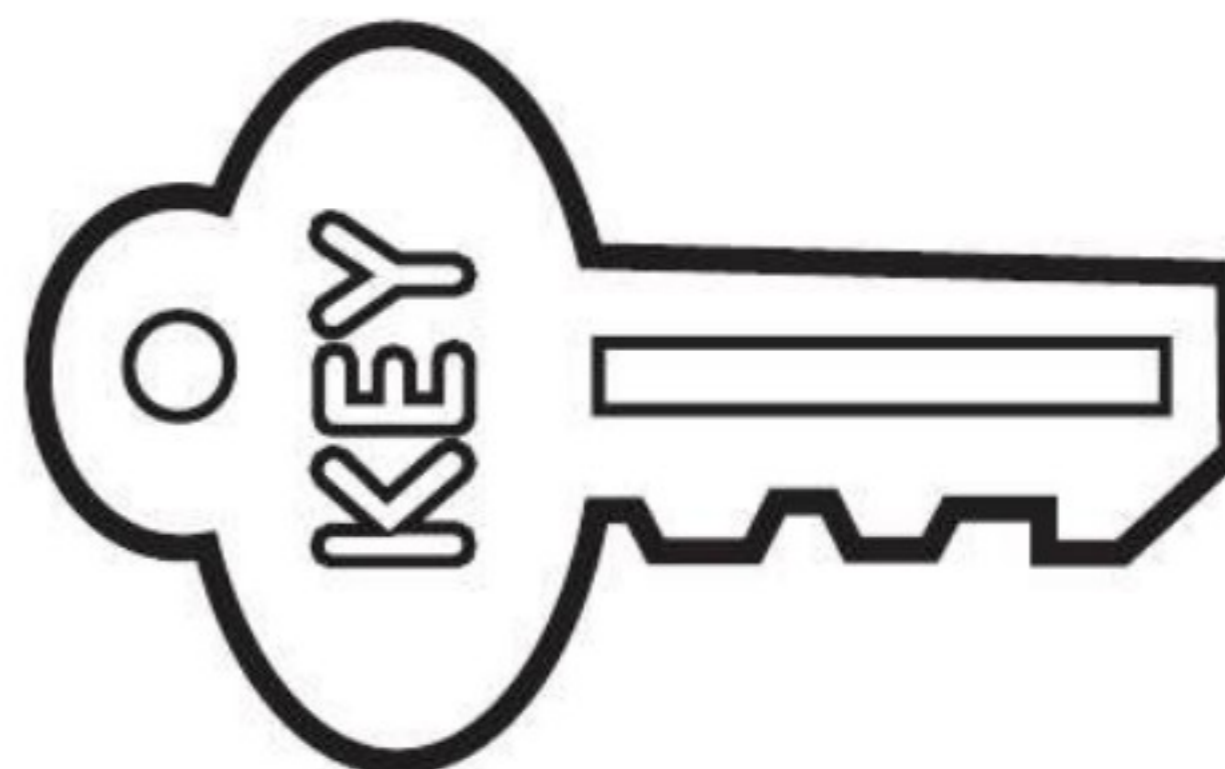
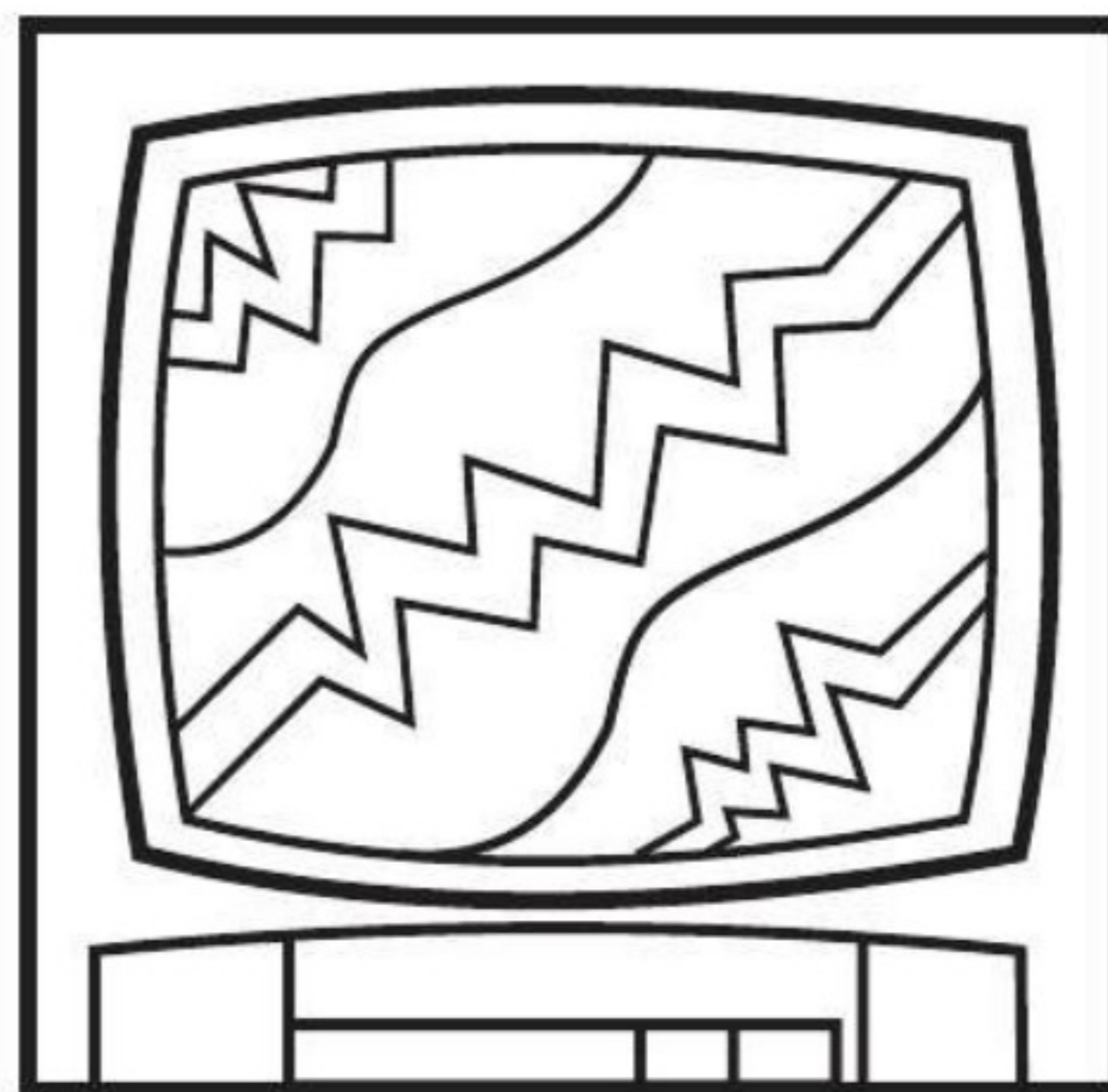
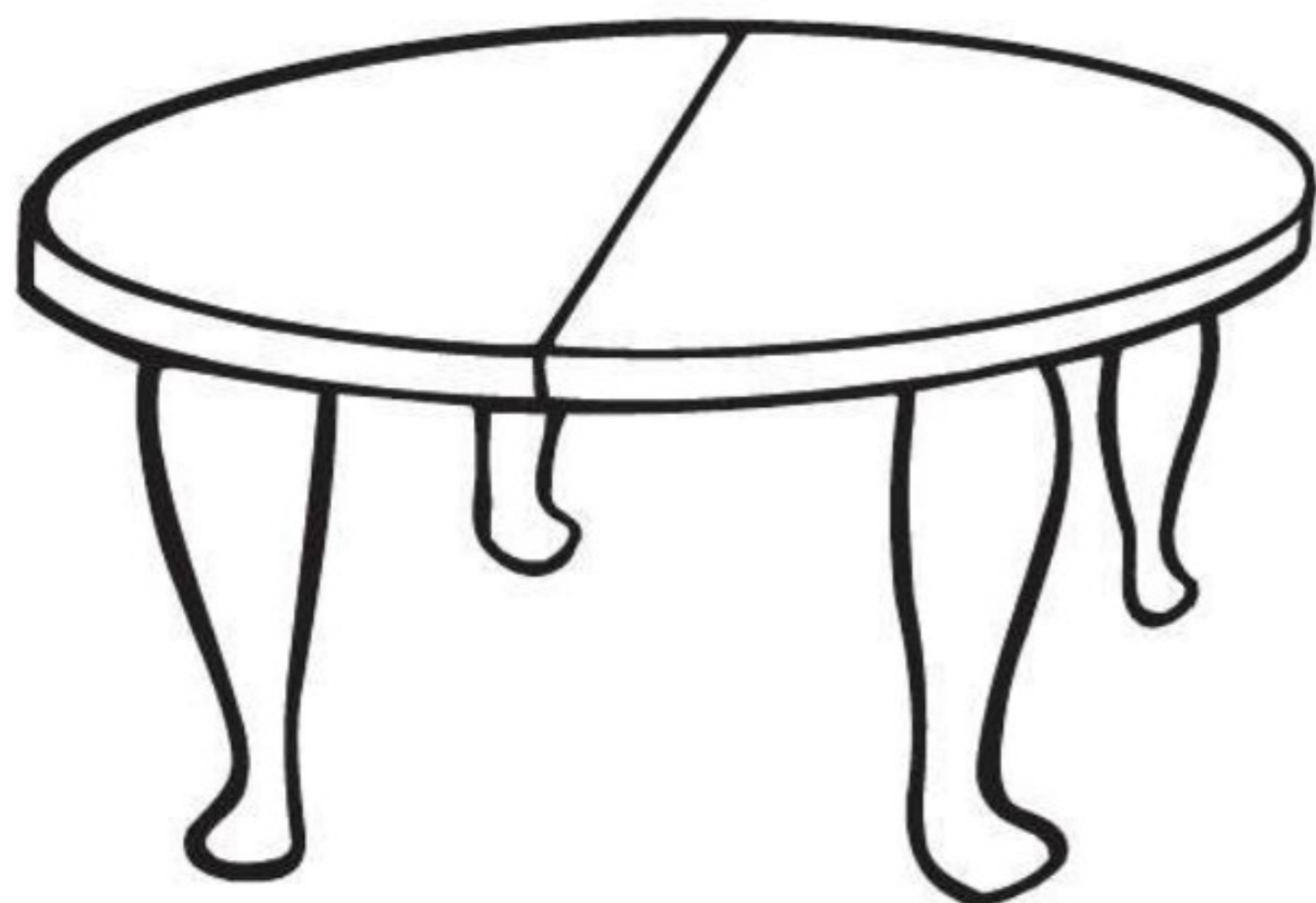

television

**Directions:** Color  the pictures that start with the sound of **Tt**.



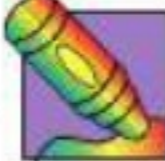

# Letter Tt

**Directions:** Color  the pictures that begin with the sound of **Tt** **orange**. Then, **color**  the rest of the picture with bright colors.

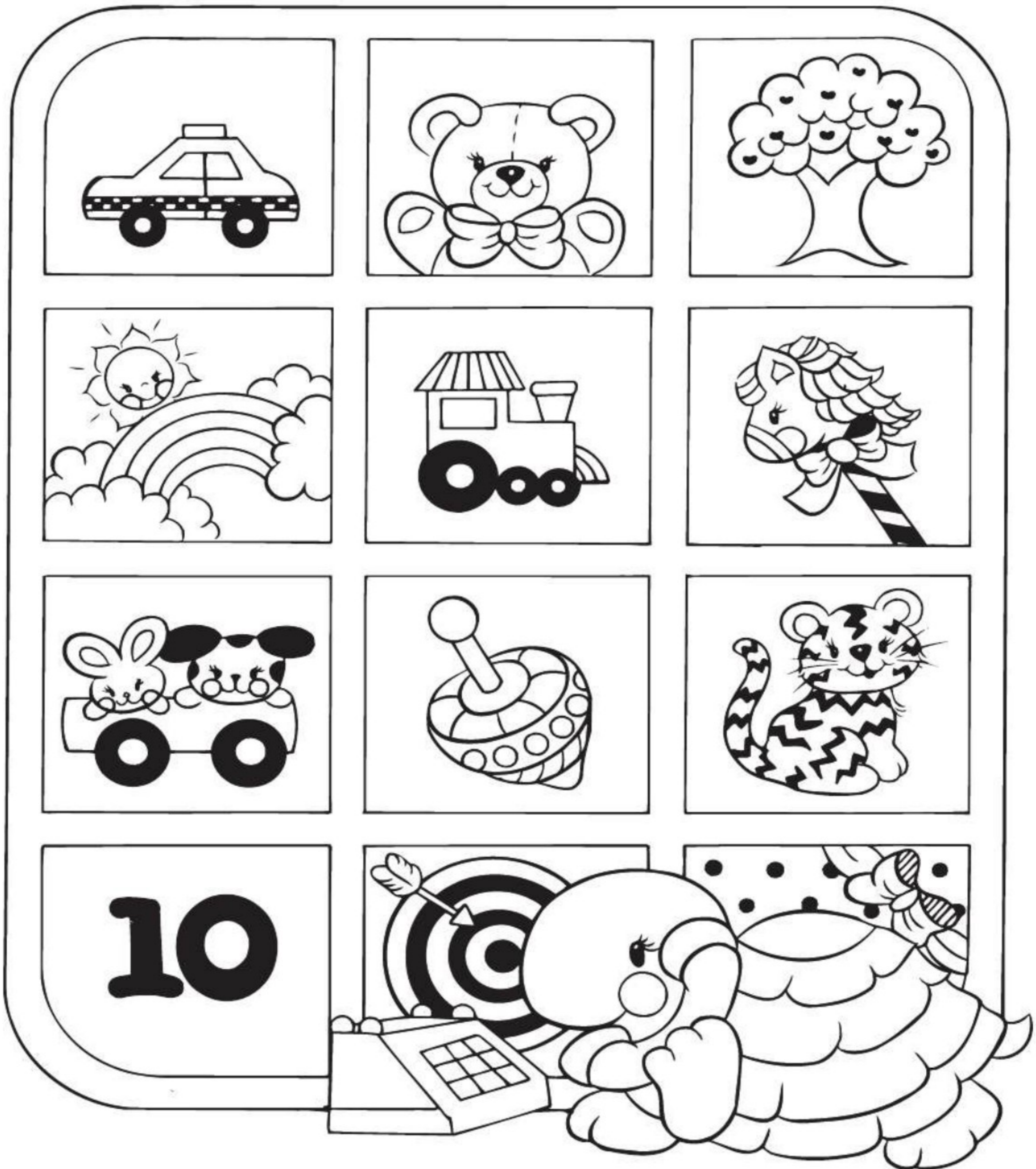



# Letter Uu



**Directions:** Trace and write  the letter **Uu**.

UPPERCASE



lowercase



**Directions:** These pictures begin with the letter **Uu**.

**Color**  the pictures.





# Letter Uu

Find each hidden **U** and **u**.

**Directions:** Color  each **U** purple. Color  each **u** orange. Then, color  the rest of the picture.

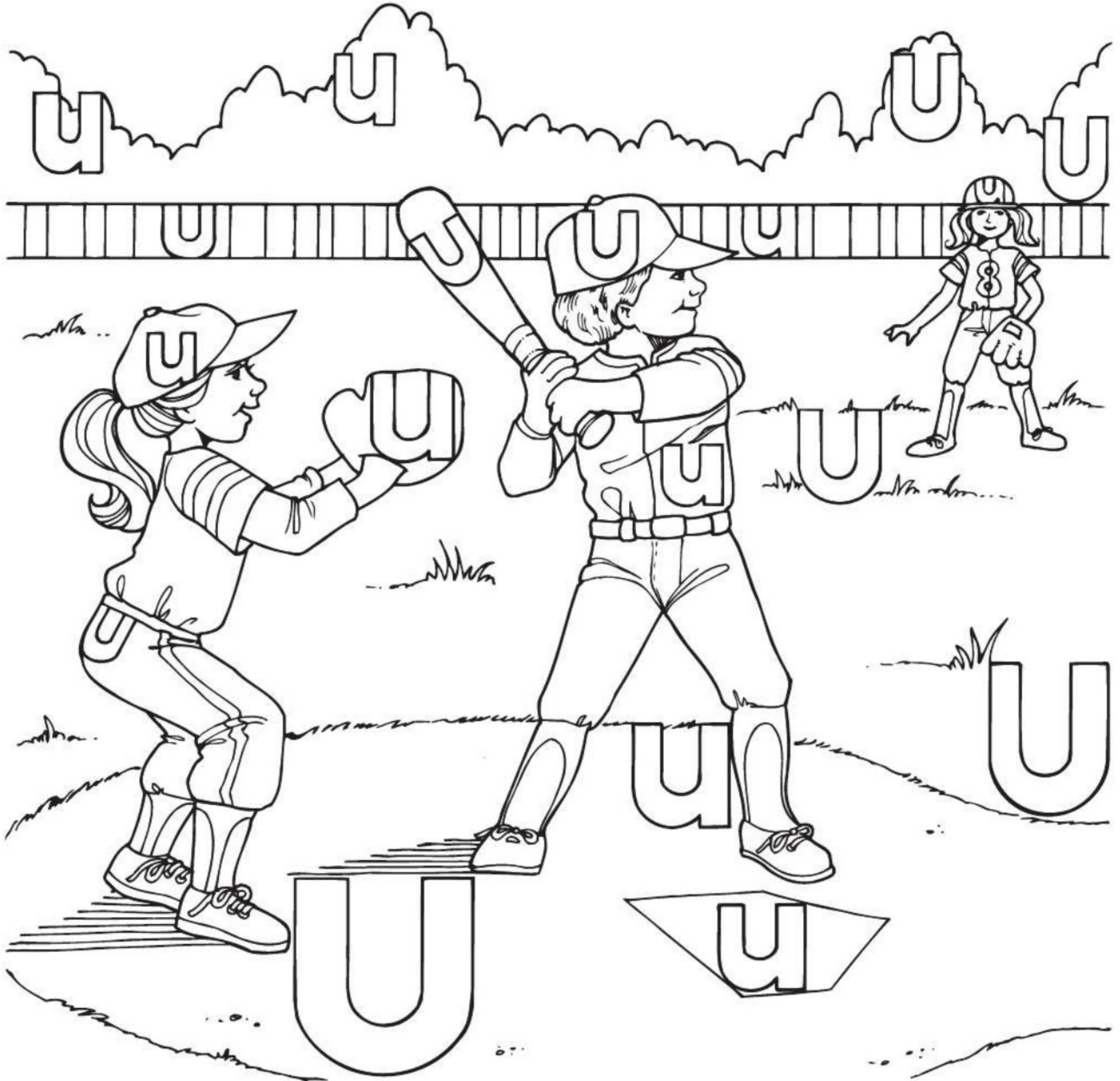



# Letter Uu

**Directions:** Circle  the **U** or **u** in these words:

under

unicorn

unless

umbrella

up

use

**Directions:** The letter **Uu** can have more than one sound.

**Color**  the pictures that start with the sound of **Uu**.

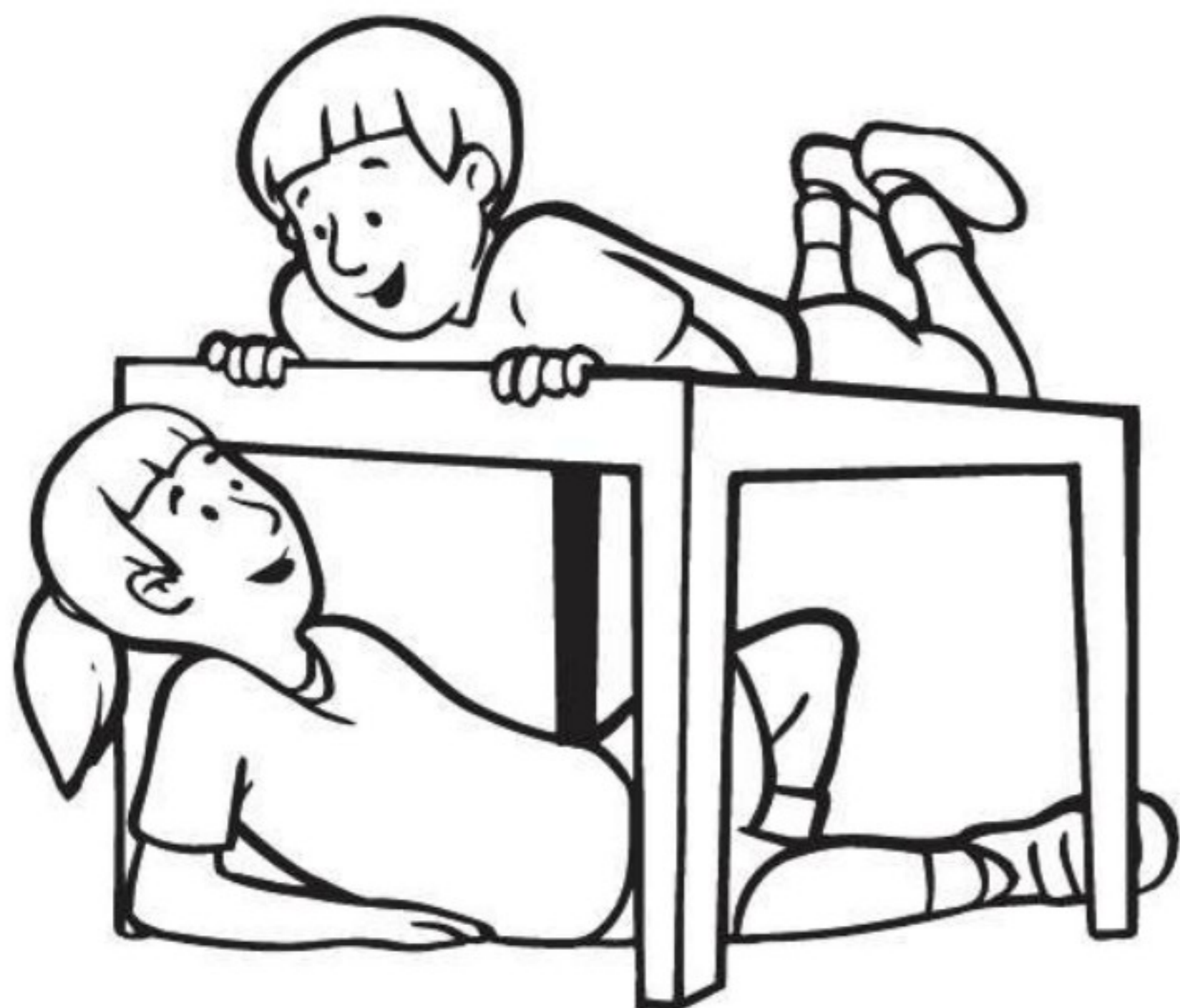
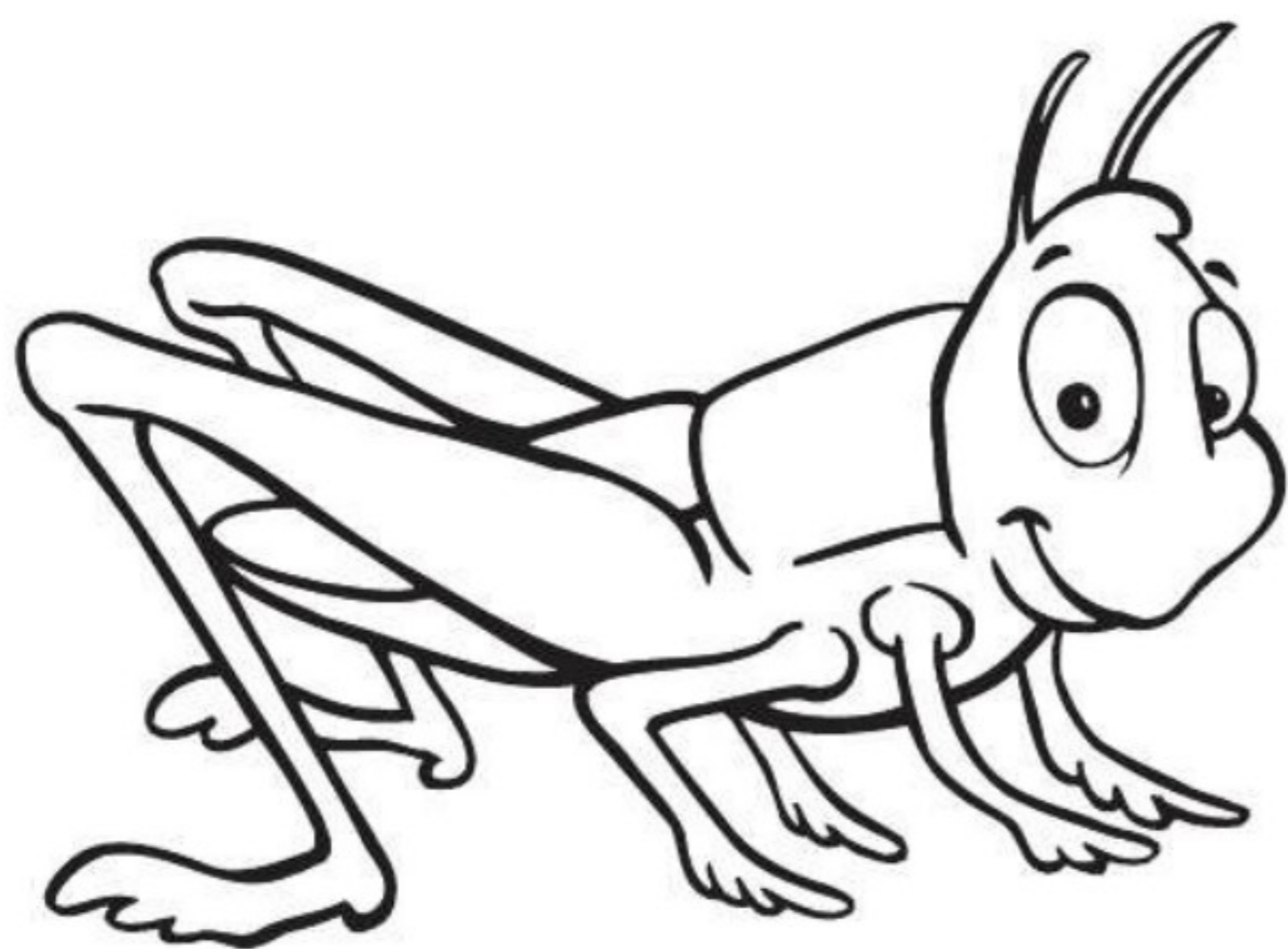





# Letter Uu

These words start with **U** or **u**.

**Directions:** Write  a lowercase **u** on each line.

**Color**  the pictures.



U is for \_\_\_\_\_ unicorn.



U is for \_\_\_\_\_ p.



U is for \_\_\_\_\_ mbrella.





# Letter Vv



**Directions:** Trace and write  the letter Vv.

UPPERCASE



lowercase





**Directions:** These pictures begin with the letter Vv.

**Color**  the pictures.





# Letter Vv

**Directions:** Trace  each **V** and **v**. Color  each heart with **V** or **v** red. Draw  a line from each **V** or **v** to one of the hearts on the left.

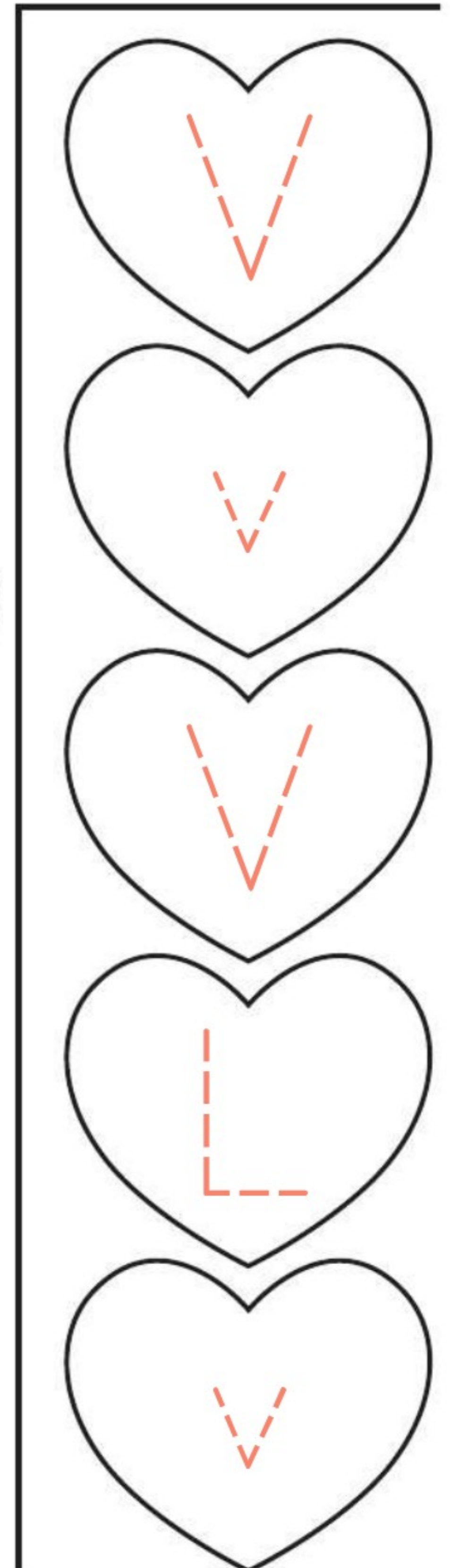
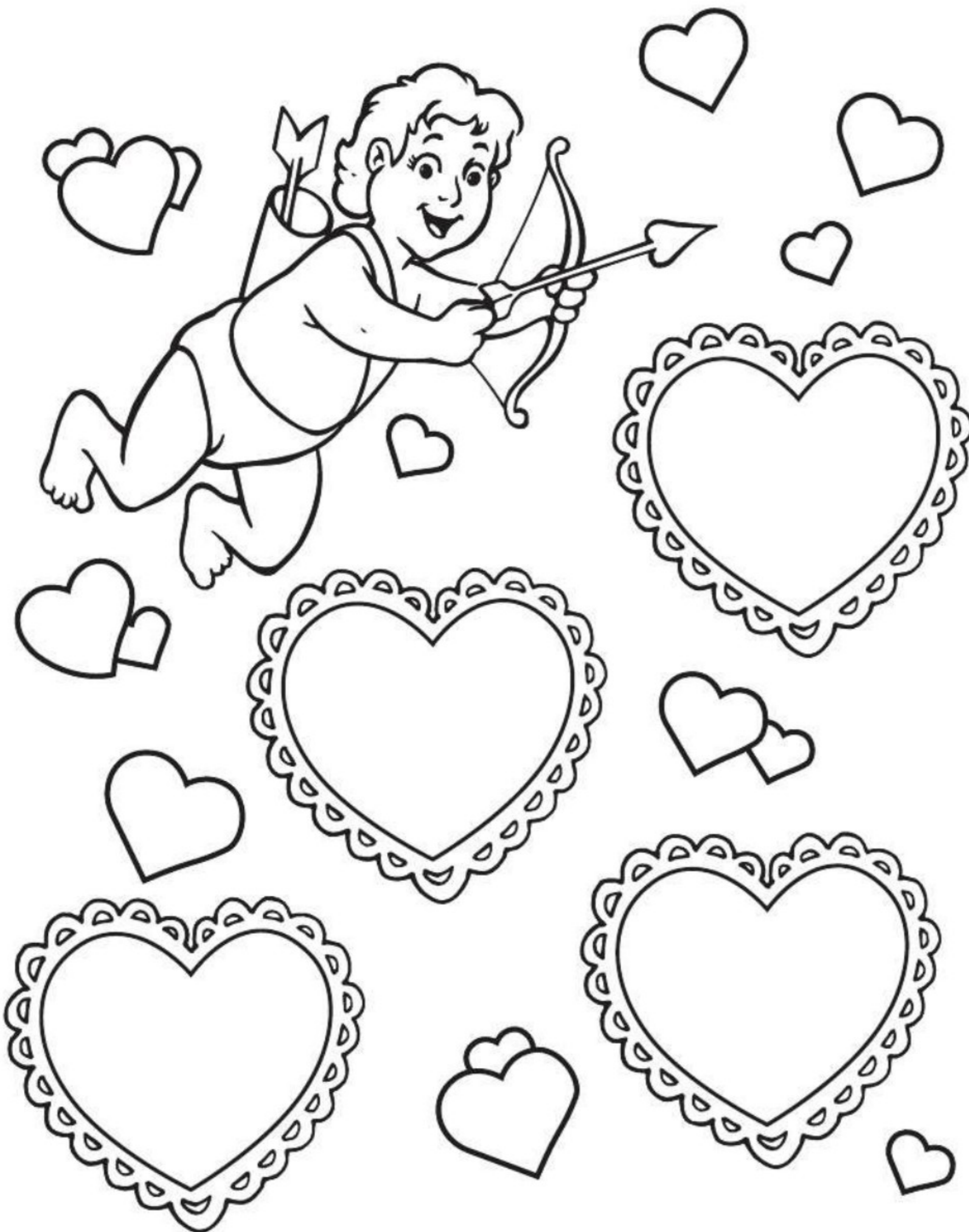



# Letter Vv

**Directions:** Circle  the **V** or **v** in these words:

**Valerie**

**violin**

**vest**

**Victor**

**valentine**

**van**

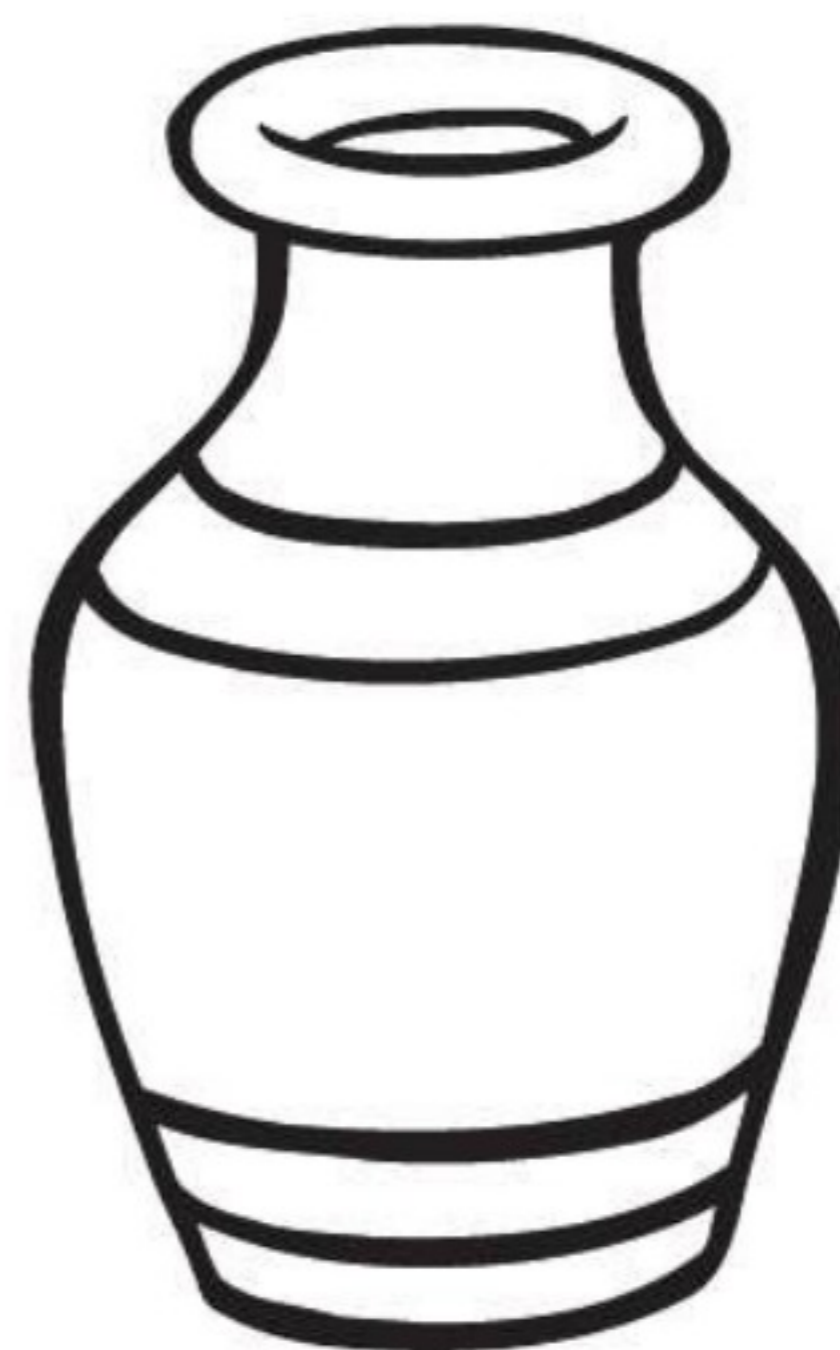
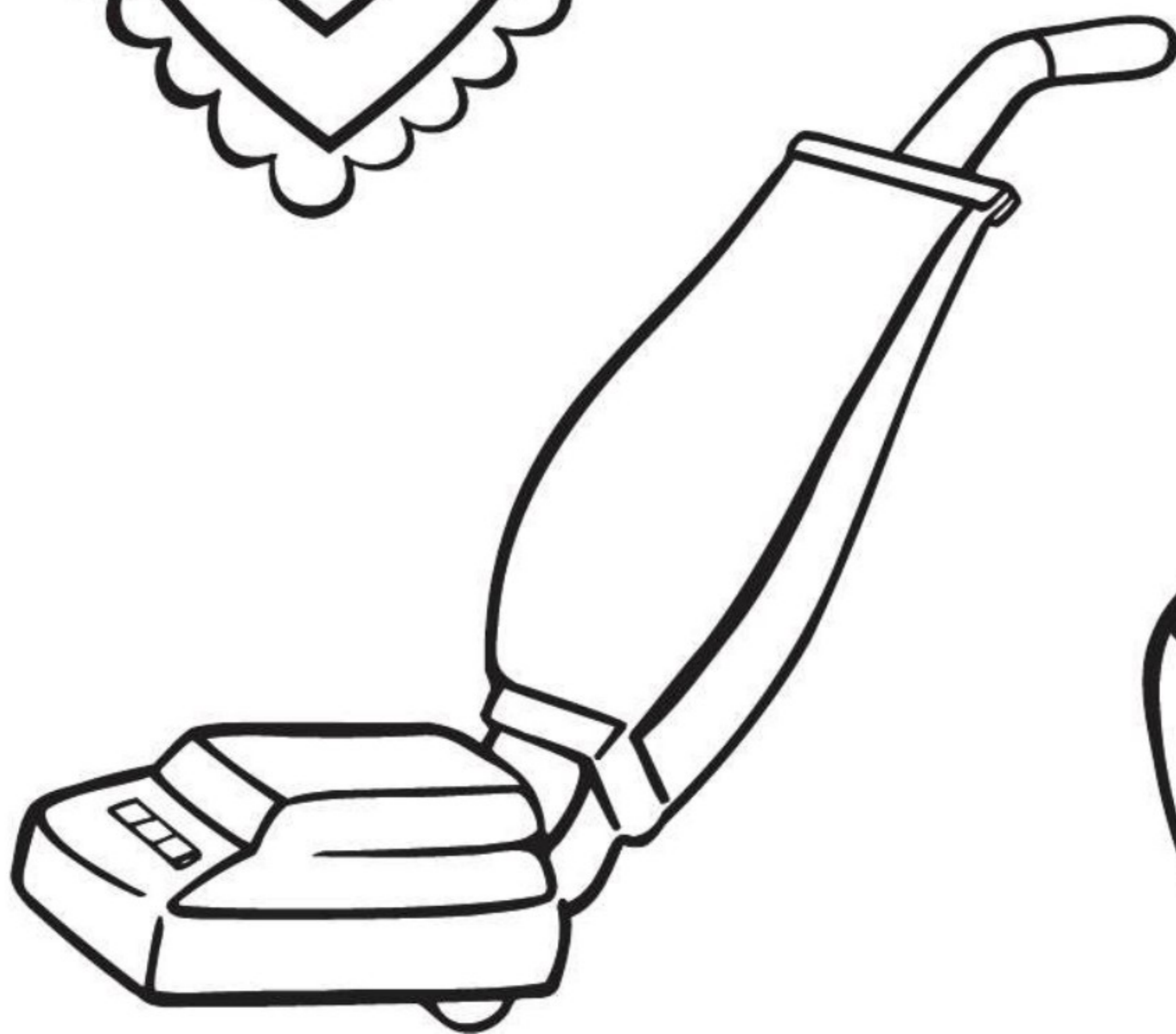
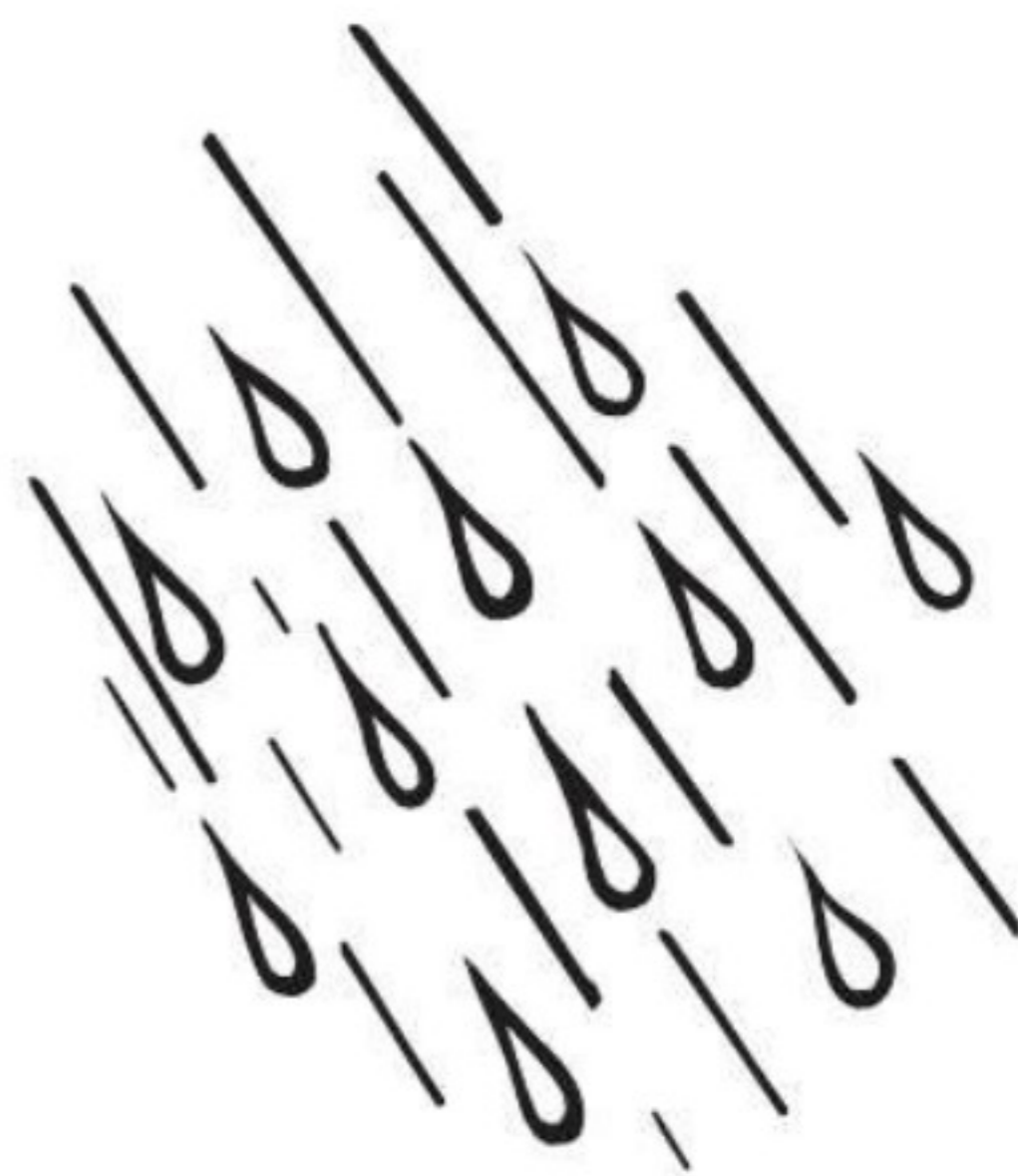
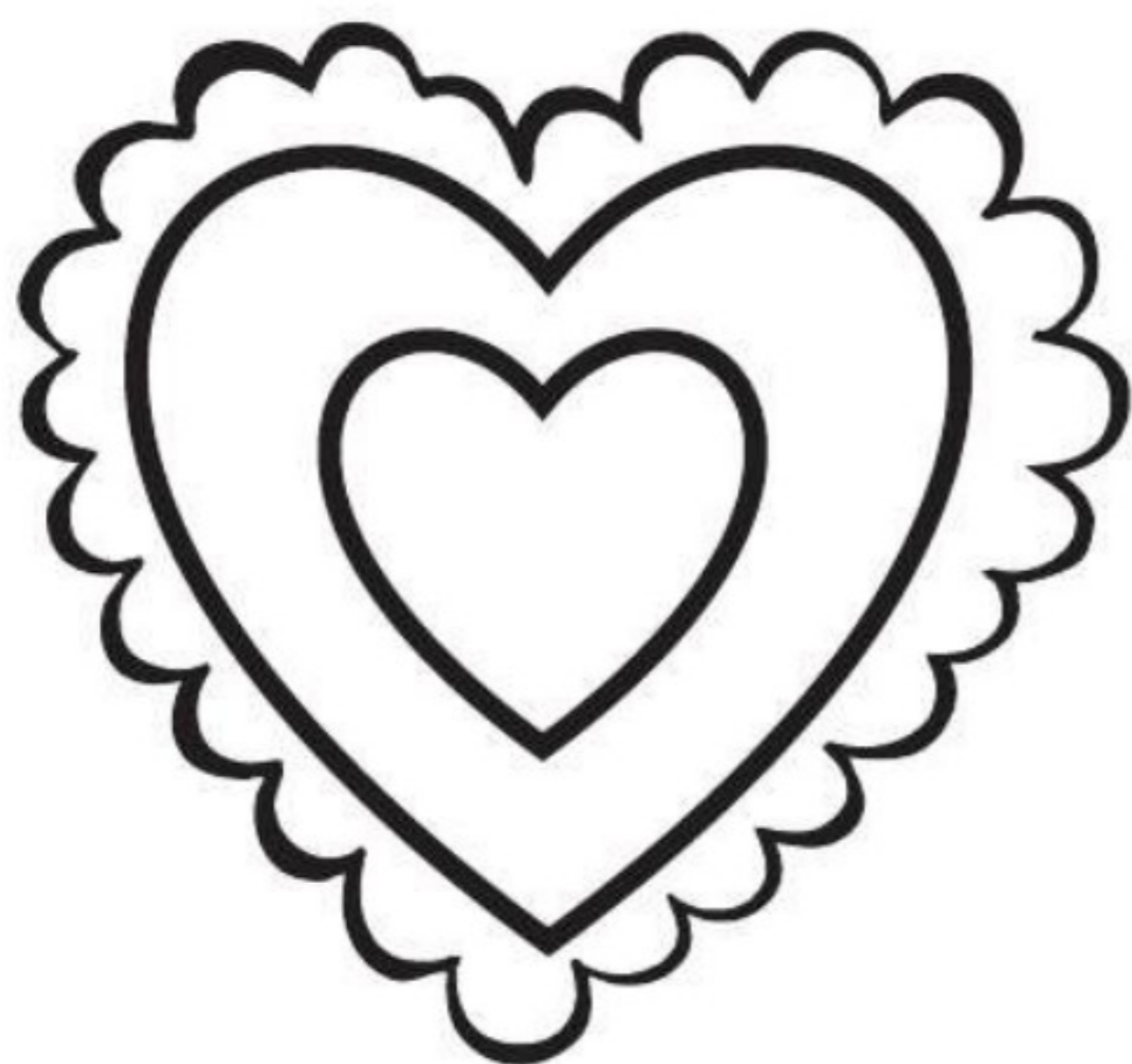

**Directions:** Color  the pictures that start with the sound of **Vv**.





# Letter Vv

Help Vern Vampire vacuum.

**Directions:** Circle  the pictures that begin with the sound of **Vv**. Color  all the pictures.

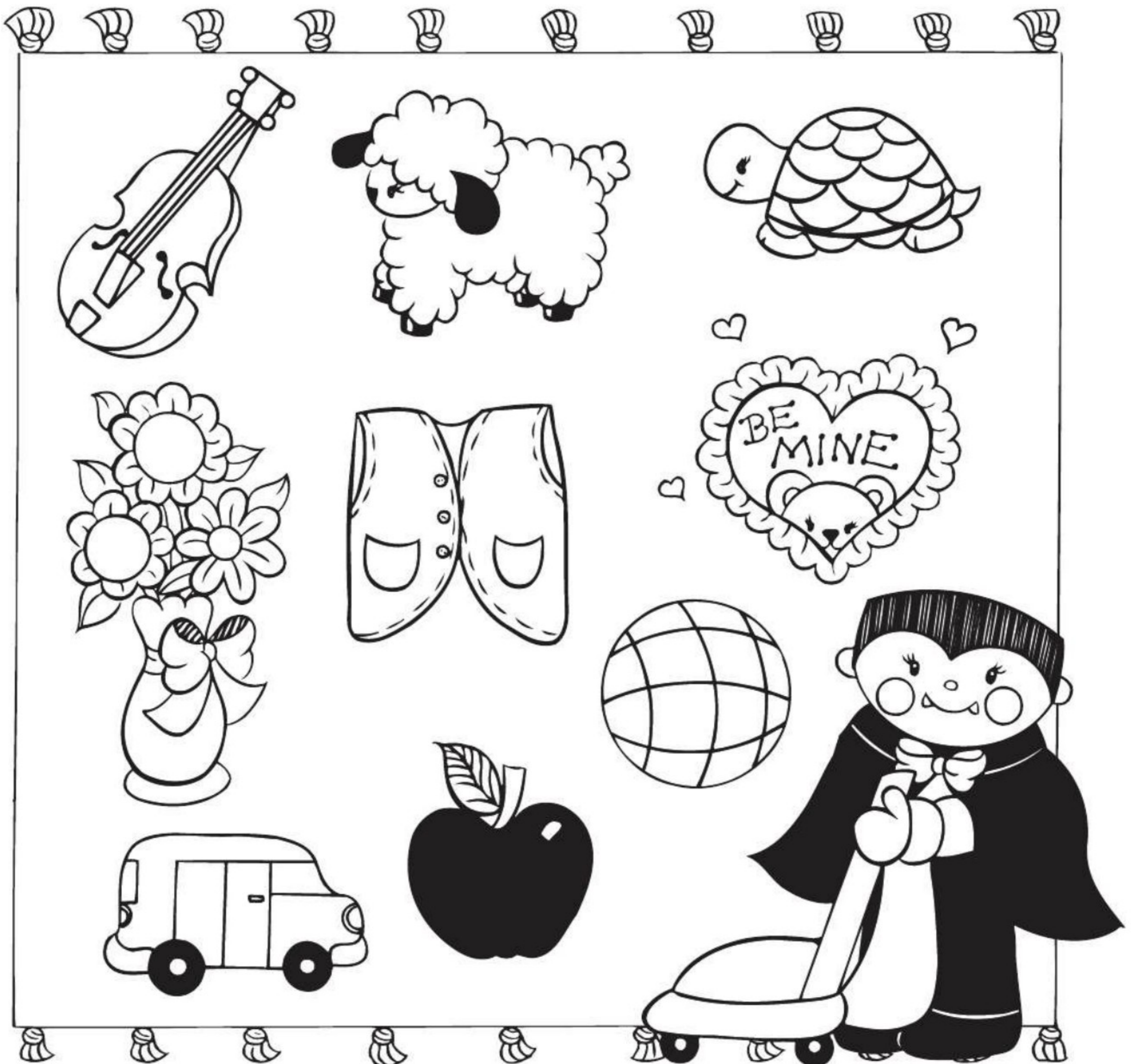



# Letter Ww



**Directions:** Trace and write  the letter Ww.

UPPERCASE

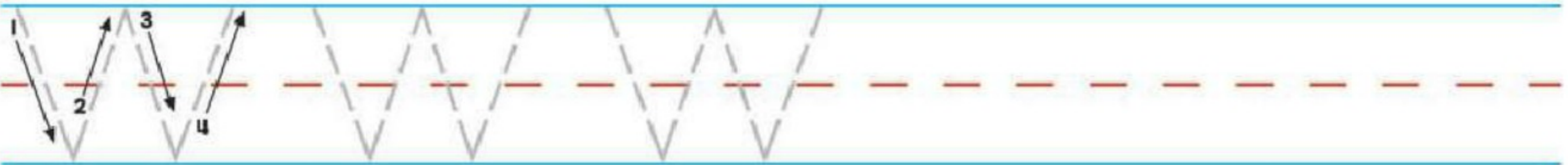

lowercase



**Directions:** These pictures begin with the letter Ww.

**Color**  the pictures.

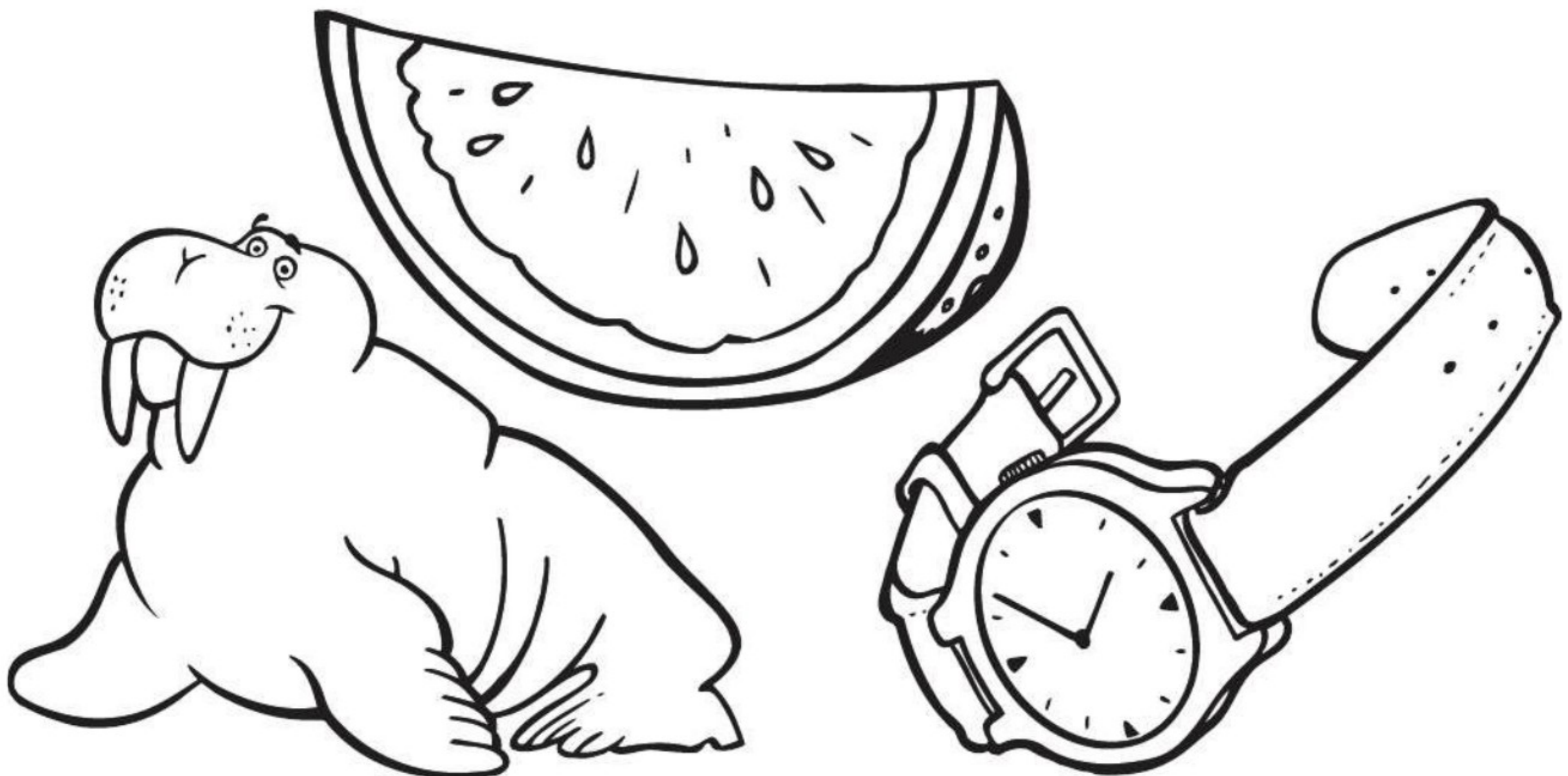



# Letter Ww

Help the spider find its home.

**Directions:** Draw  a line to follow each **W** and **w**.

**Color**  the picture.



# Letter Ww

**Directions:** Circle  the **W** or **w** in these words:

window

Walter

walk

win

white

Wendy

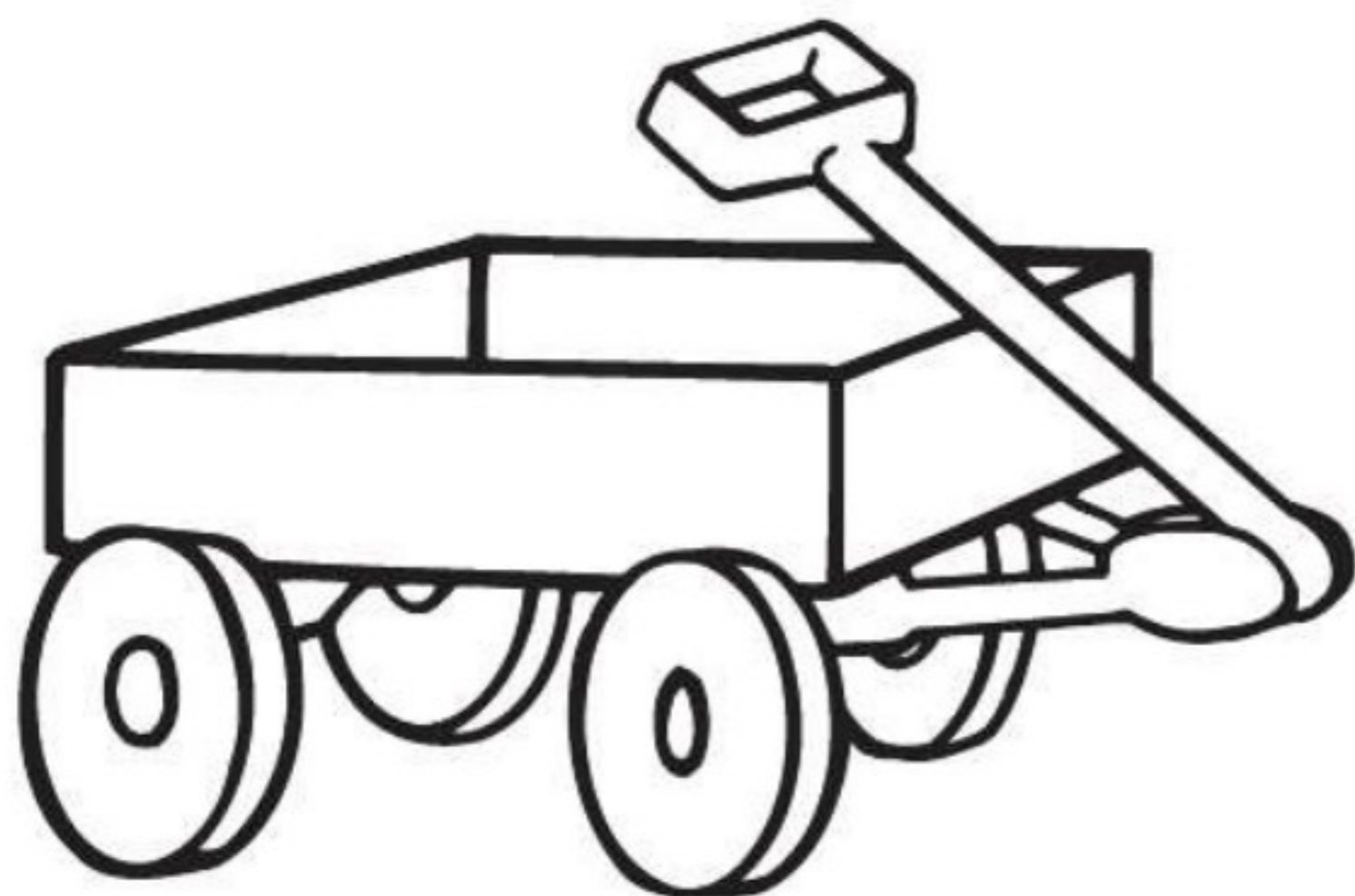
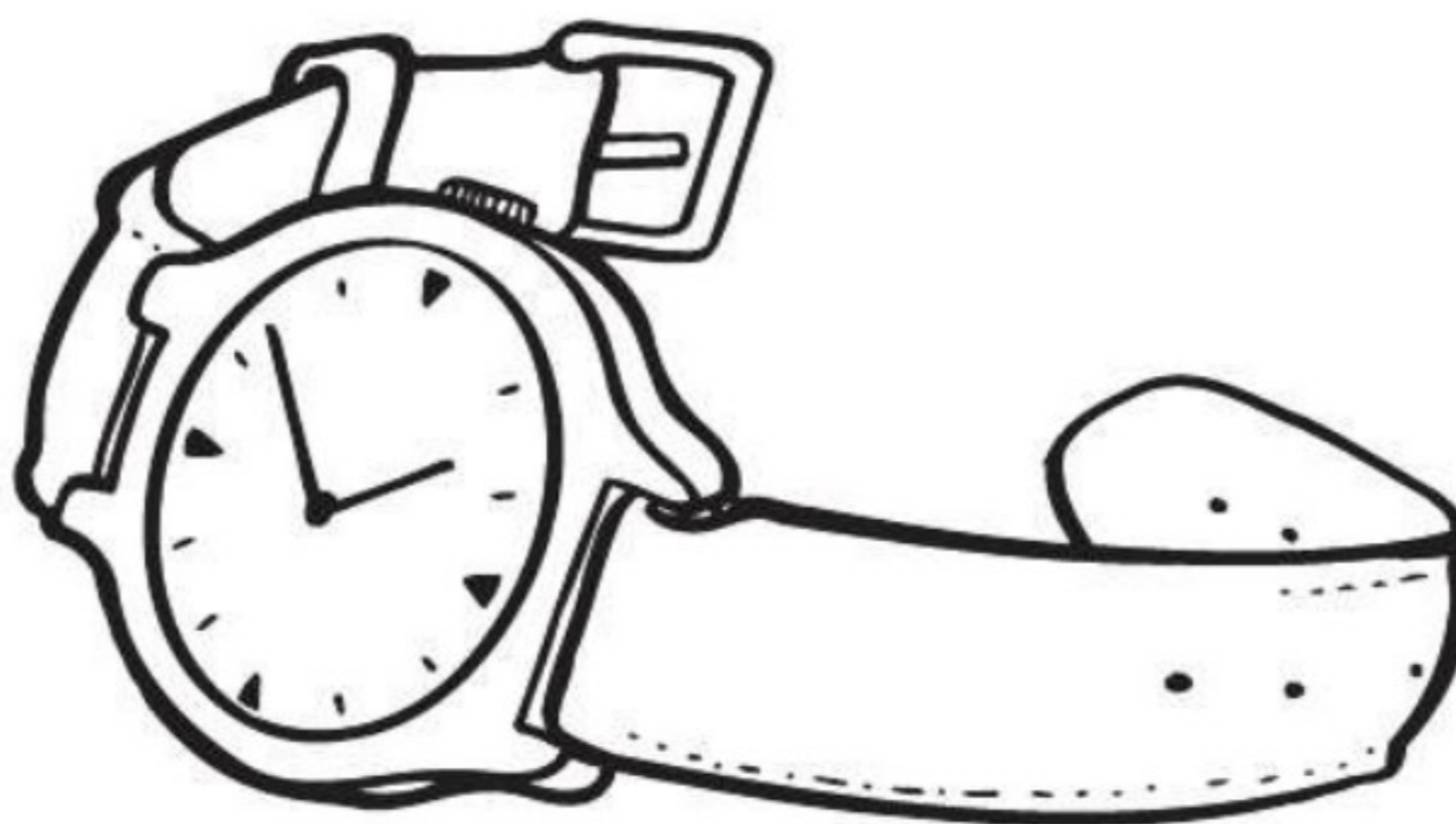
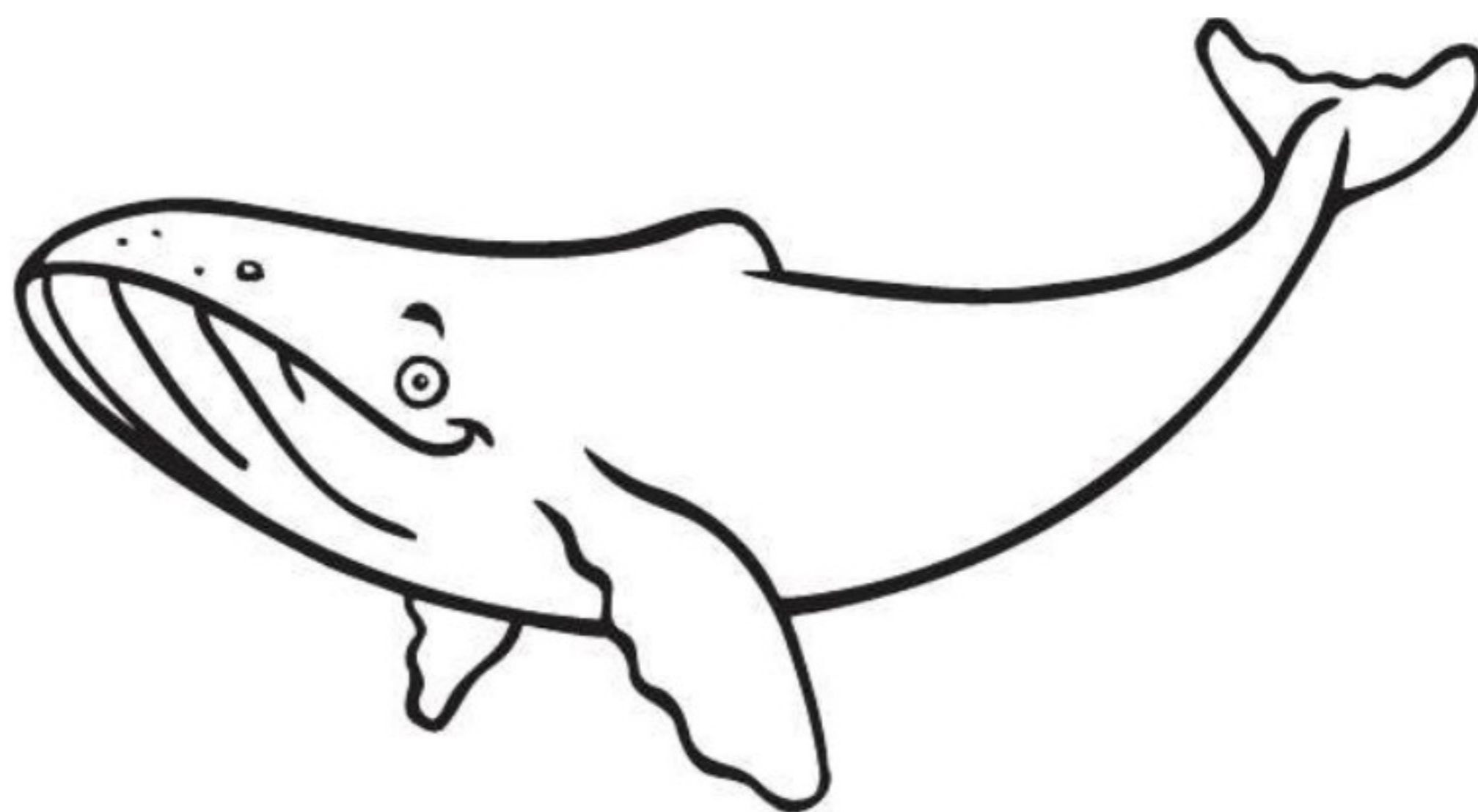

**Directions:** Color  the pictures that start with the sound of **Ww**.





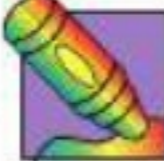

# Letter Ww

**Directions:** Color  each of the pictures that begin with the sound of **Ww**. Then, **draw**  a line from each colored picture to a watch face.

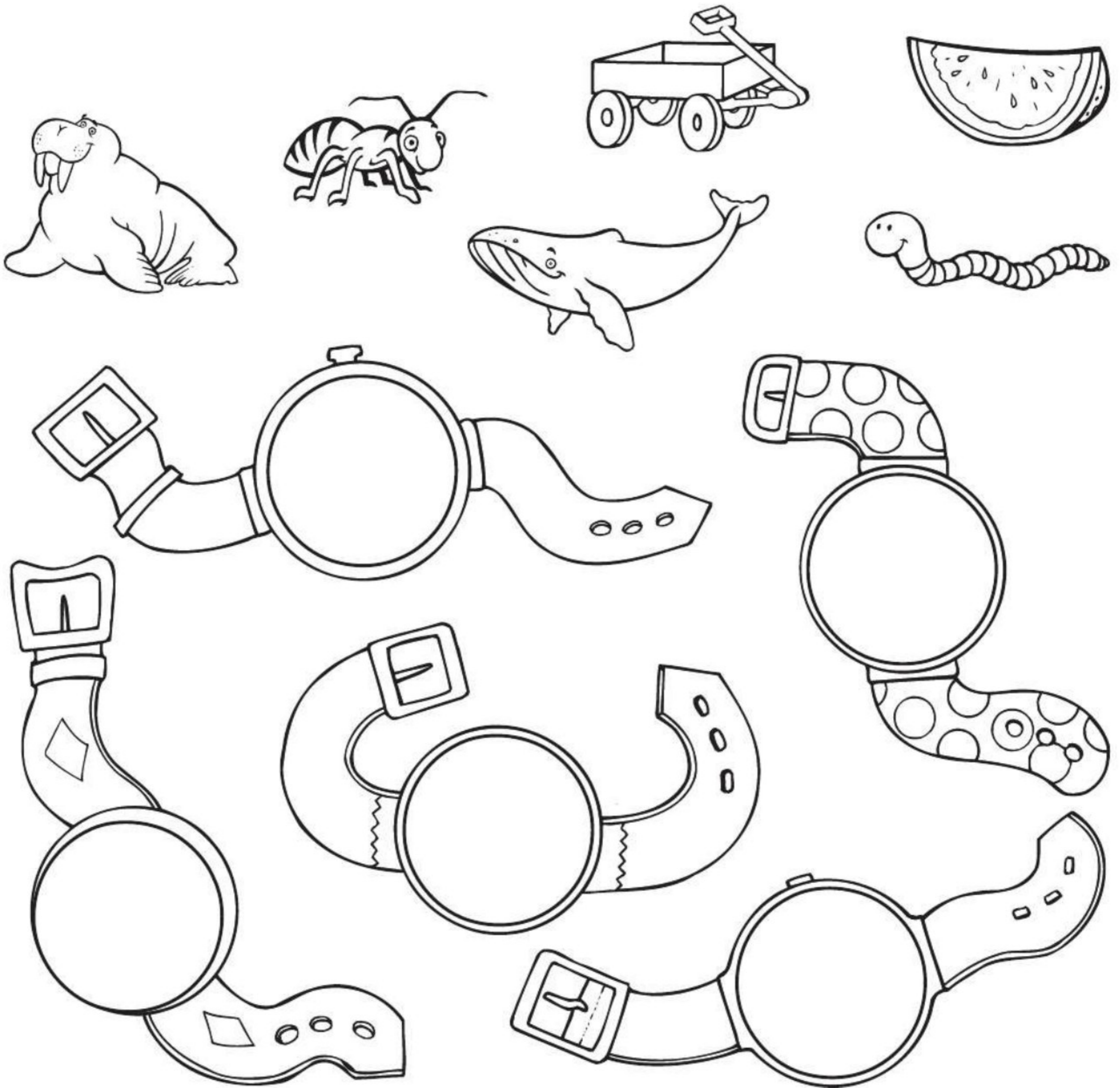



# Letter Xx

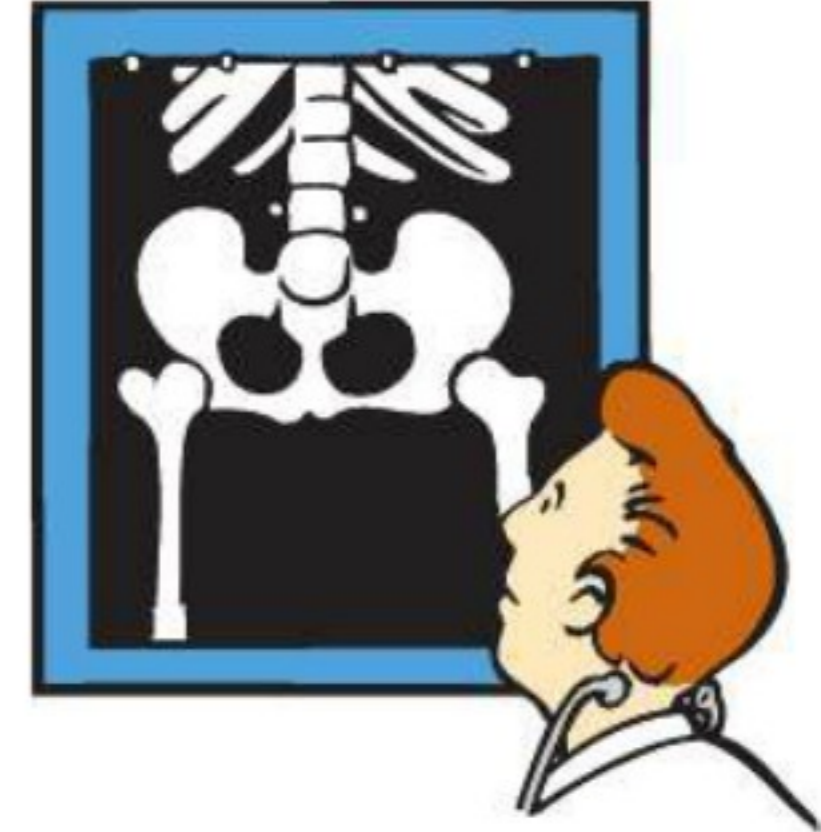

**Directions:** Trace and write  the letter **Xx**.

UPPERCASE



lowercase



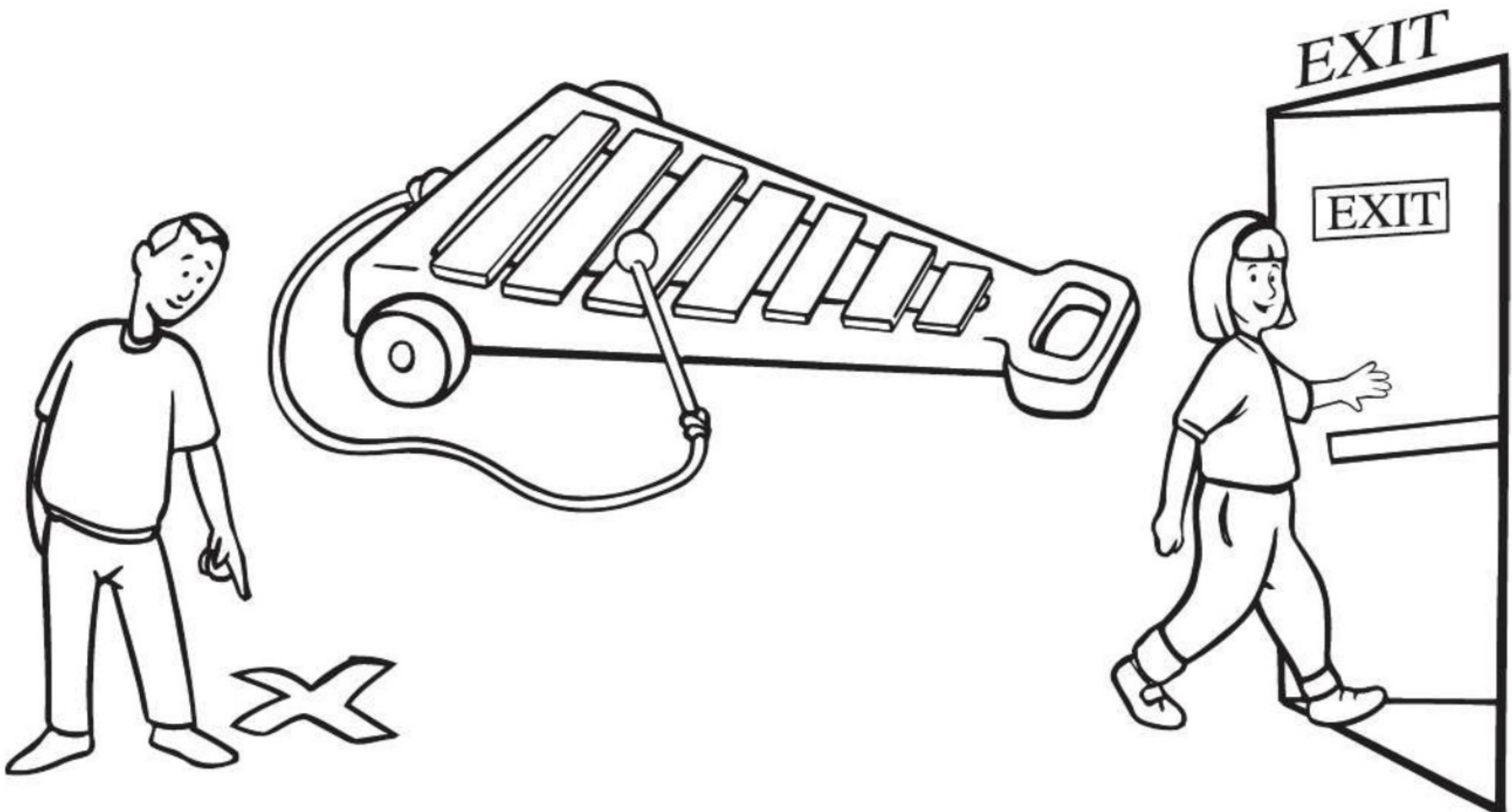

**Directions:** These pictures have the letter **Xx**.

**Color**  the pictures.





## Letter Xx

**Directions:** Color  each **UPPERCASE X** red. Color each **lowercase x** blue. For each **UPPERCASE** letter, write  its matching **lowercase** letter next to it. For each **lowercase** letter, write its matching **UPPERCASE** letter next to it.

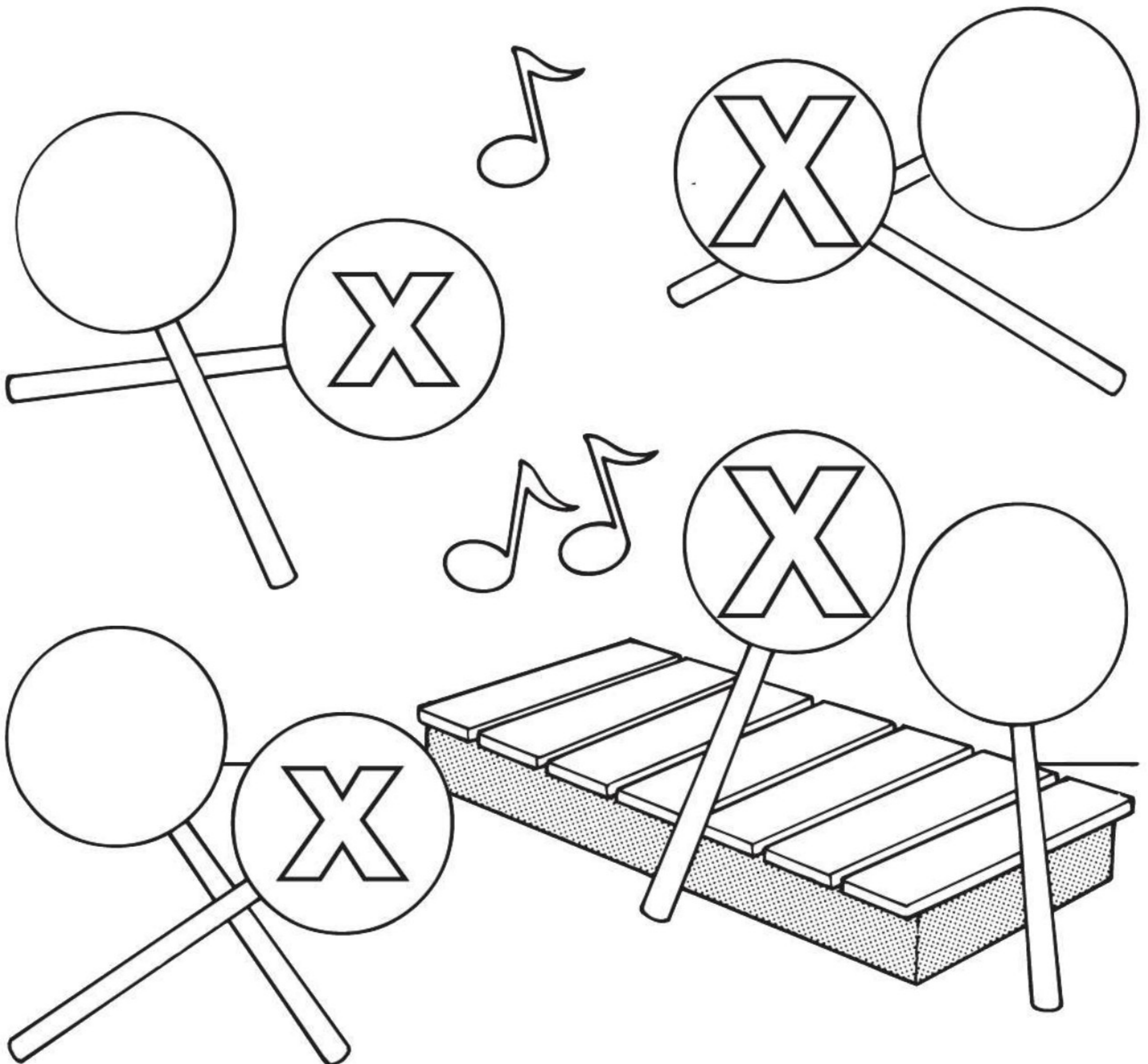



# Letter Xx

**Directions:** Circle  the **X** or **x** in these words:

**Xavier**

**X ray**

**exit**

**Rex**

**xylophone**

**tax**

**Directions:** Color  the pictures that have the sound of **Xx**.

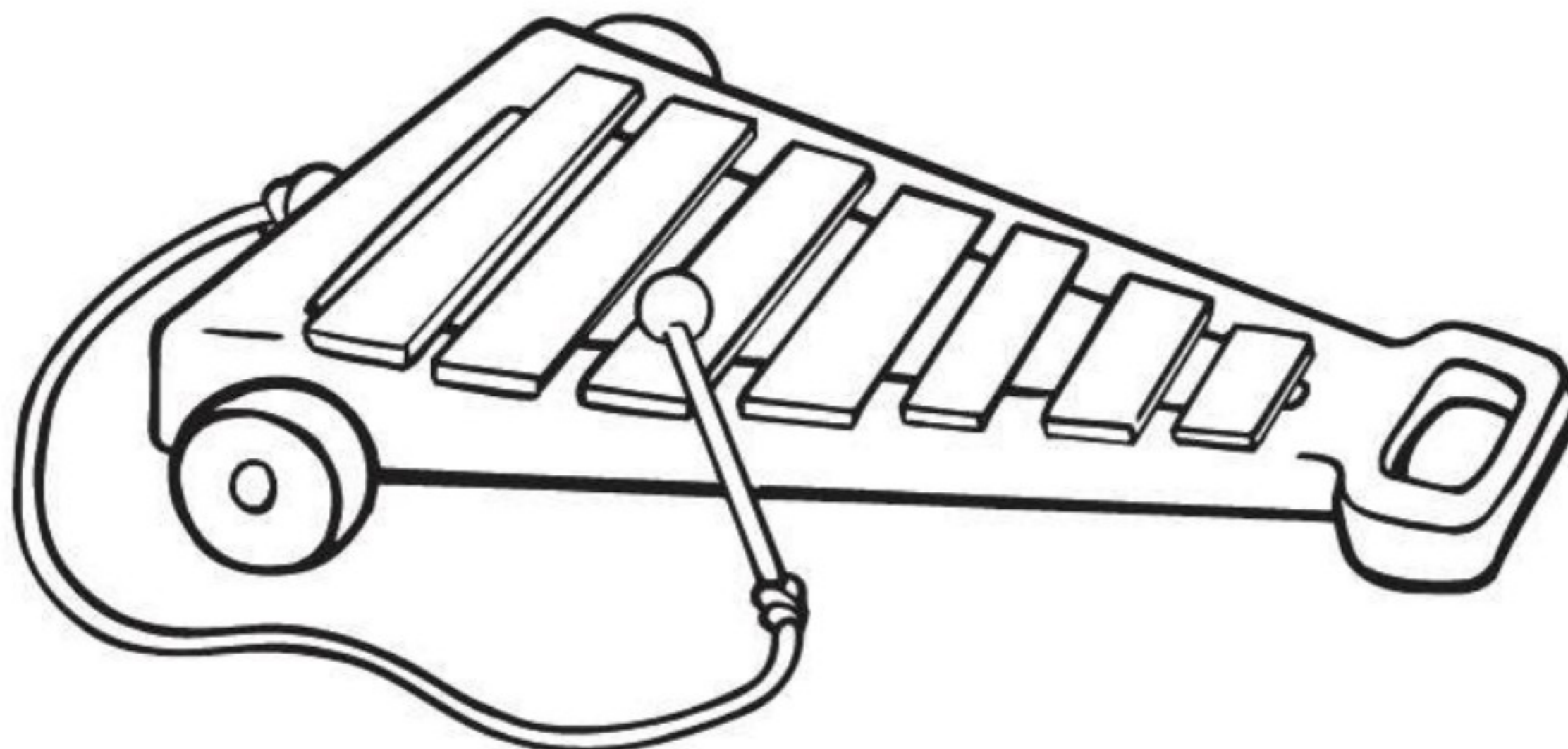
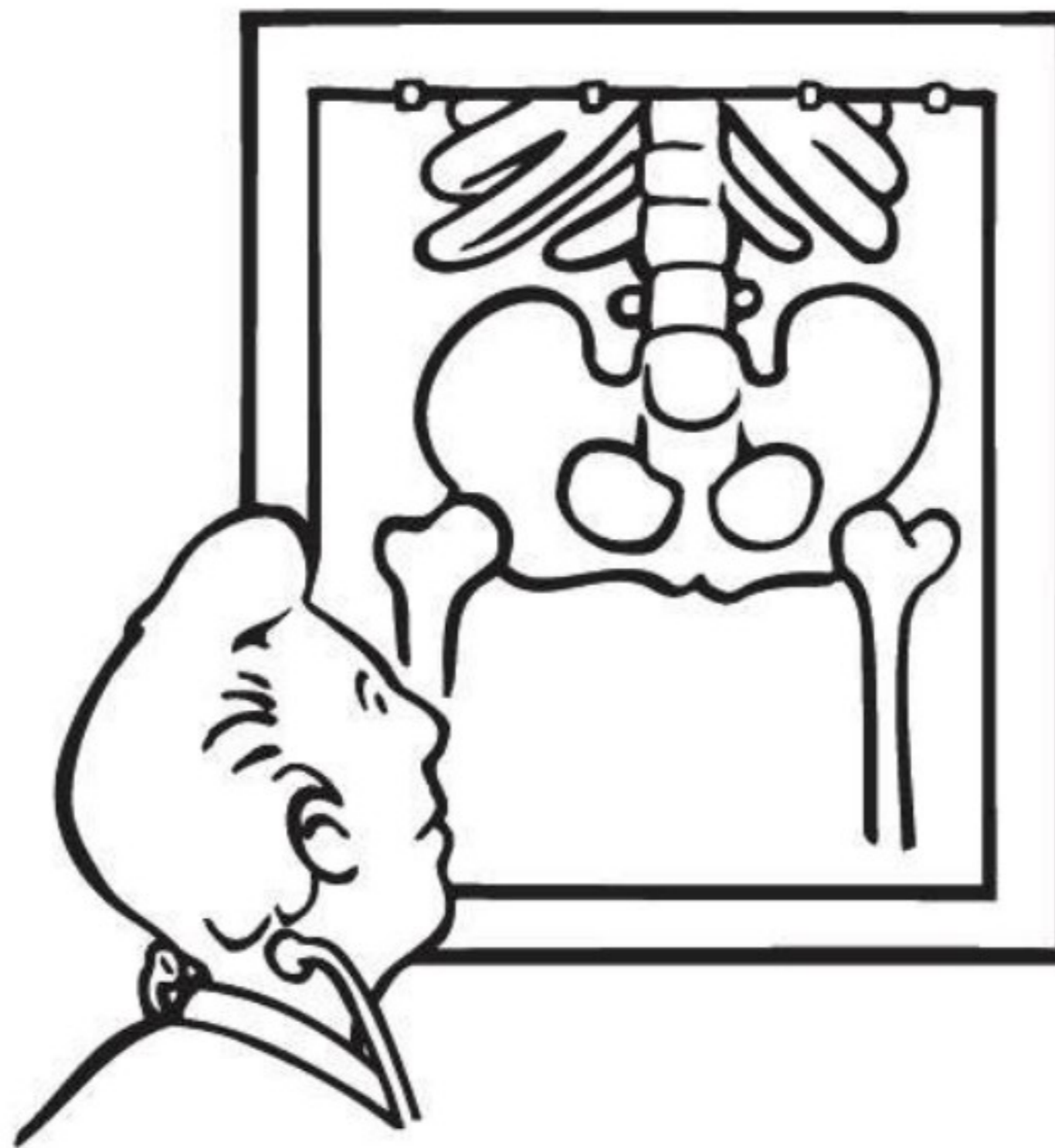



# Letter Xx

These words start with **X** or **x**.

**Directions:** Write  a lowercase **x** on each line.

**Color**  the pictures.

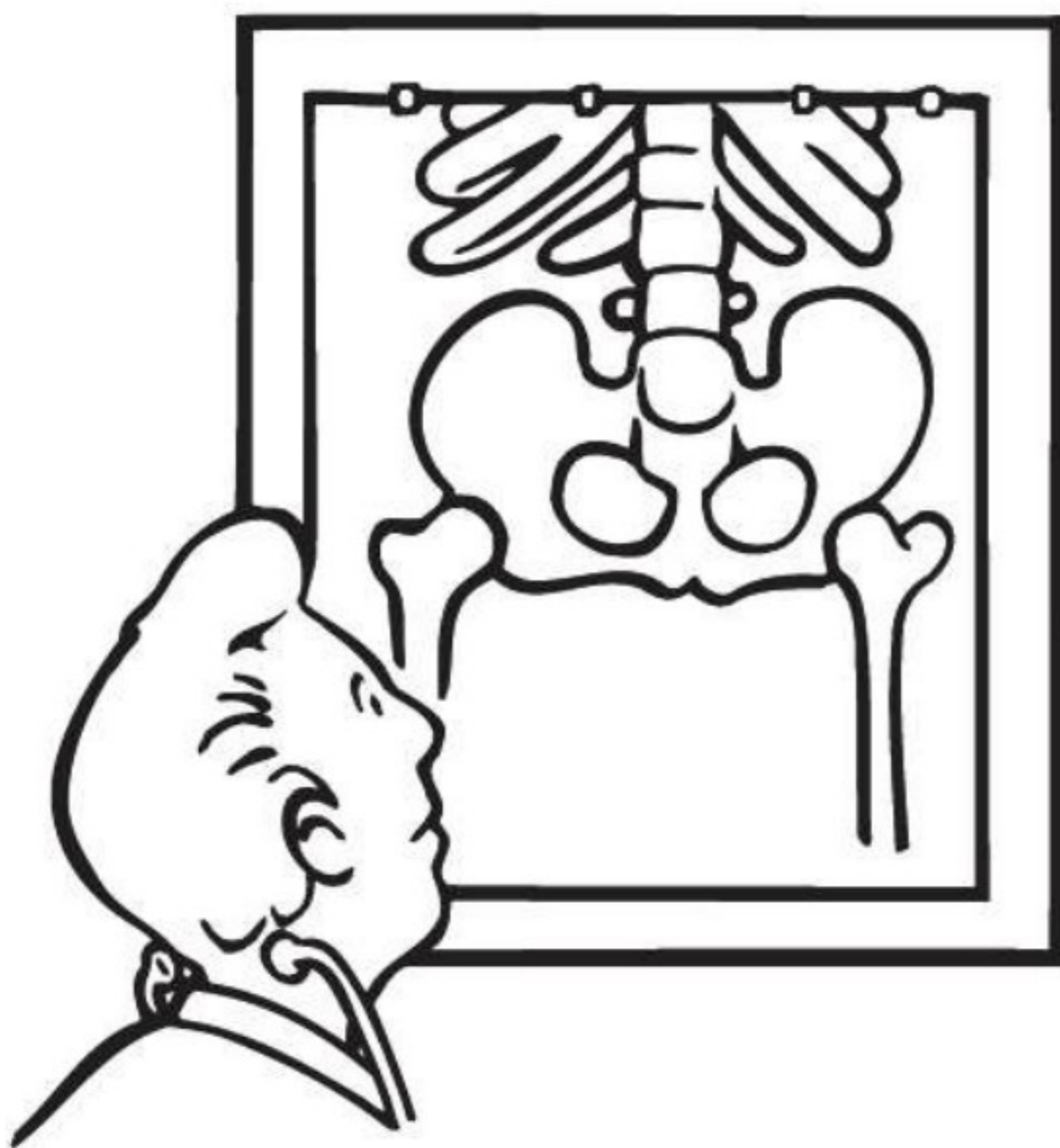

**X** is for  ray.

**X** is in E  it.



**X** is for  ylophone.

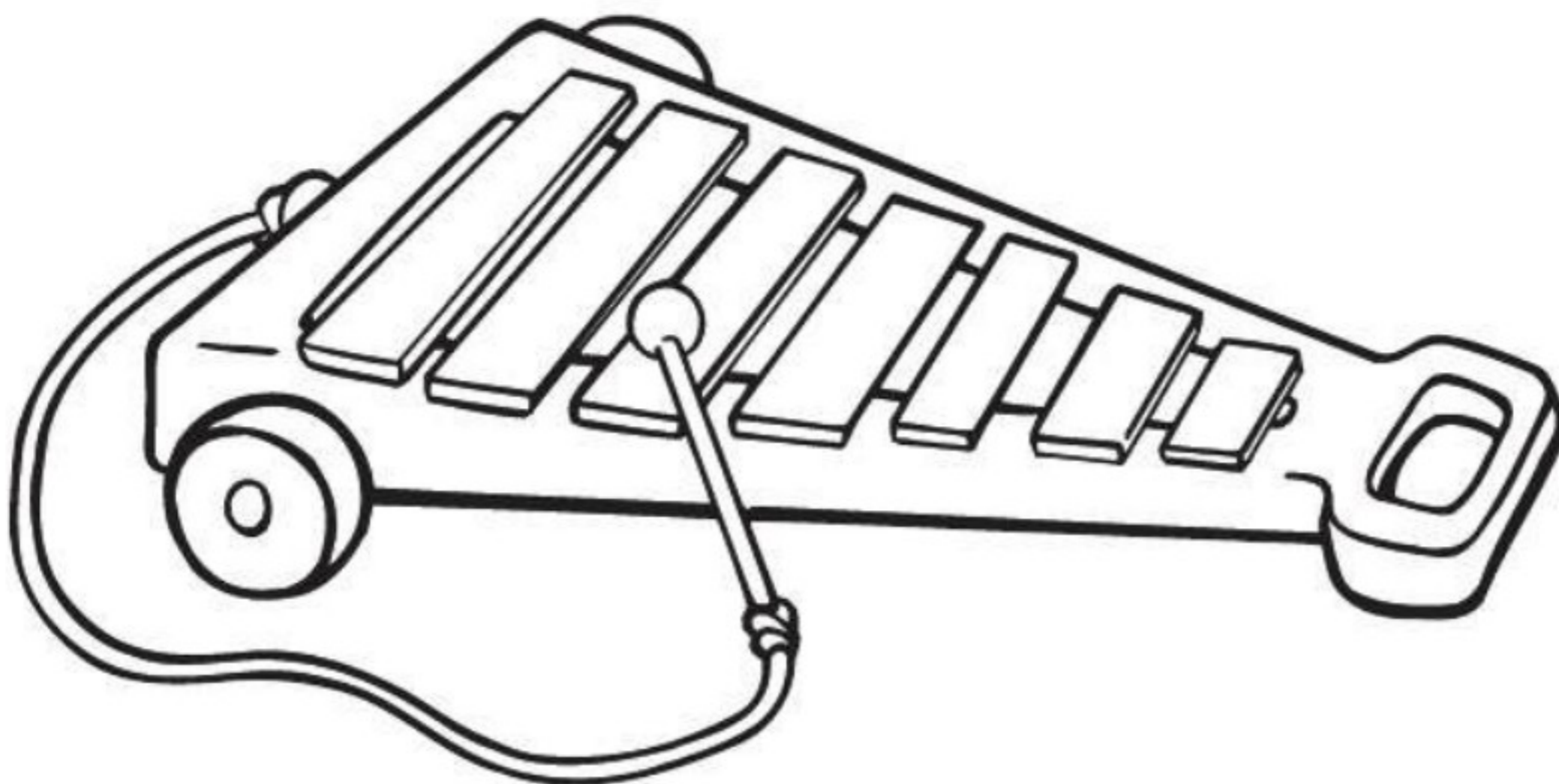



# Letter Yy

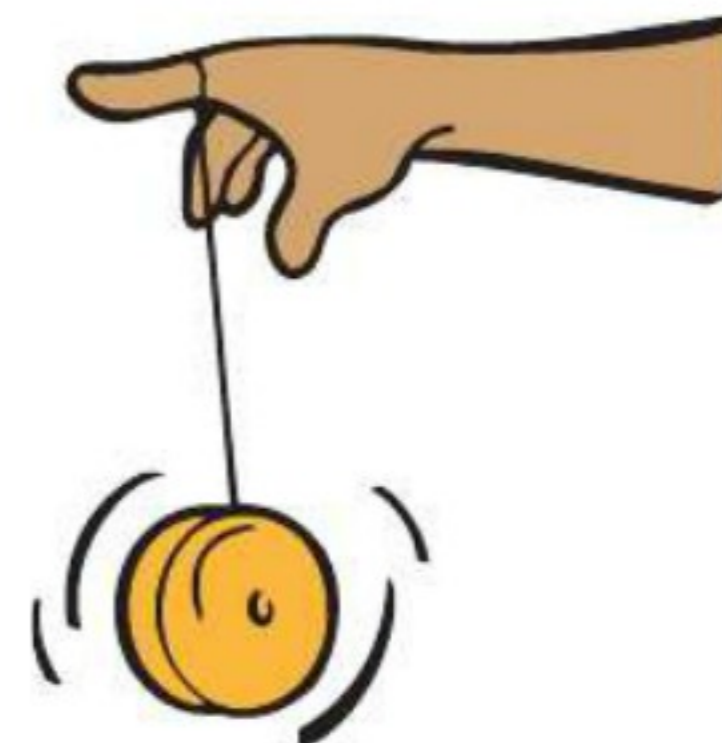

**Directions:** Trace and write  the letter Yy.

UPPERCASE



lowercase

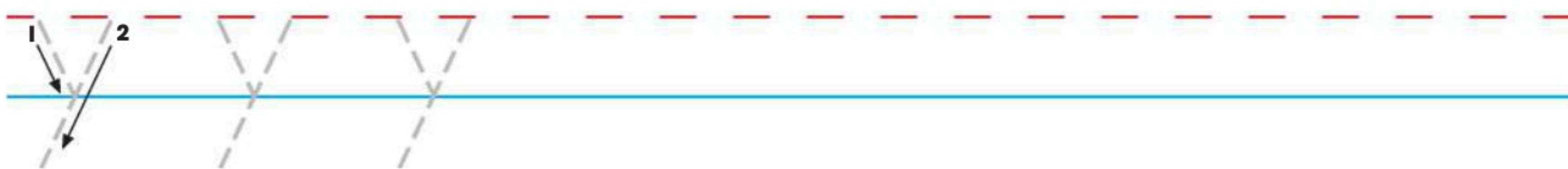

**Directions:** These pictures begin with the letter Yy.

**Color**  the pictures.

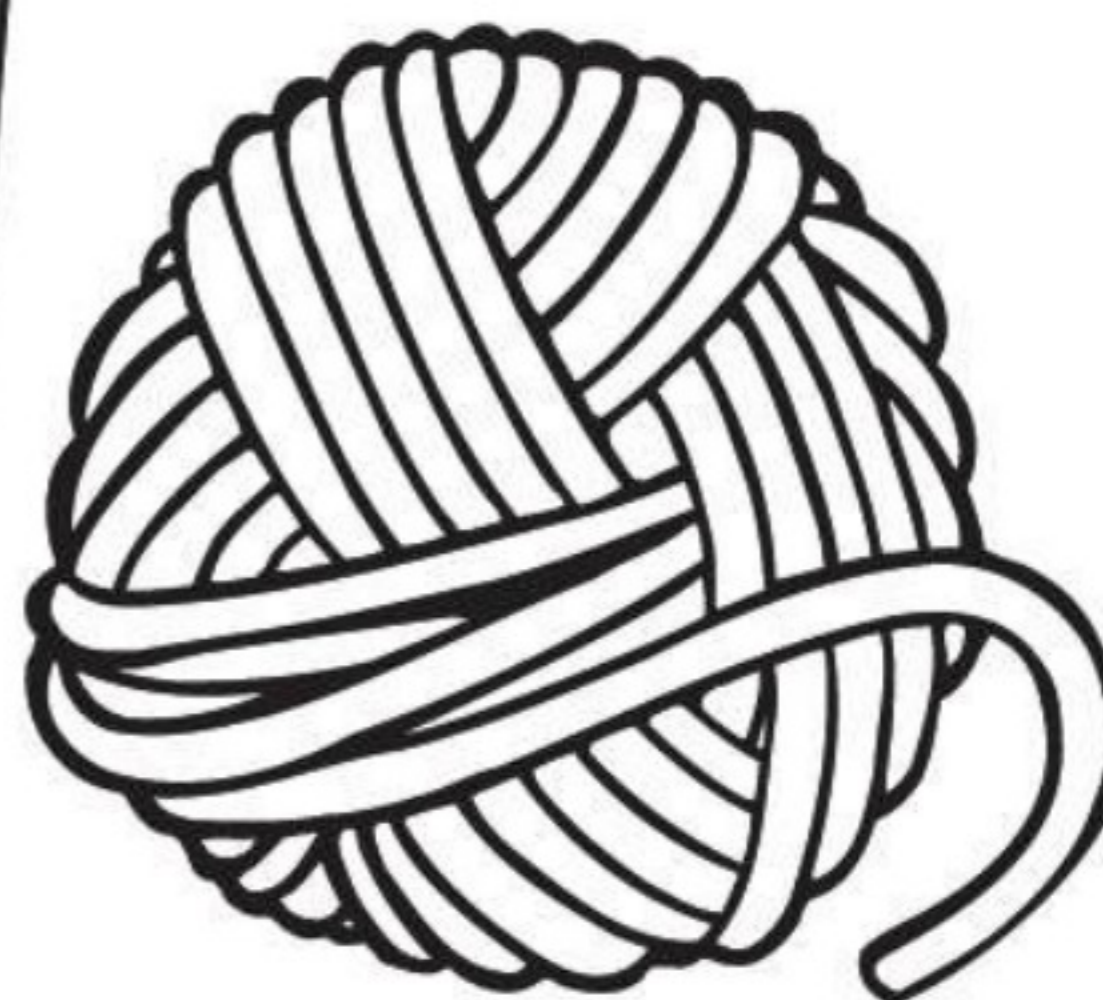
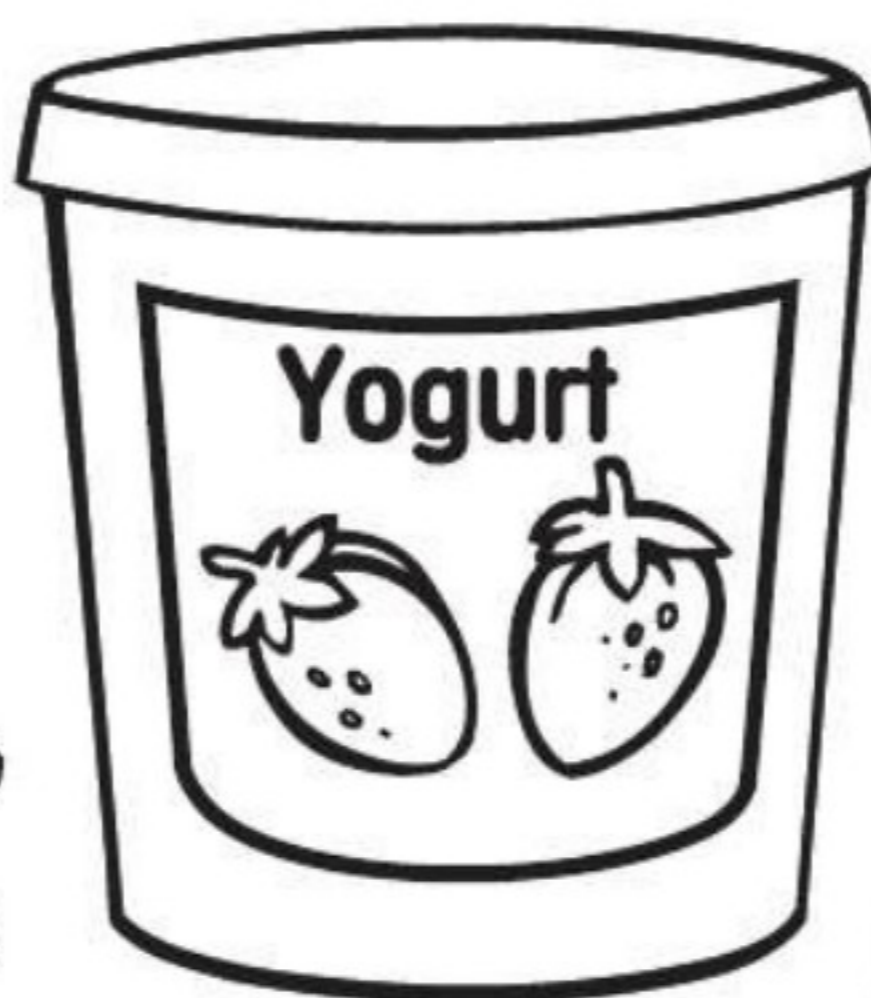

Name \_\_\_\_\_



# Letter Yy

Find each **Y** and **y** hidden in the yard.

**Directions:** Color  each **Y** red and each **y** yellow.

Color  the rest of the yard and make it fun!





# Letter Yy

**Directions:** Circle  the Y or y in these words:

yarn

yo-yo

yard

Yuri

Yvonne

yes

**Directions:** Color  the pictures that start with the sound of Yy.

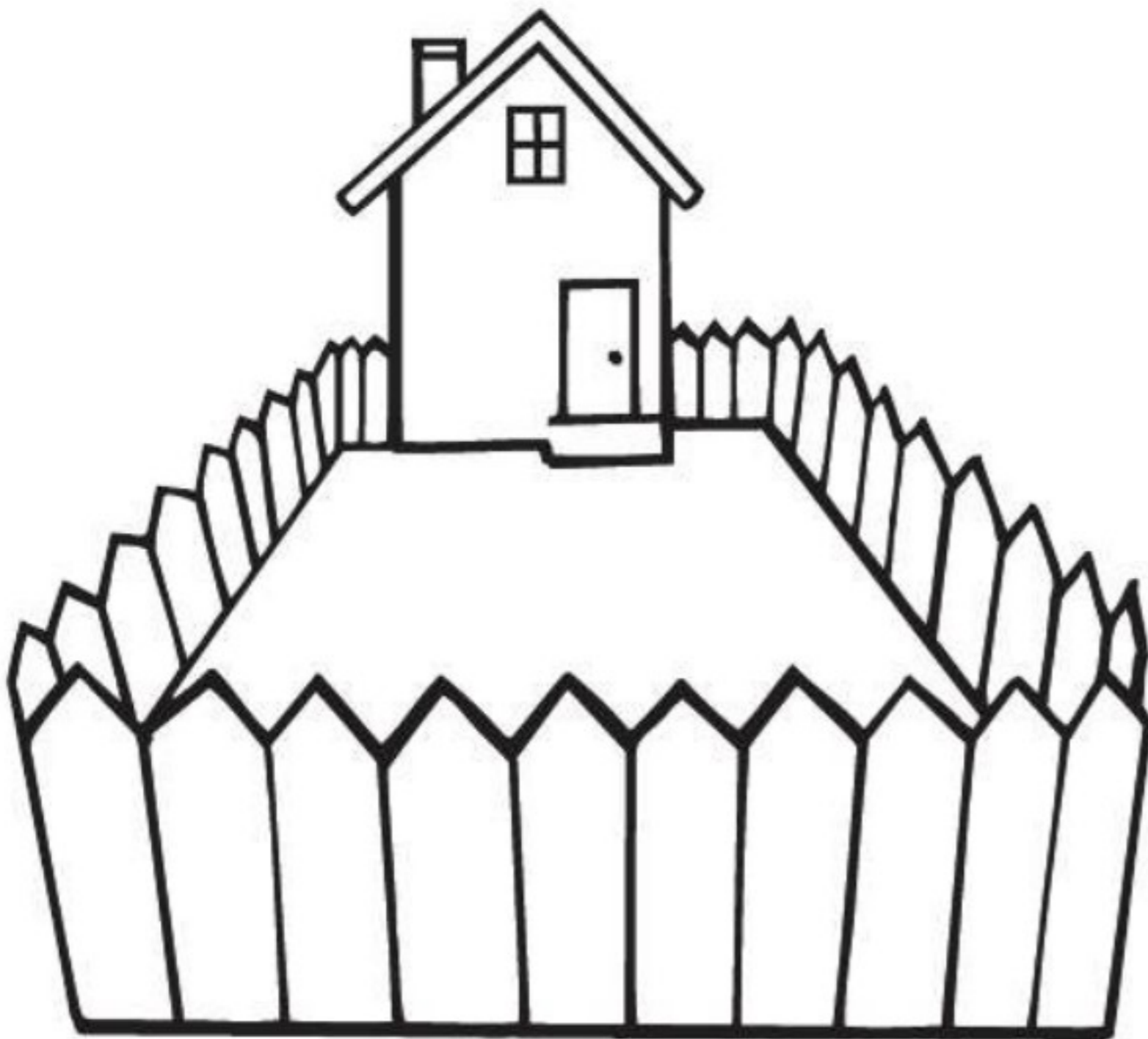
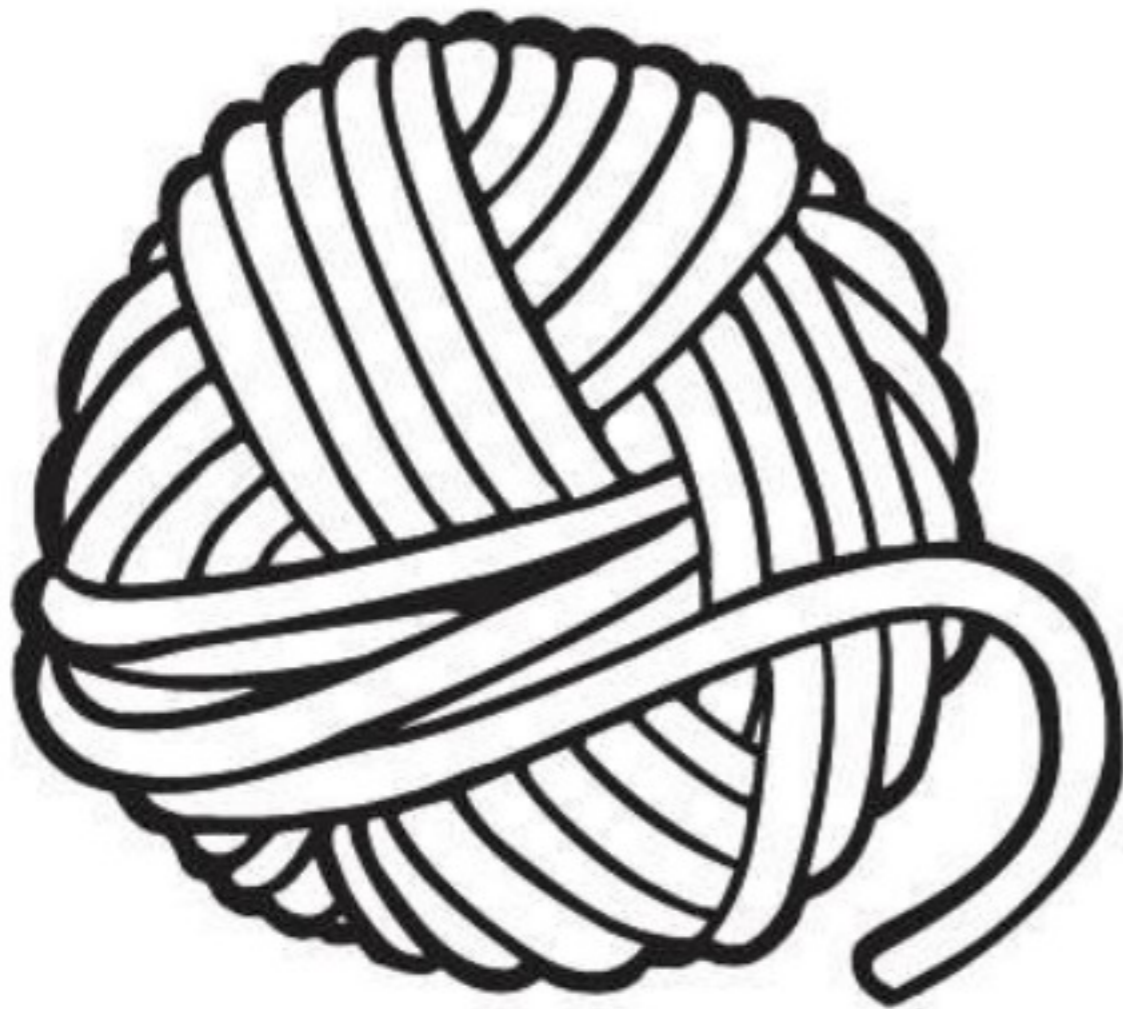





# Letter Yy

Make this yo-yo spin.

**Directions:** Color  only the pictures that begin with the sound of **Yy**.

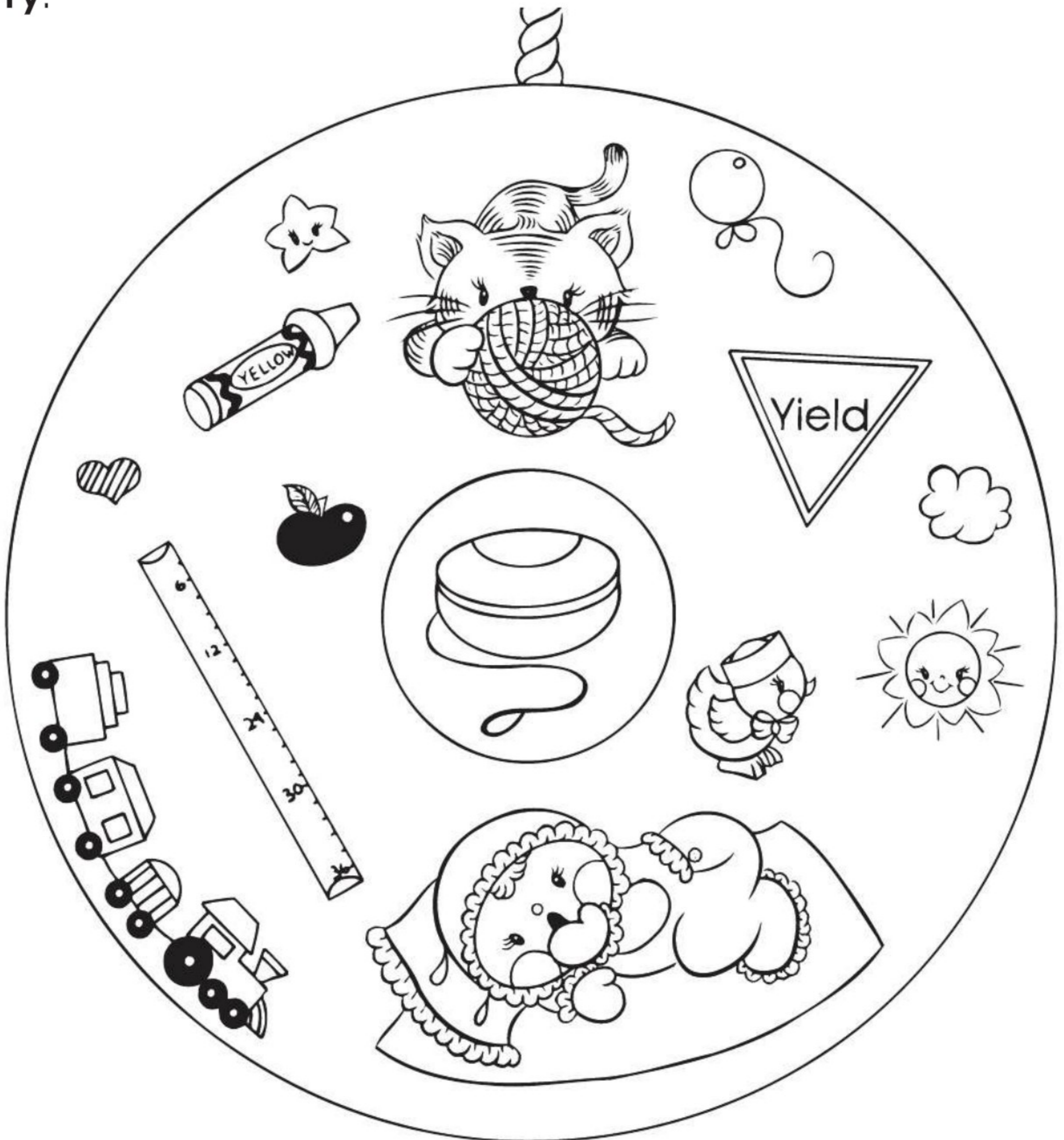



# Letter Zz



**Directions:** Trace and write  the letter **Zz**.

UPPERCASE



lowercase



**Directions:** These pictures begin with the letter **Zz**.

**Color**  the pictures.

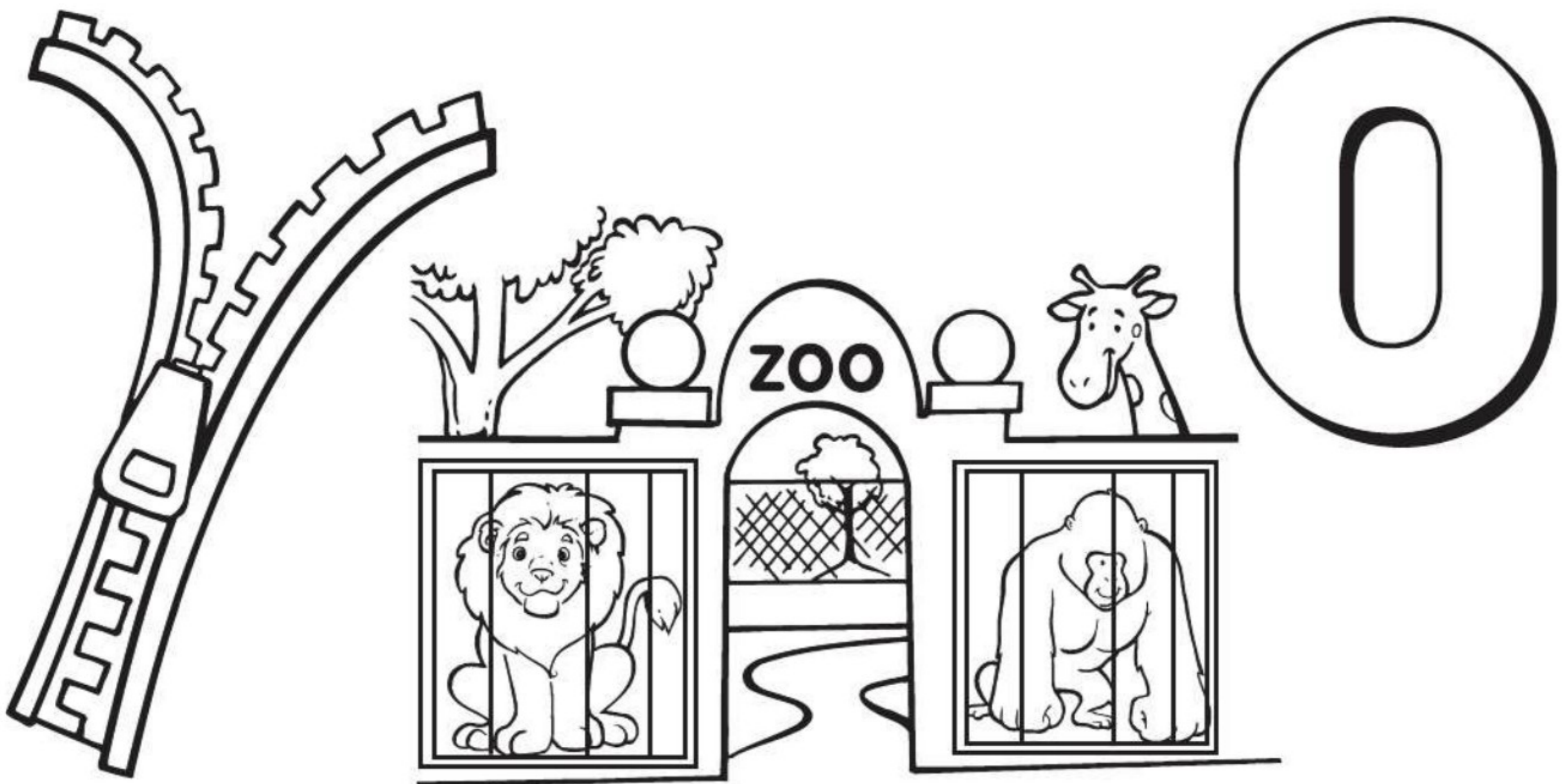



# Letter Zz

Take a trip through the zoo.

**Directions:** Color  only the pictures that begin with the sound of Zz.

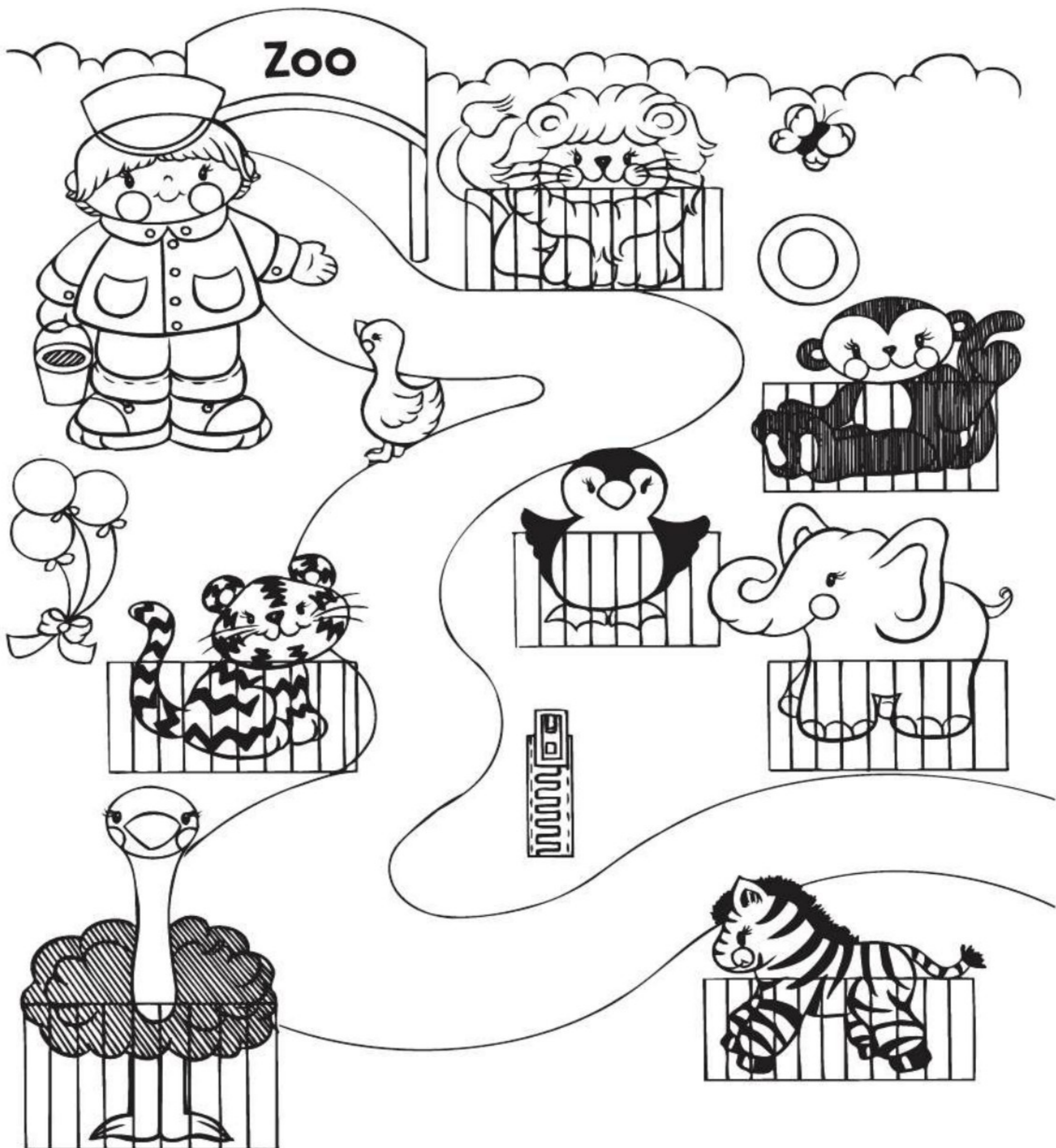



# Letter Zz

**Directions:** Circle  the **Z** or **z** in these words:

zipper

zebra

zig-zag

Zelda

zero

zoo

**Directions:** Color  the pictures that start with the sound of **Zz**.

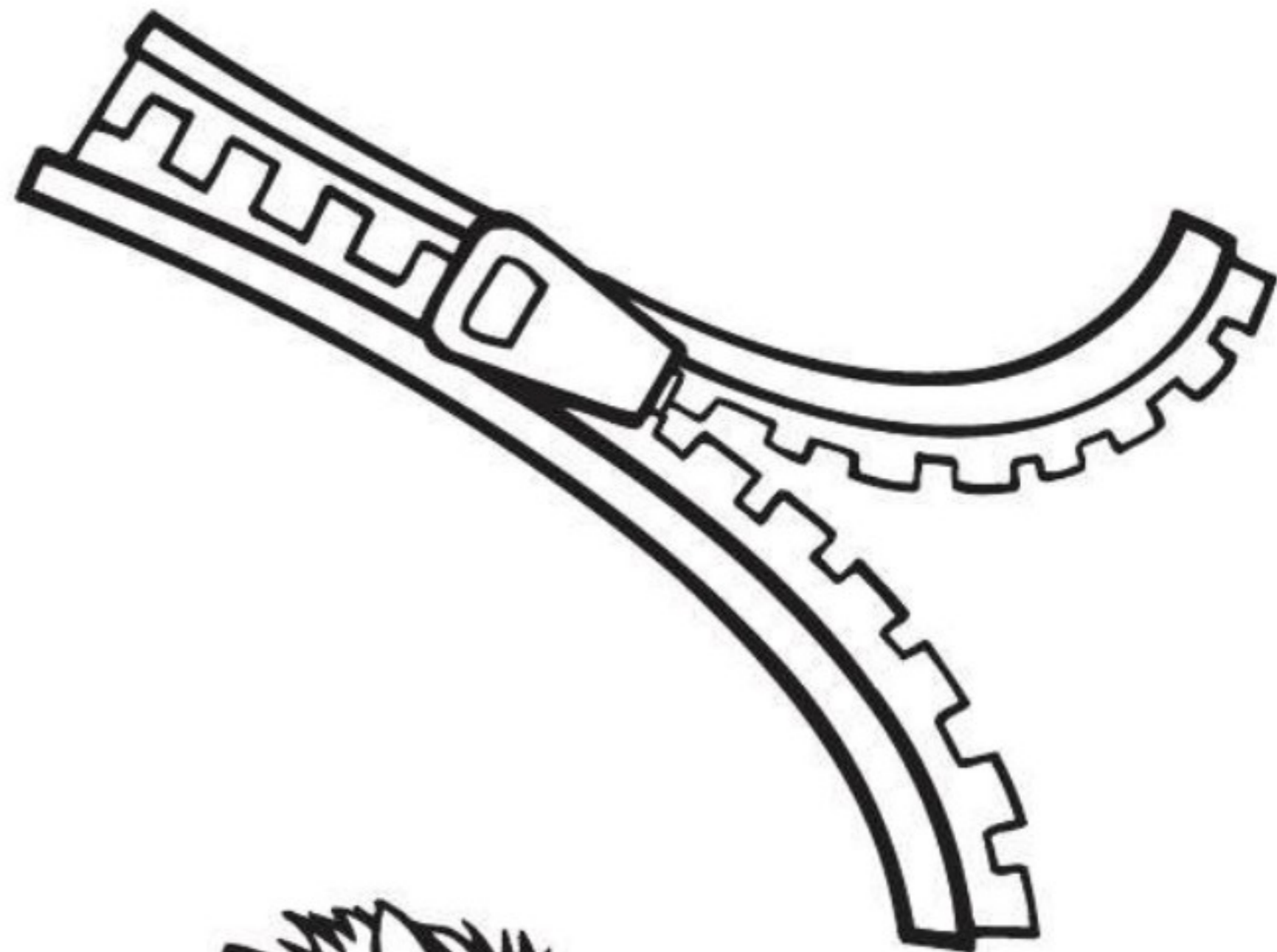
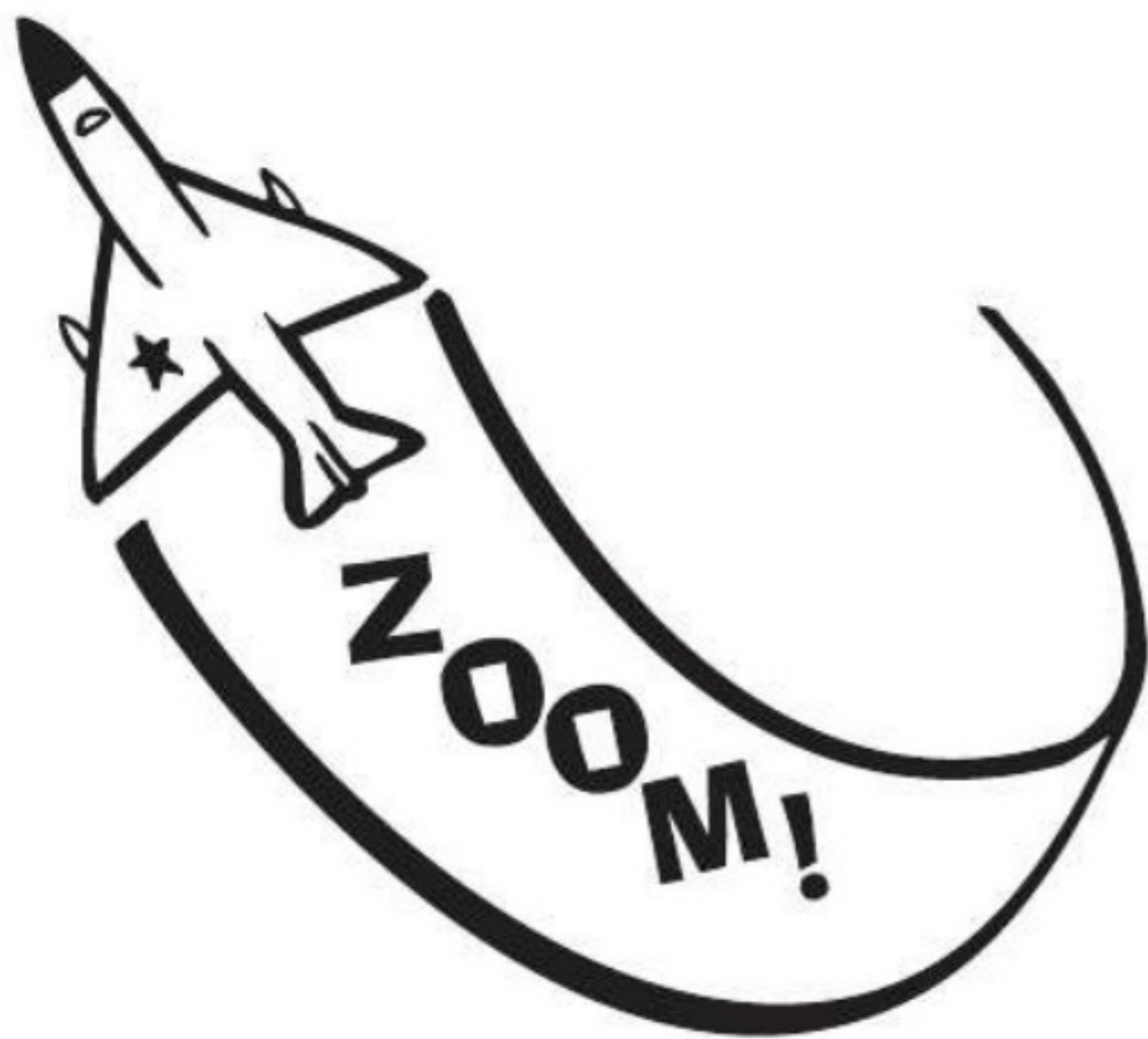



# Letter Zz

These words start with **Z** or **z**.

**Directions:** Write  a lowercase **z** on each line.

**Color**  the pictures.

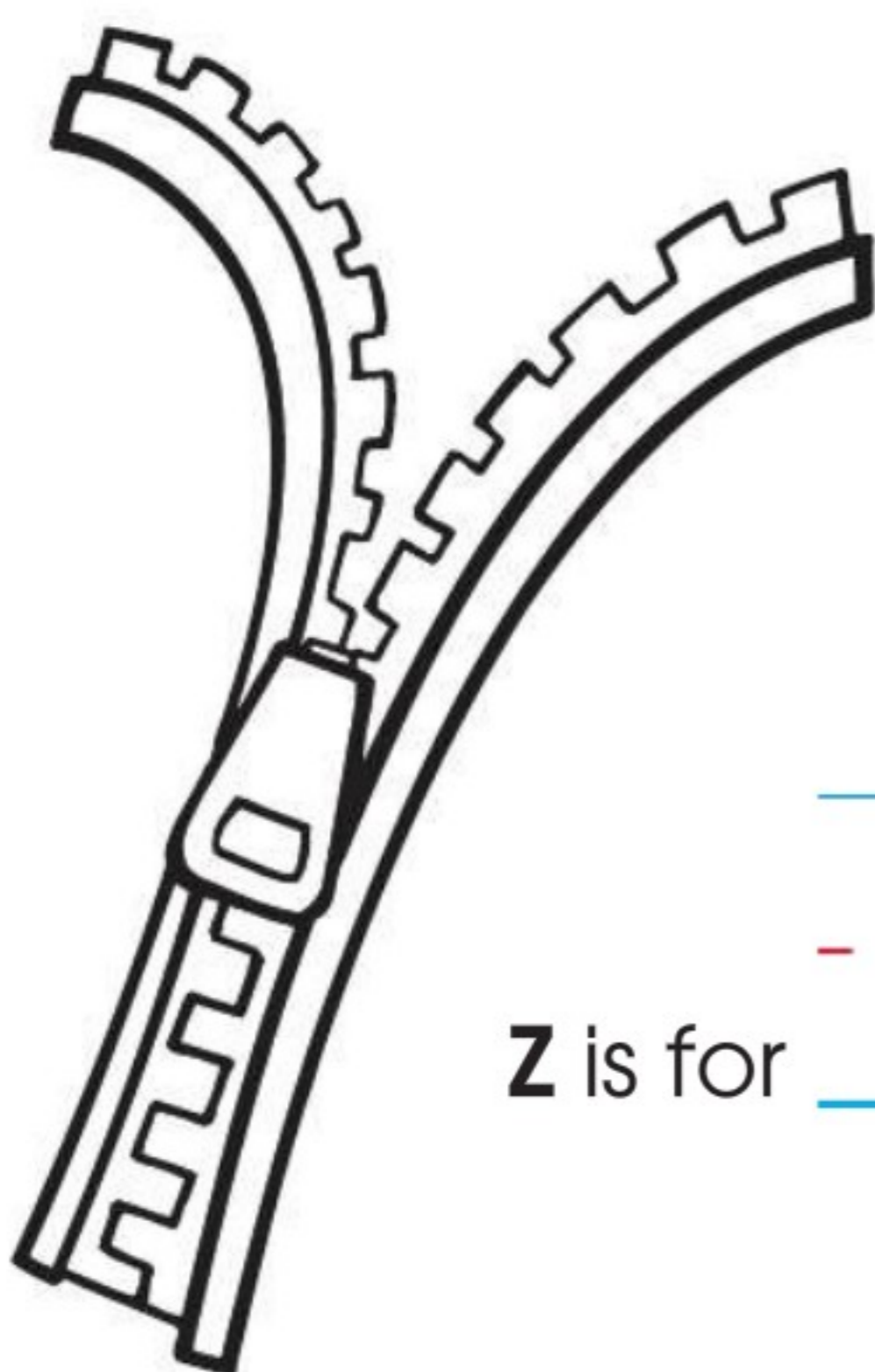

\_\_\_\_\_

-----

Z is for \_\_\_\_\_ipper.

\_\_\_\_\_

-----

Z is for \_\_\_\_\_ig-zag.

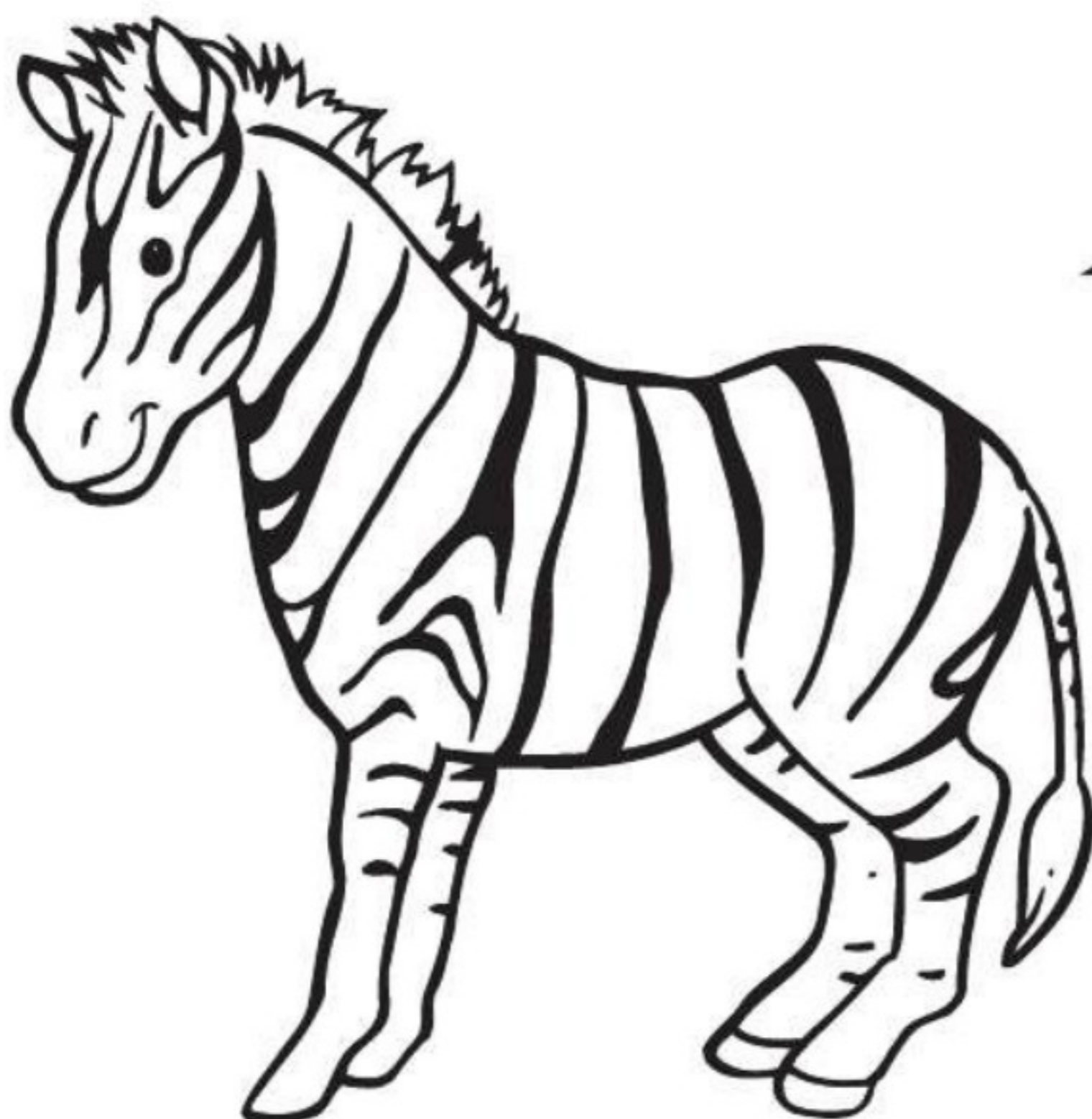

\_\_\_\_\_

-----

Z is for \_\_\_\_\_ebra.



## Review Letters Aa-Zz

**Directions:** Draw  lines to match the **UPPERCASE** and **lowercase** letters that go together.

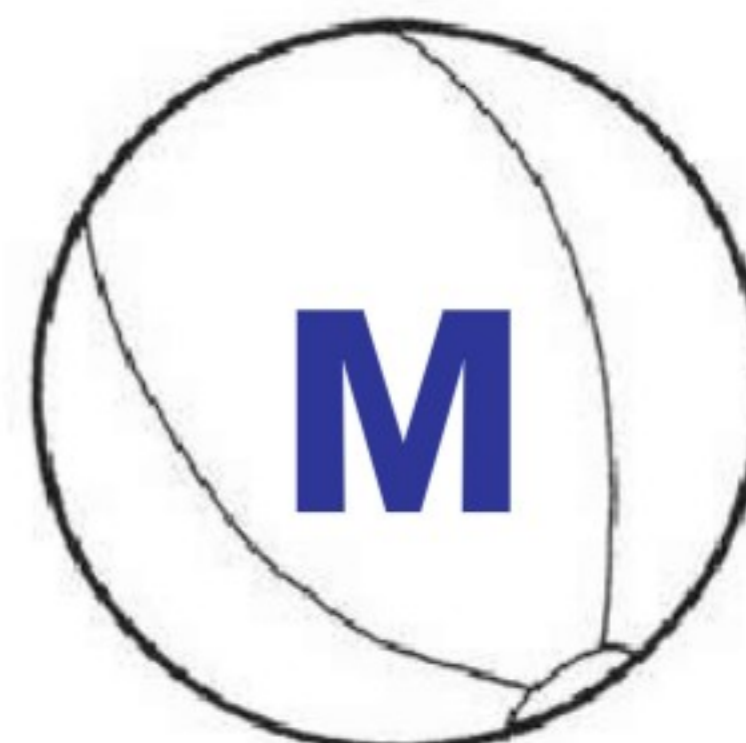
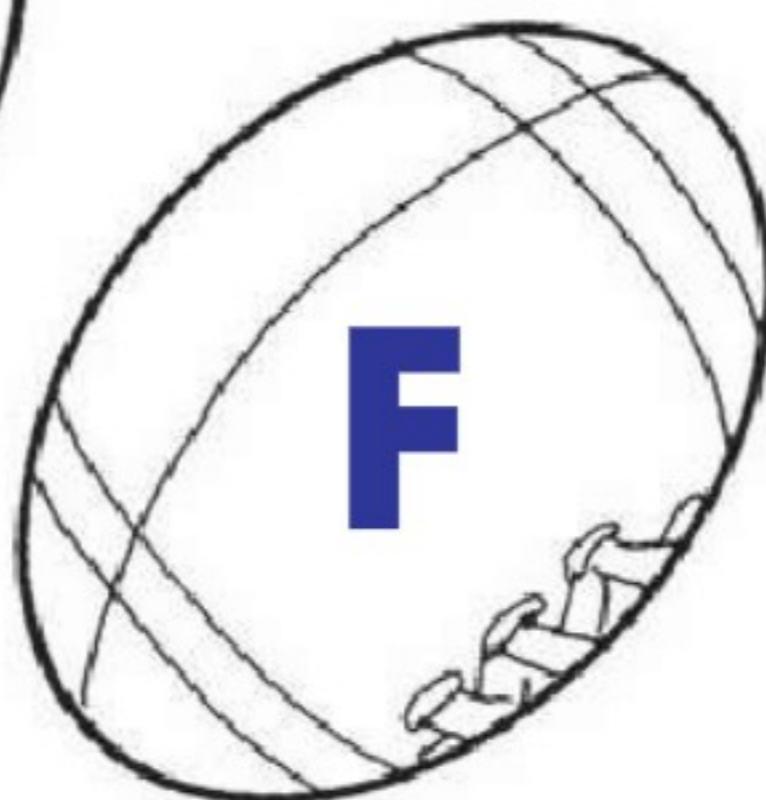
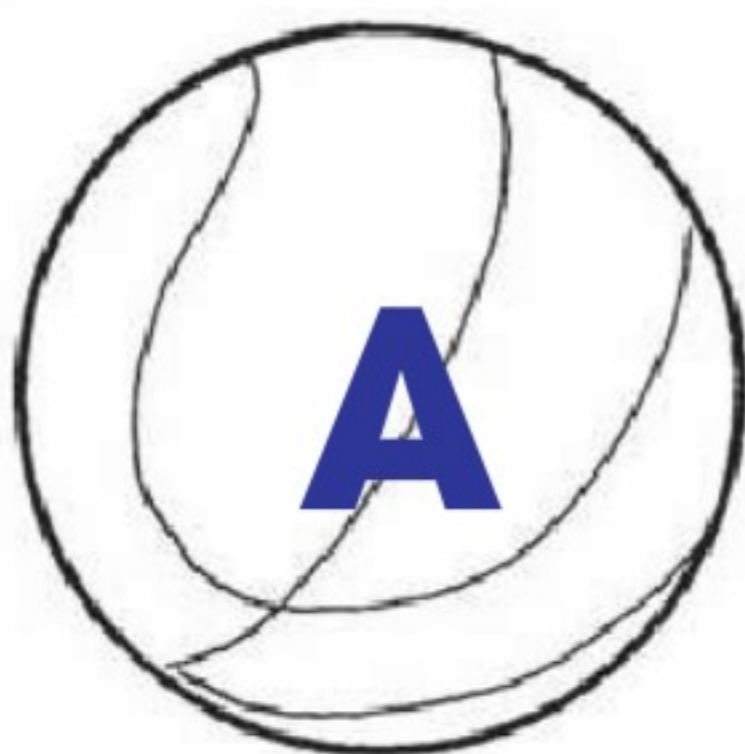
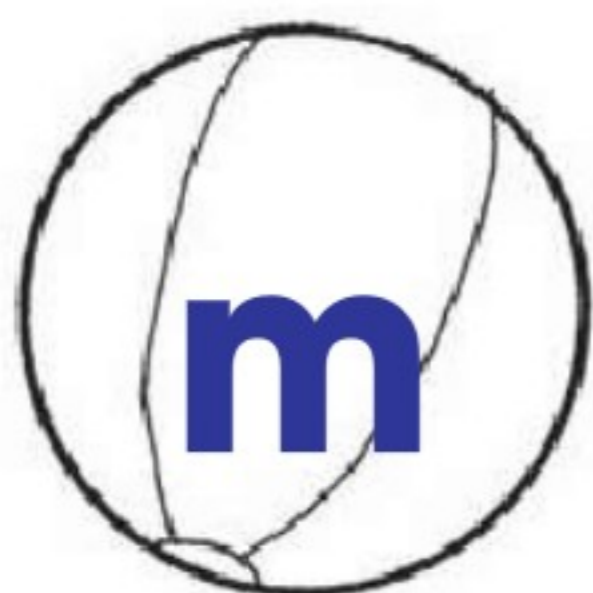



# Review Letters Aa-Zz

**Directions:** Draw  lines to match the **UPPERCASE** and **lowercase** letters that go together.

The image contains 12 sports balls arranged in a grid-like pattern. Each ball has a letter on it. The letters are: W (volleyball), v (soccer ball), X (baseball), z (tennis ball), y (tennis ball), U (volleyball), u (volleyball), Y (baseball), v (soccer ball), z (tennis ball), w (volleyball), and X (baseball).



# Review Letters Aa-Zz

**Directions:** Practice writing the letters **Aa-Ll** by tracing  the **UPPERCASE** and **lowercase** letters below.

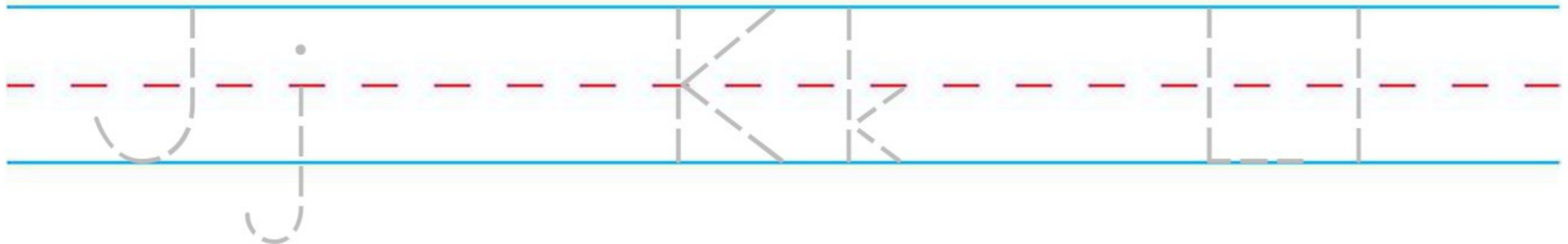
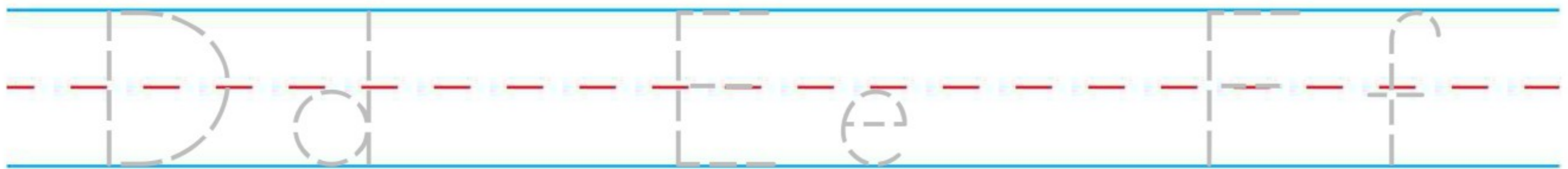
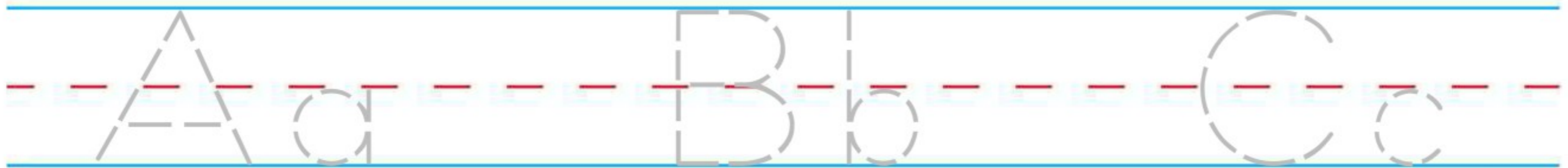
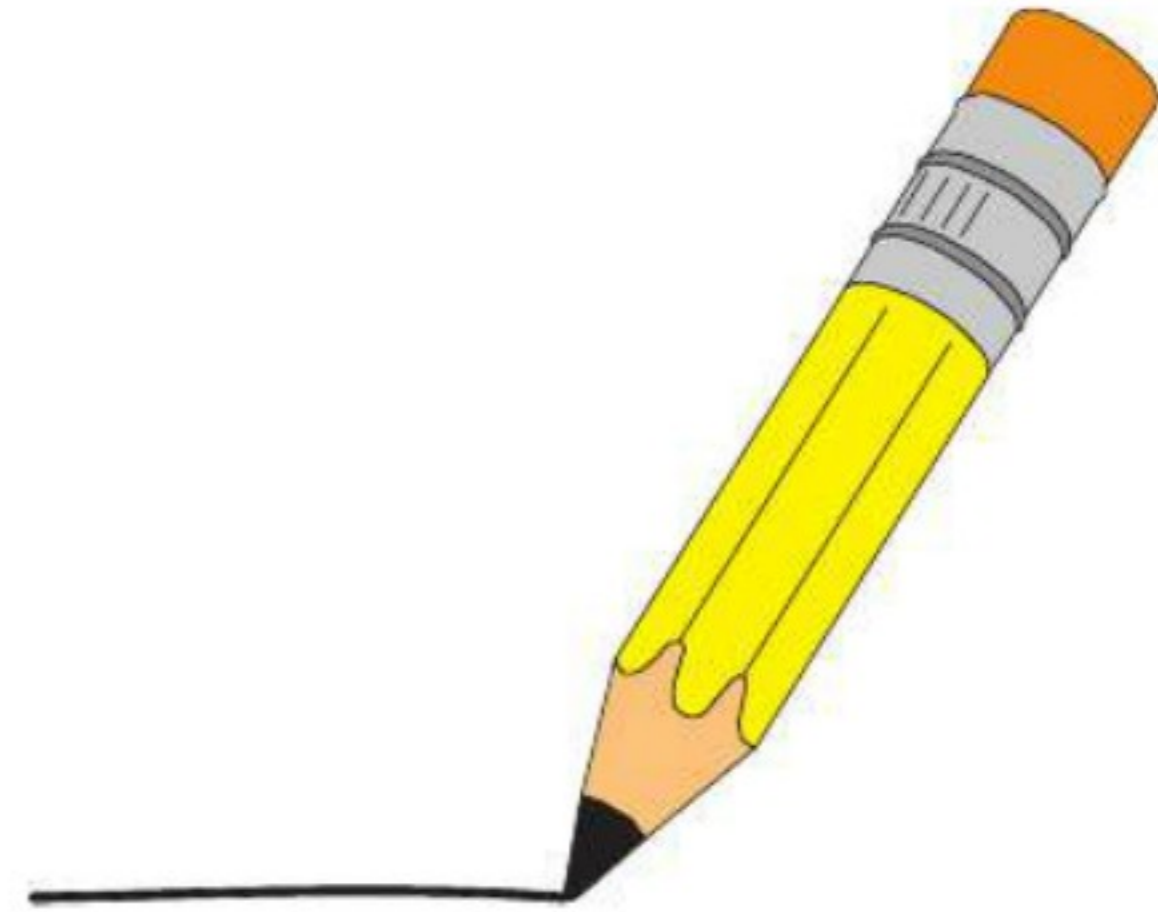





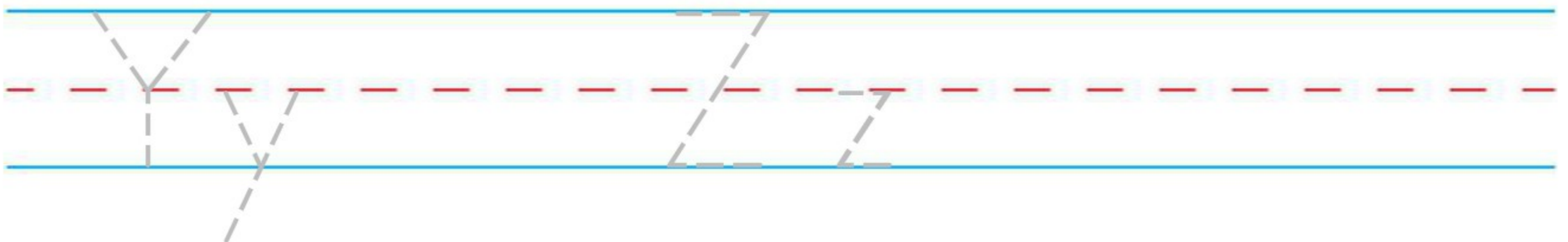
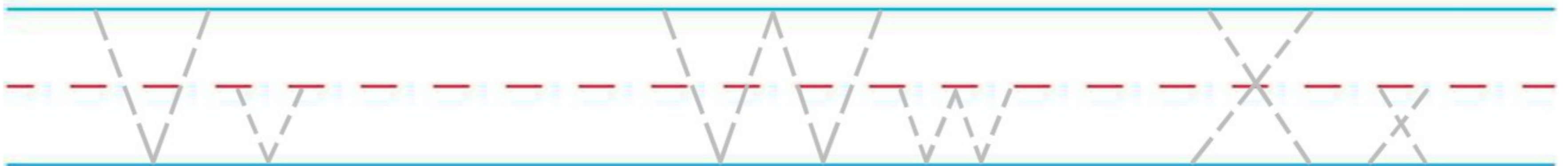
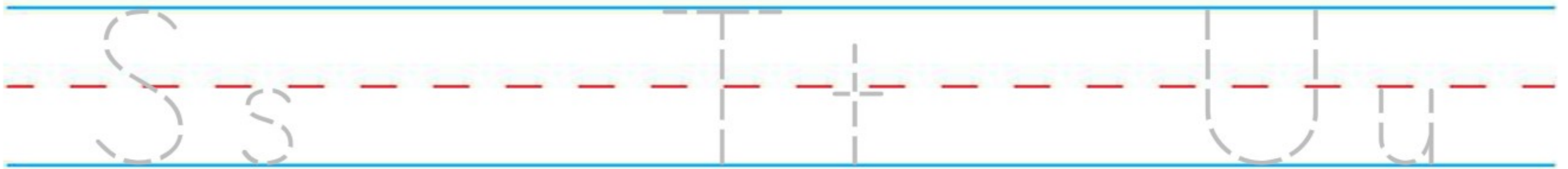
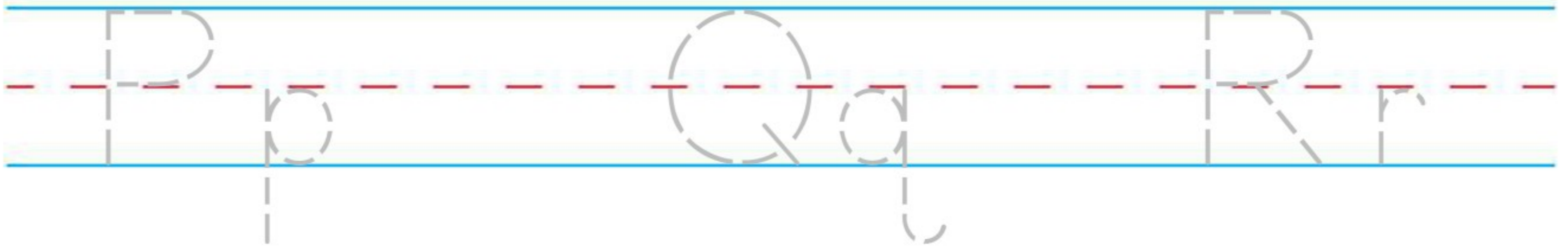
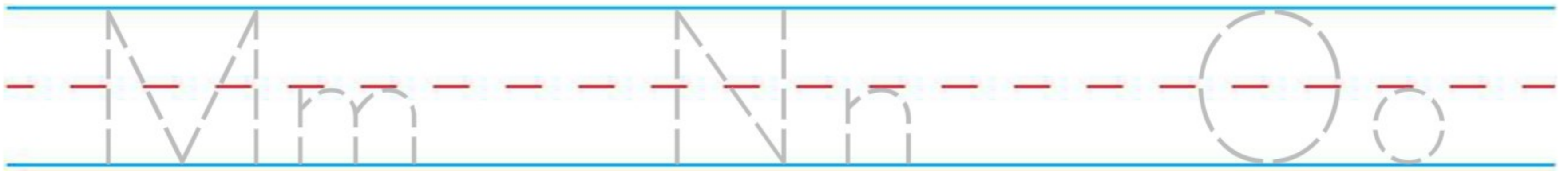
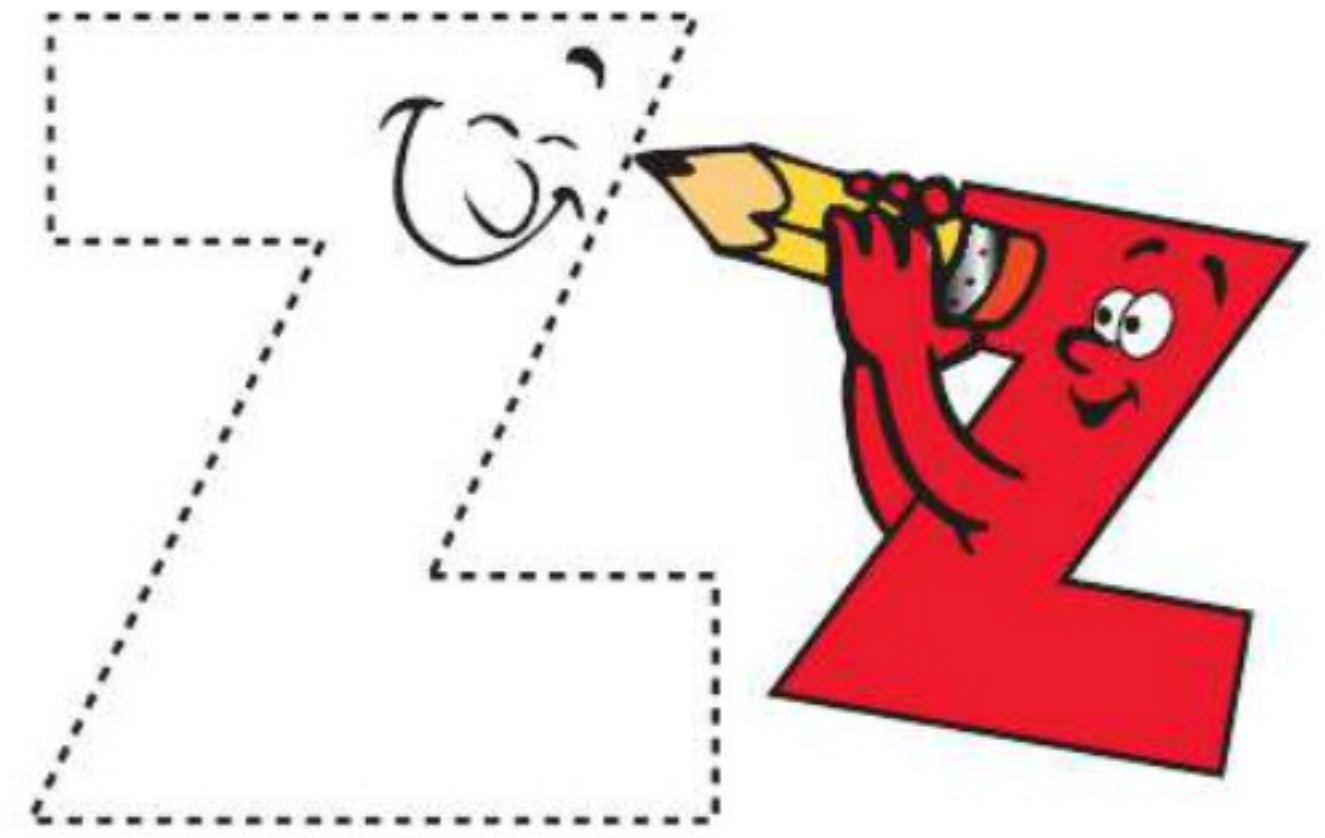

## Review Letters Aa-Zz

**Directions:** Practice writing the letters **Mm-Zz** by **tracing**  the **UPPERCASE** and **lowercase** letters below.





# Review Letters A-Z

**Directions:** Grandparents are fun to visit.  Draw a line from **A-Z** to show the way to the grandparents' house.

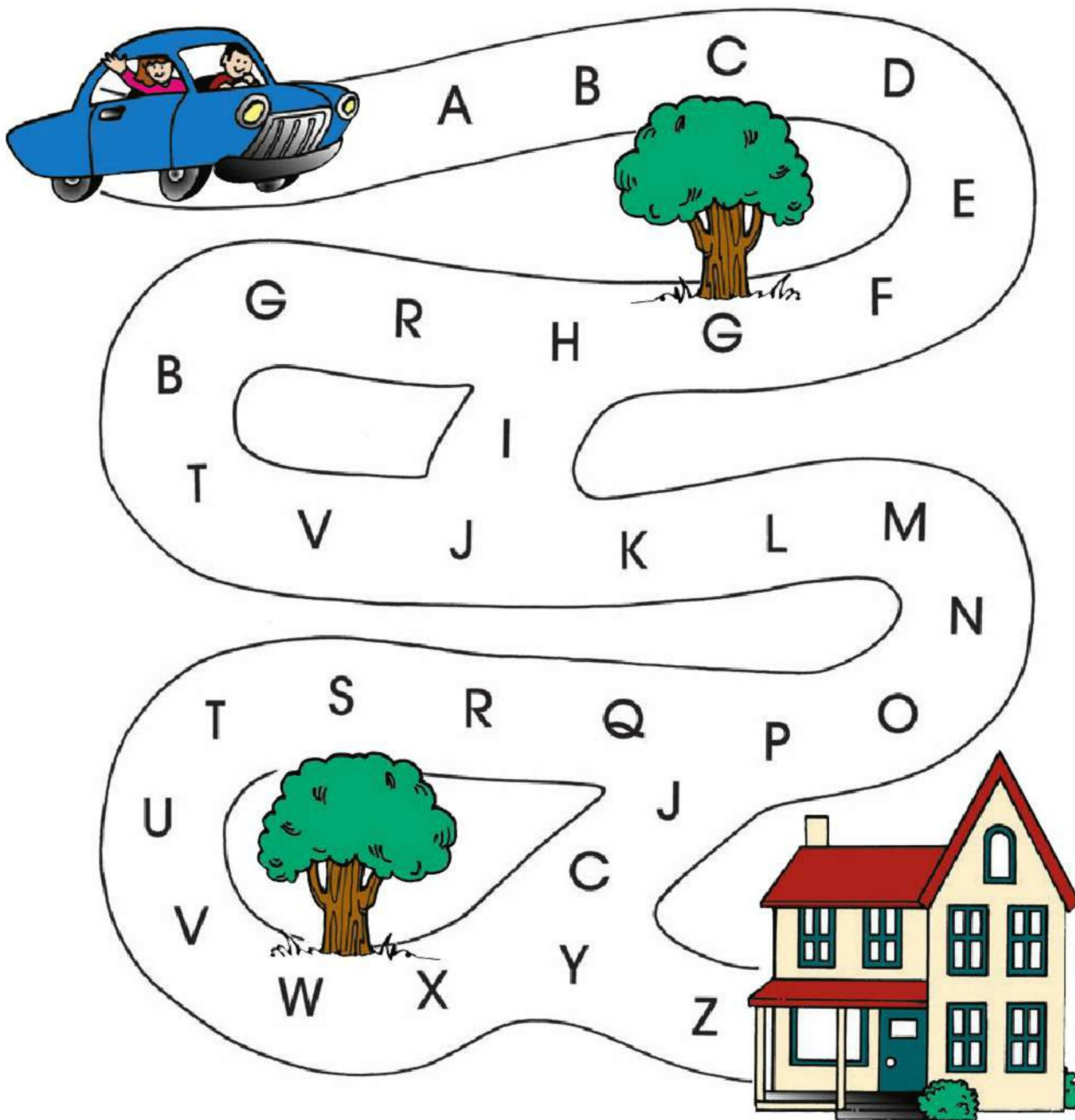



## Review Letters a-z

**Directions:** Connect  the dots as you say the alphabet, starting with the letter **a**. Color  the picture.





## Stop Making Sense!

Look at the picture. A lot of silly things are happening!

**Directions:** Circle  all of the things that do **not** make sense.





## Ben's New Sister

**Directions:** Ben is going to see his new baby sister for the first time! Ben and his dad are at the hospital looking at all the sleeping babies. Use the clues to find out which baby is Ben's new sister. Then, **circle**  your choice.

Ben's sister is not bald.

Ben's sister has a yellow blanket.

Ben's sister has dark hair.





# Color It In!

**Directions:** Color  the 1 picture in each row that both words describe.

**soft and cold**

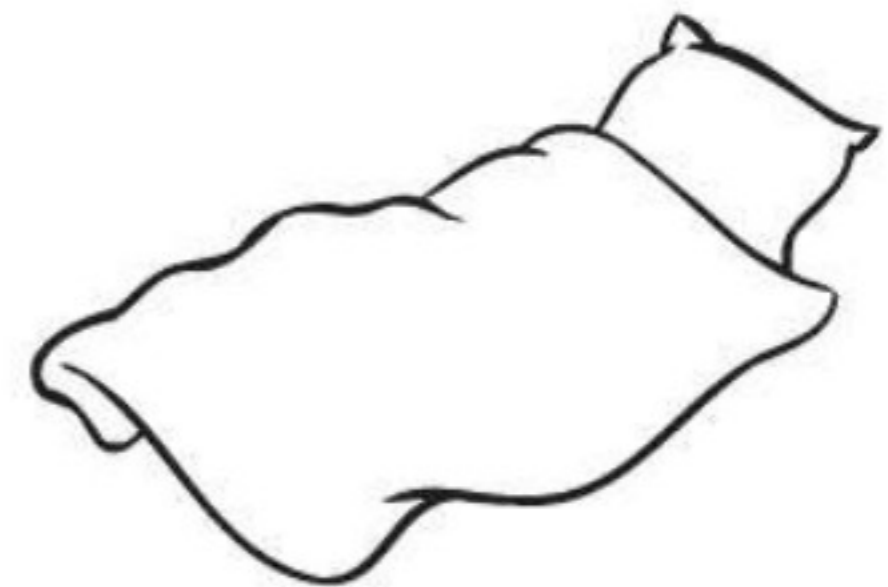
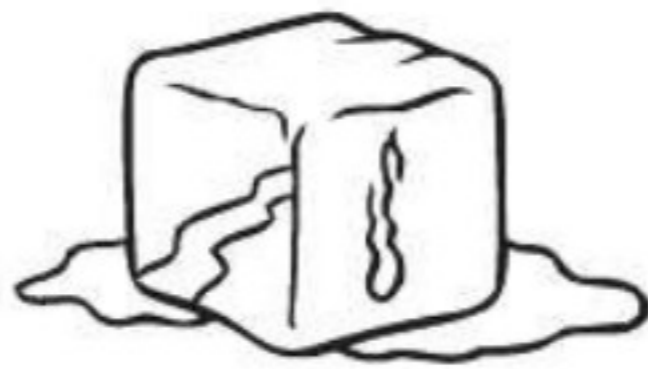

**tall and large**

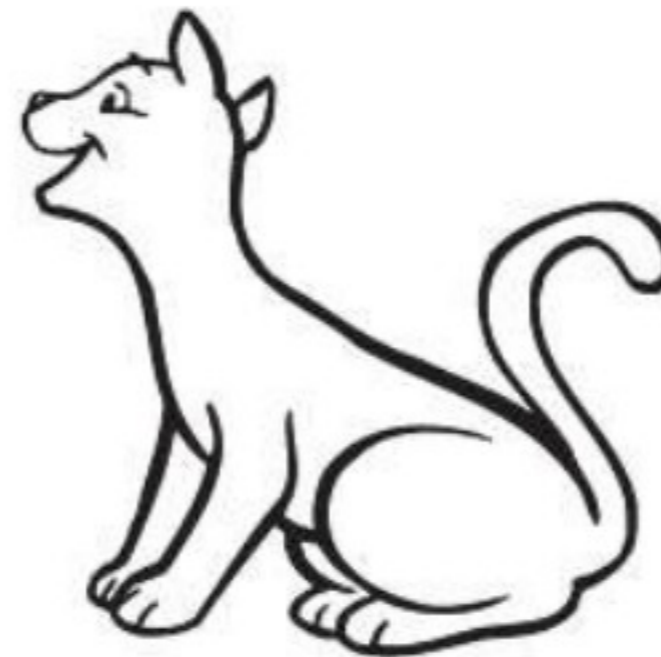
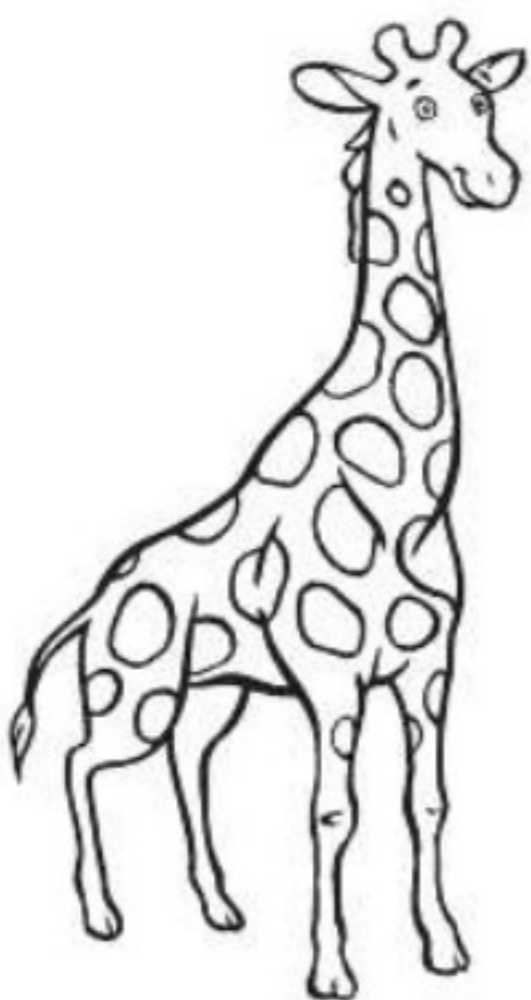

**hot and round**

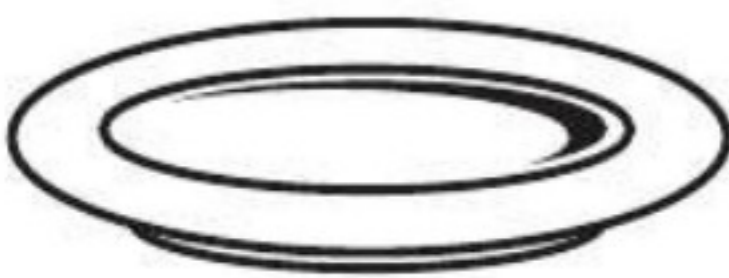

**shiny and hard**

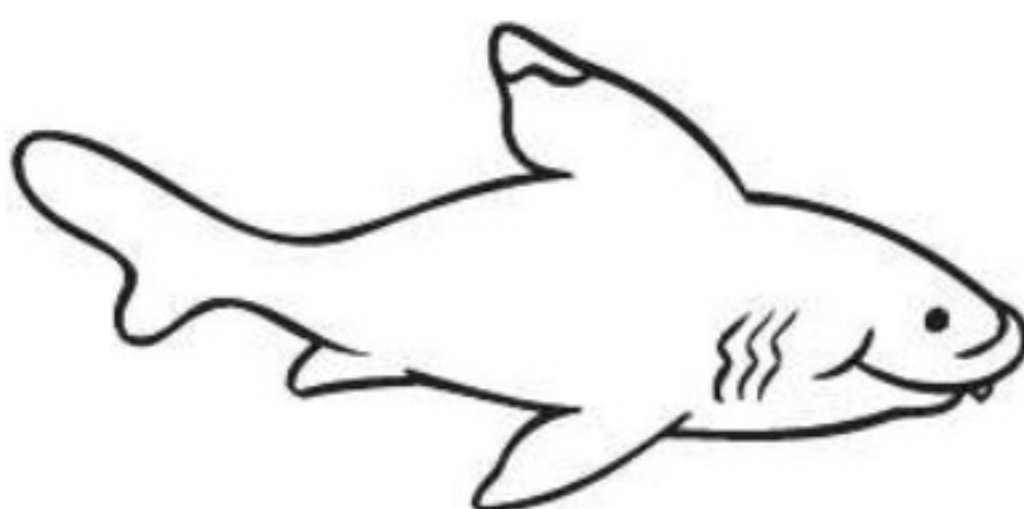



# Color It in Again!

**Directions:** Color  the 1 picture in each row that both words describe.

**square** and **hard**

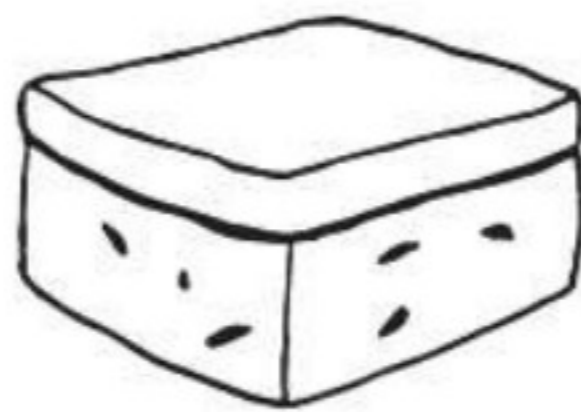

**sticky** and **pink**

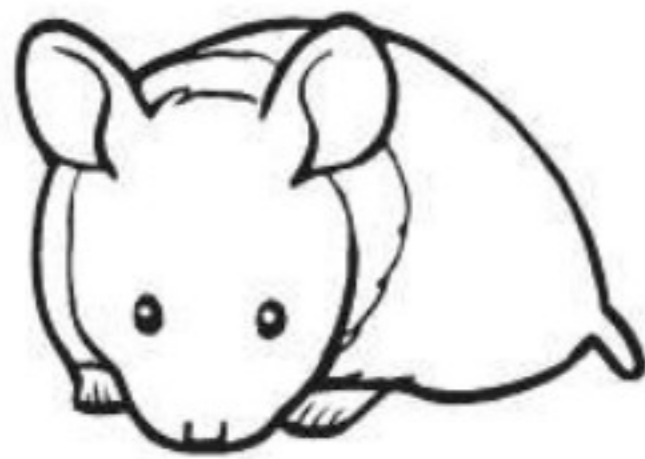

**smooth** and **cold**

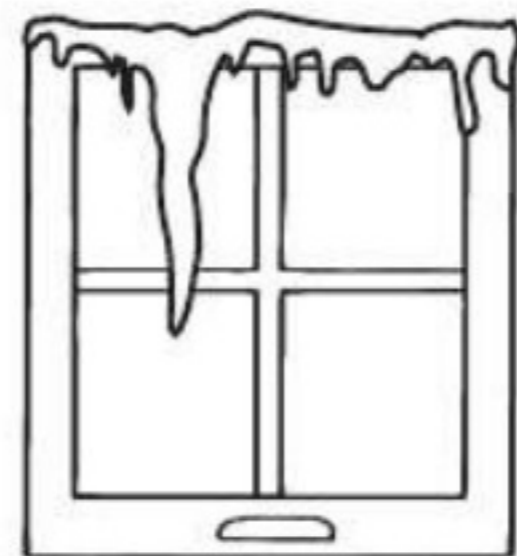
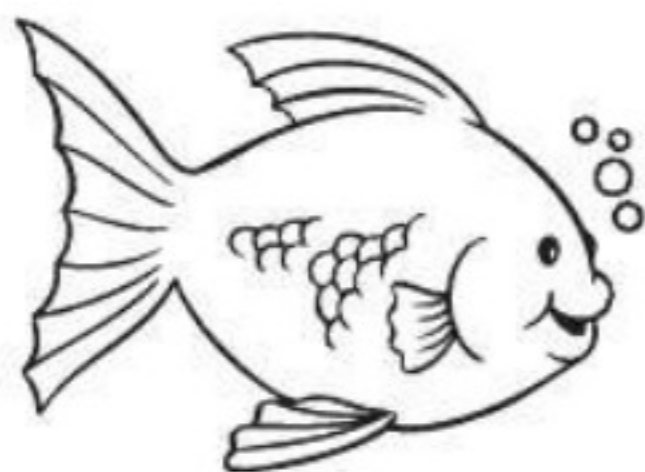

**wet** and **large**

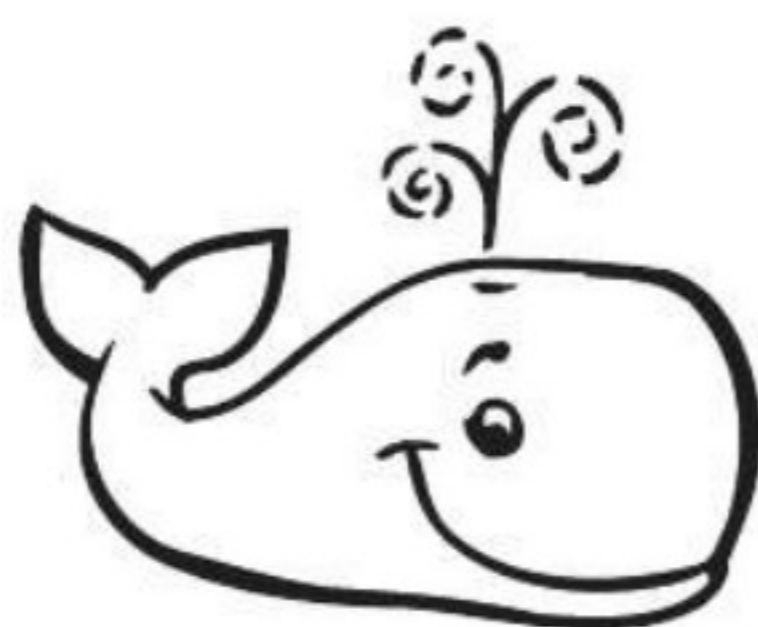



## Find the Right Picture

**Directions:** Which picture goes with the sentence? **Circle**  the correct picture.

The 3 little pigs had a picnic in the tree to escape from the big bad wolf.







## Find the Right Picture

**Directions:** Which picture goes with the sentence? **Circle**  the correct picture.

Marilyn and Mindy went on a Ferris wheel ride with their parents.





# Which Picture Is Missing?

**Directions:** Look at the pictures below. There is a picture missing.

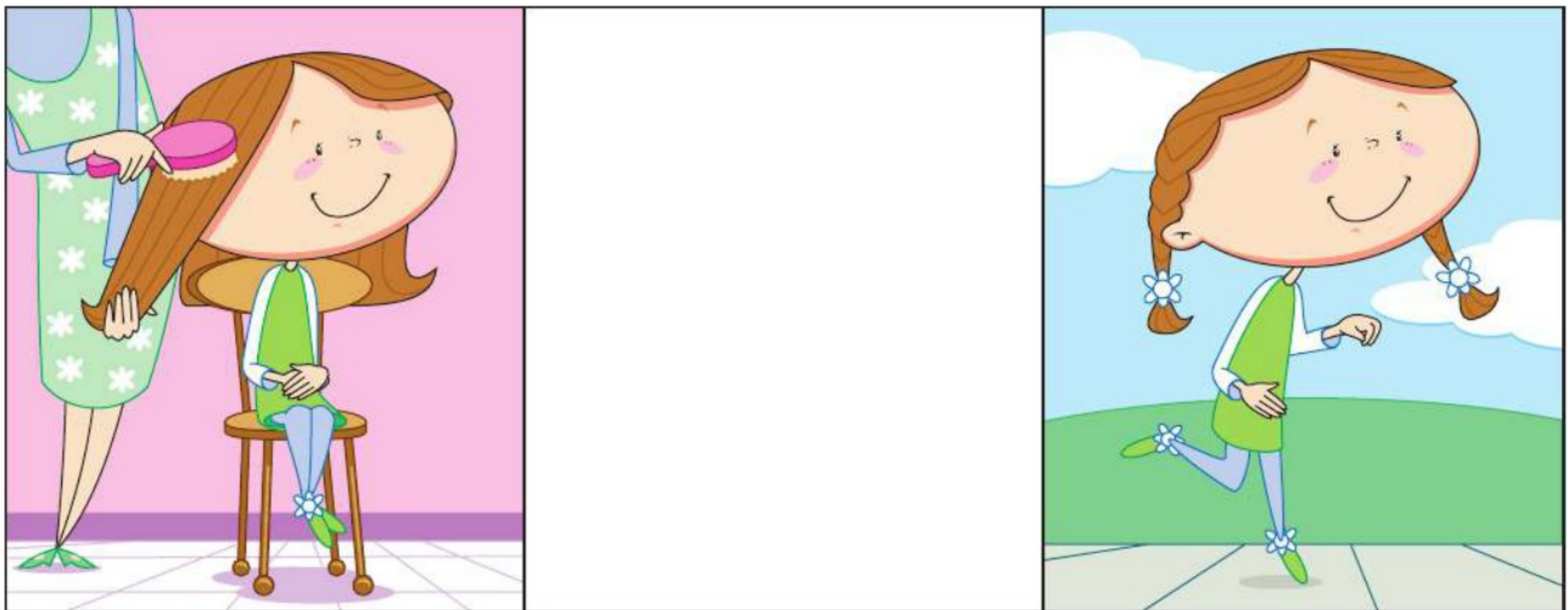

**Circle**  the missing picture.

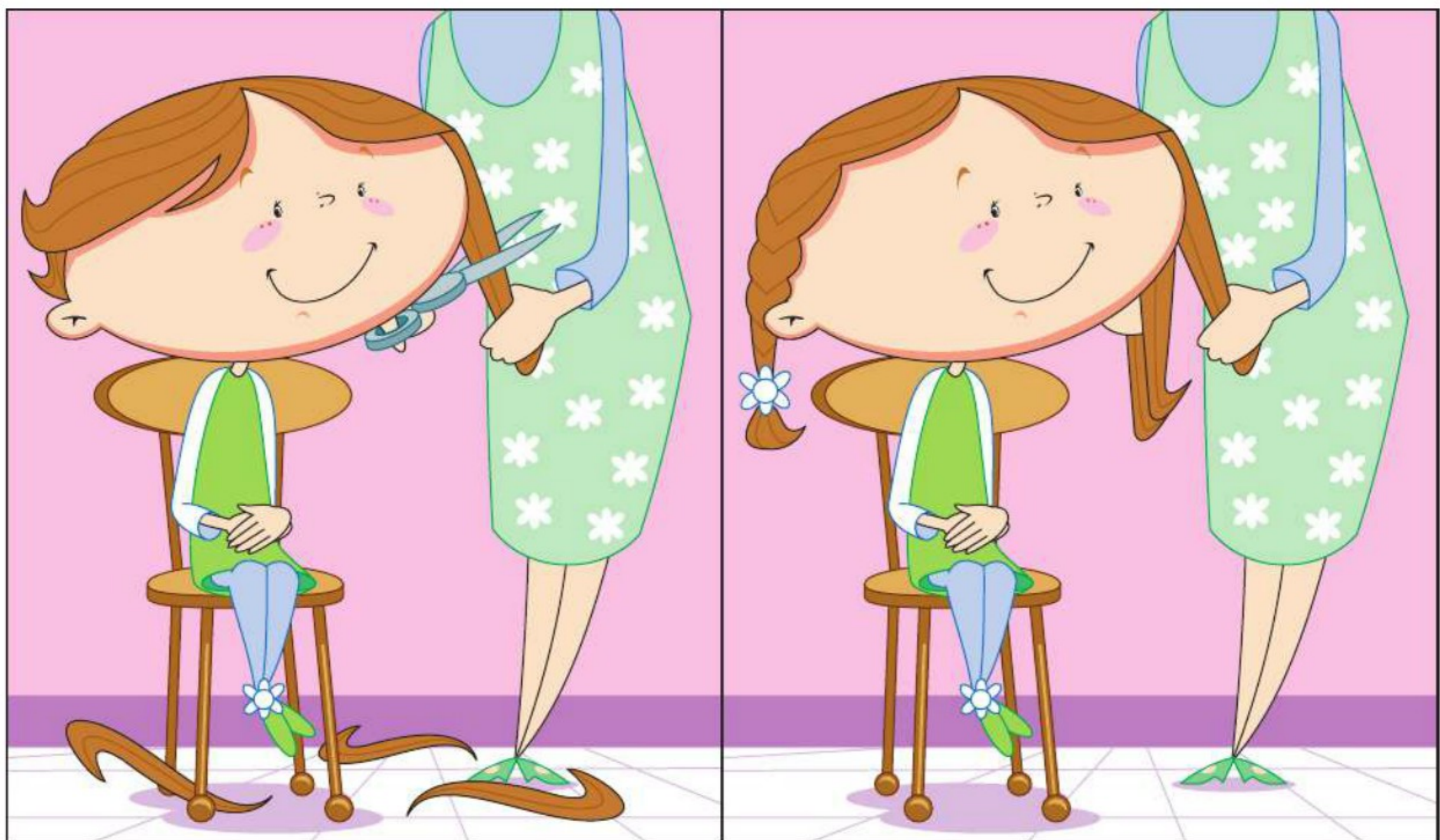



# Which Picture Is Missing?

**Directions:** Look at the pictures below. There is a picture missing.

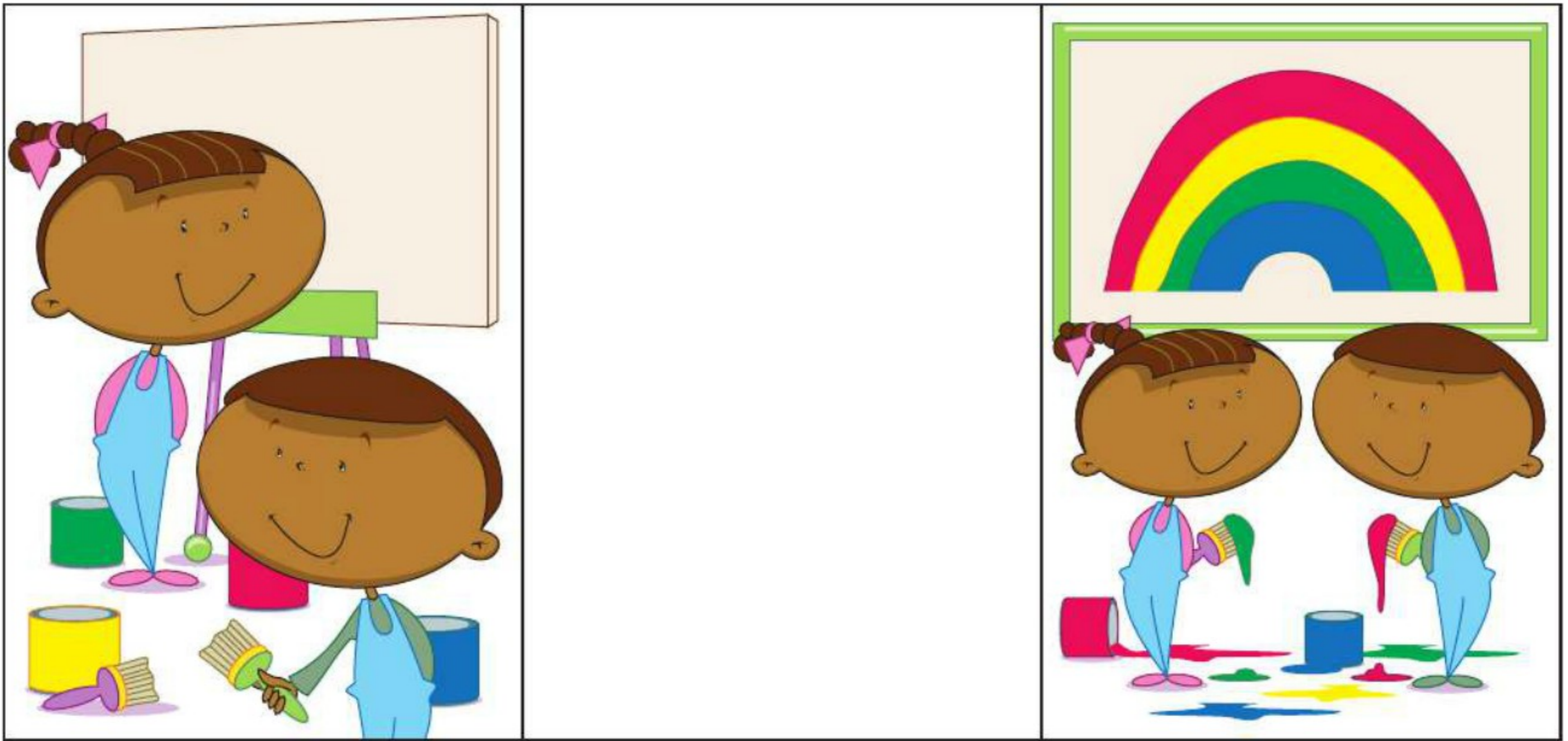

**Circle**  the missing picture.

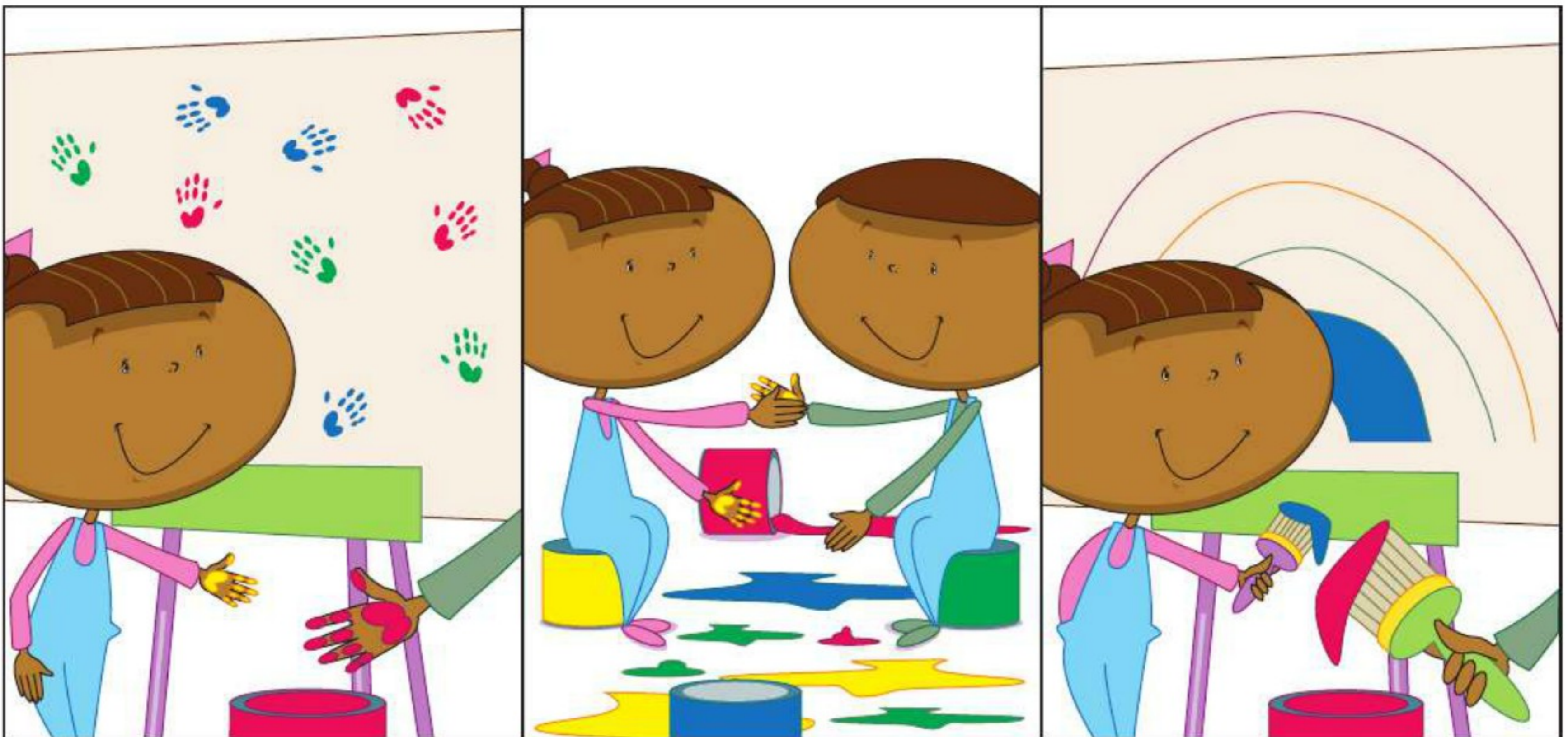



# Puppy Needs

Marcy and her dad want to build a doghouse for their new puppy.

**Directions:** Draw an X  on the things they will **not** need.

Then, **draw**  pictures of some other things they might need.





## Super Ice-Cream Sundaes!

Janet and her mom want to make ice-cream sundaes.

**Directions:** Draw an X  on the things they will **not** need.

Then, **draw**  pictures of some other things they might need.

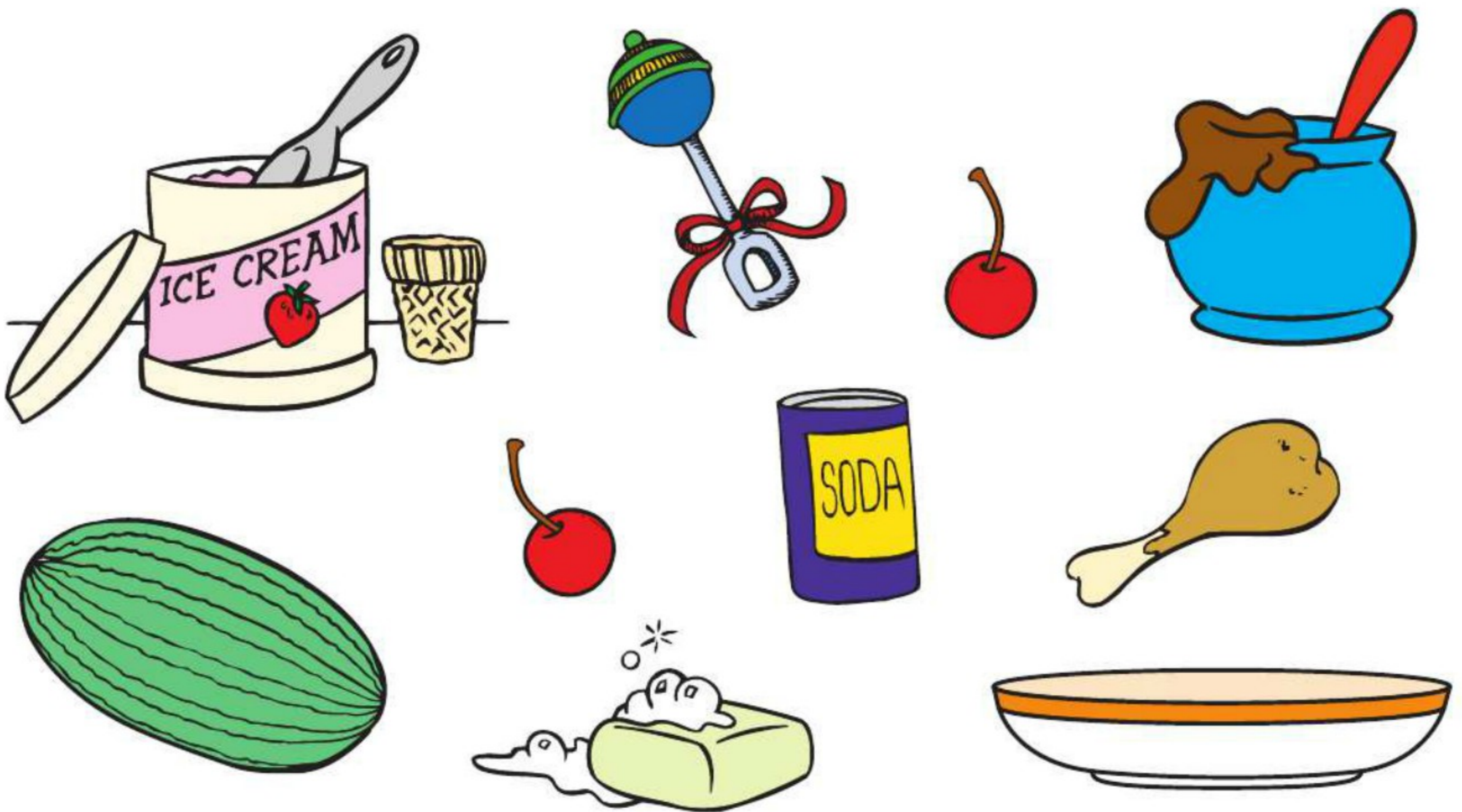



## What Will Happen Next?

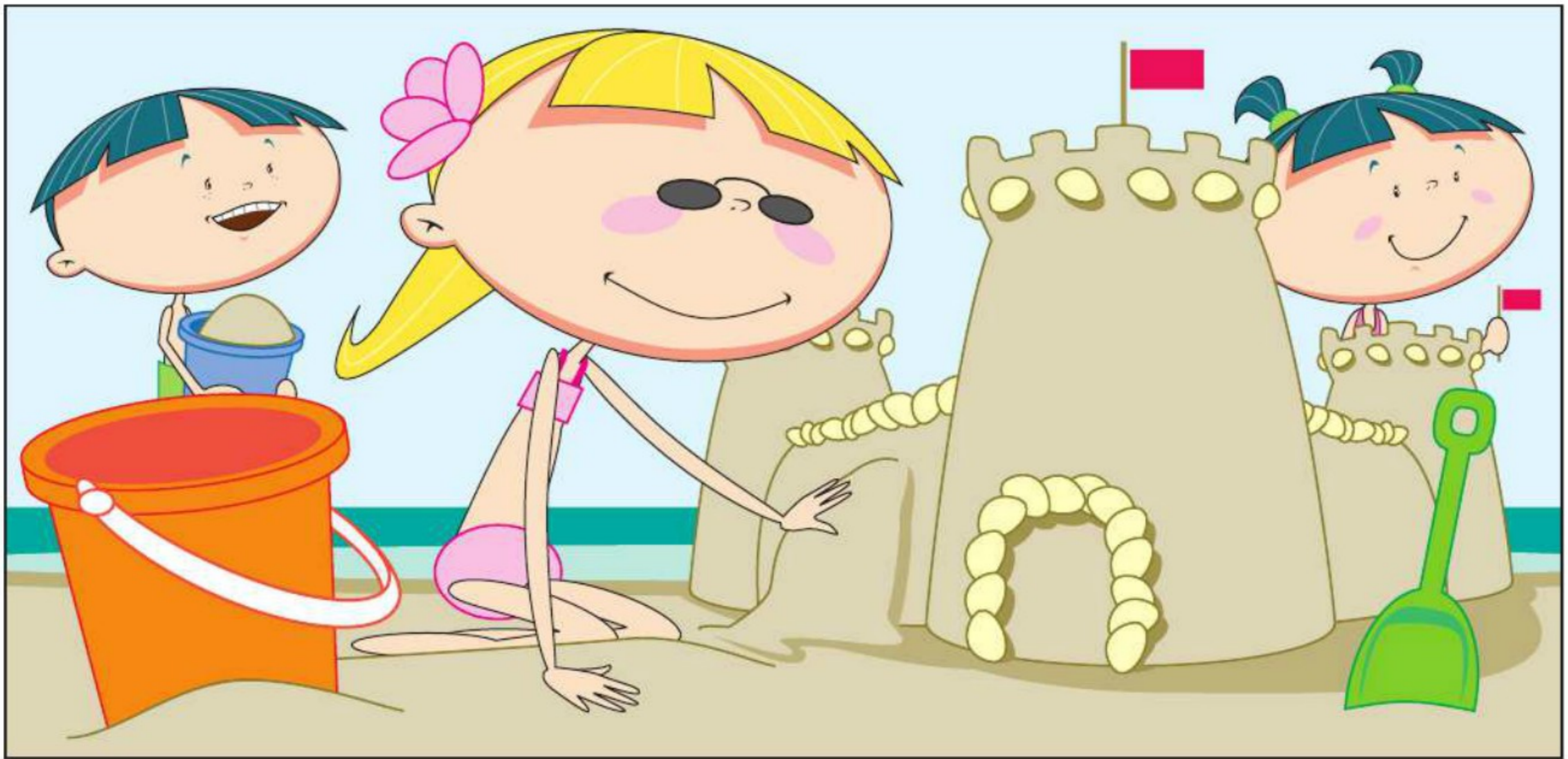

**Directions:** Look at the picture above. Now, **circle**  the picture below that shows what happens next.





## What's Next?



**Directions:** Look at the picture above. Now, **circle**  the picture below that shows what happens next.





## Tim's Turtle

**Directions:** Help Tim pick out a turtle at the pet shop.

Tim does **not** want a turtle with circles on its back.

Tim does **not** want a green turtle.

Tim does **not** want a turtle with triangles on its back.

**Circle**  the turtle that Tim should pick.

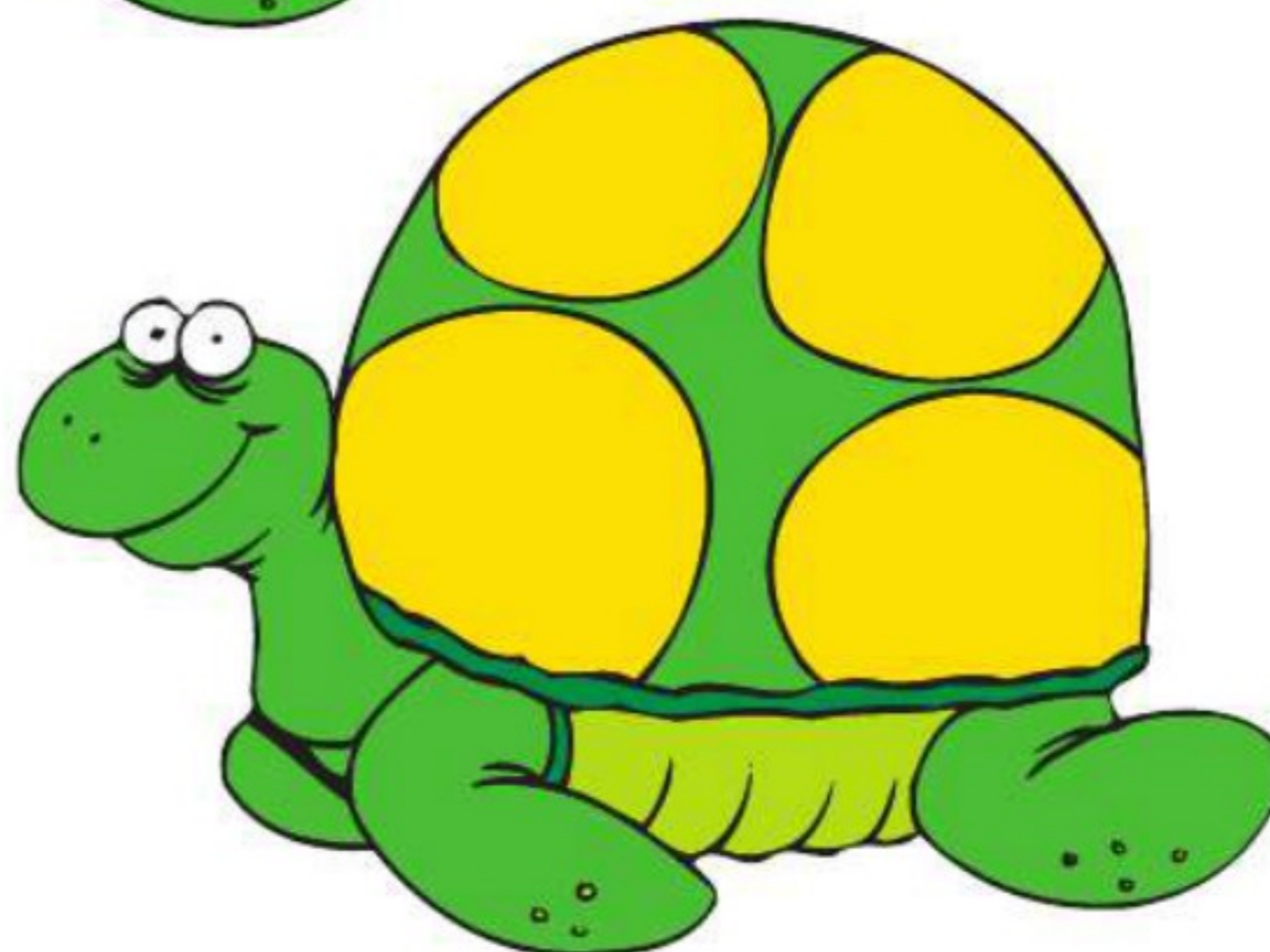
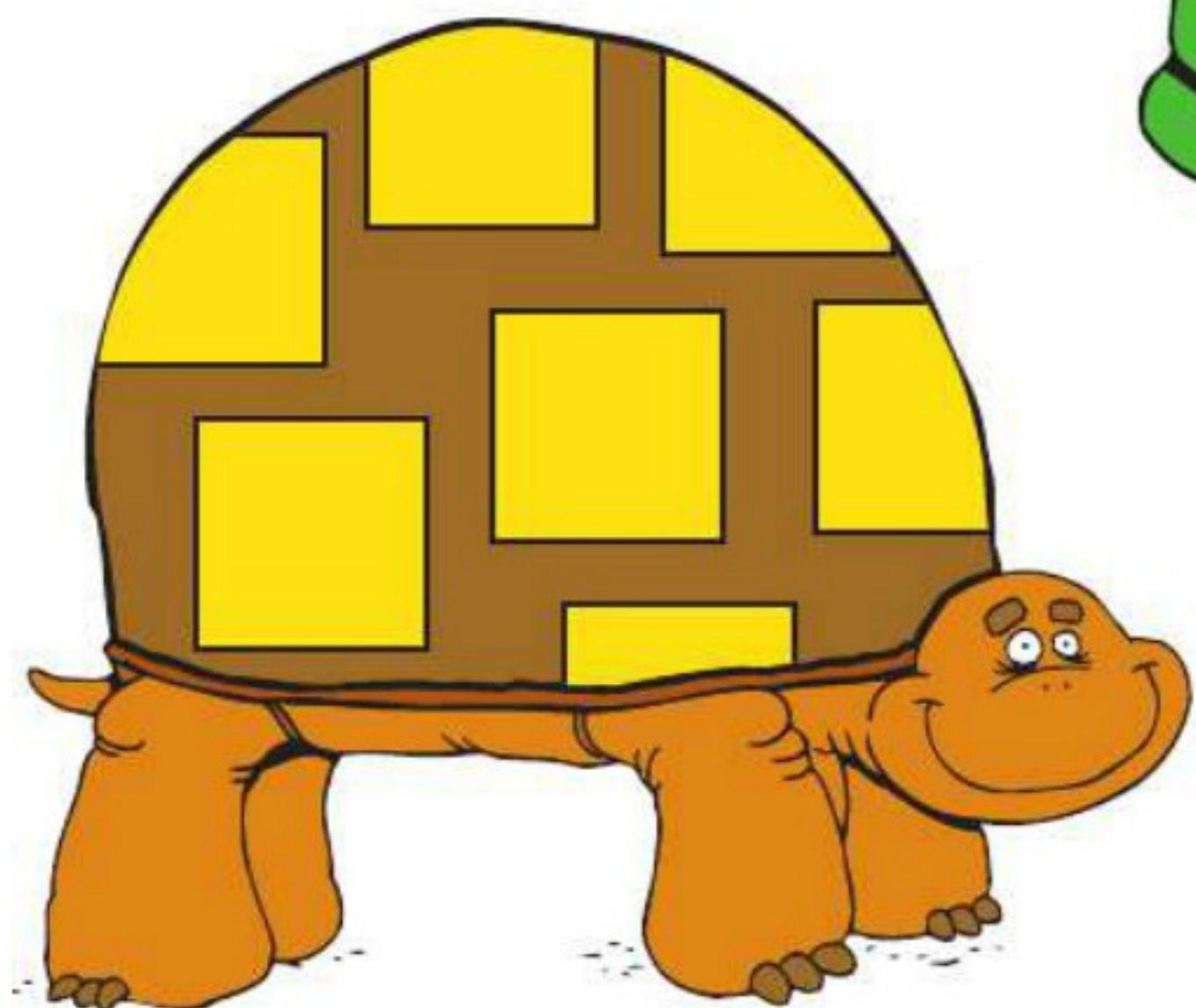
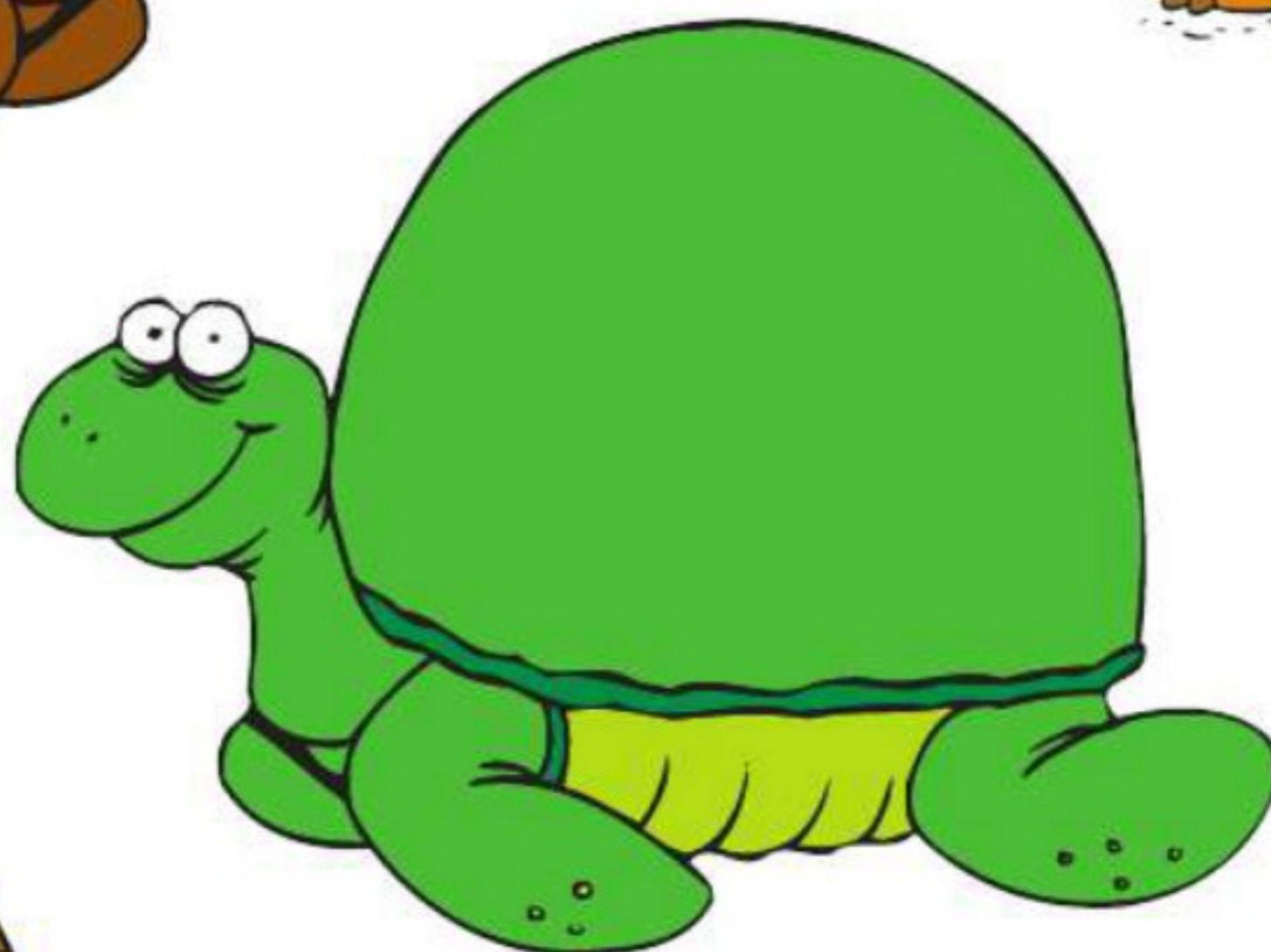
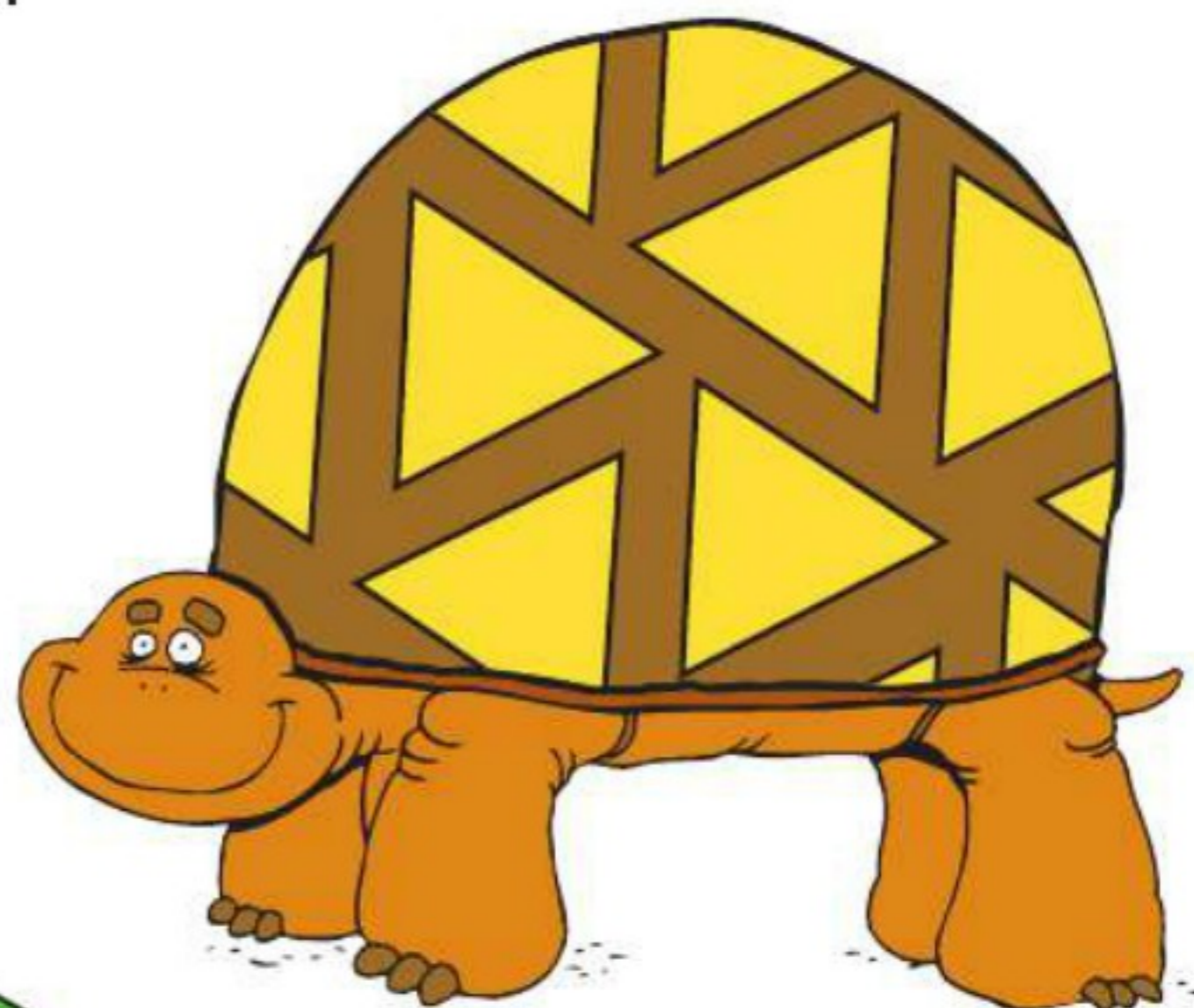
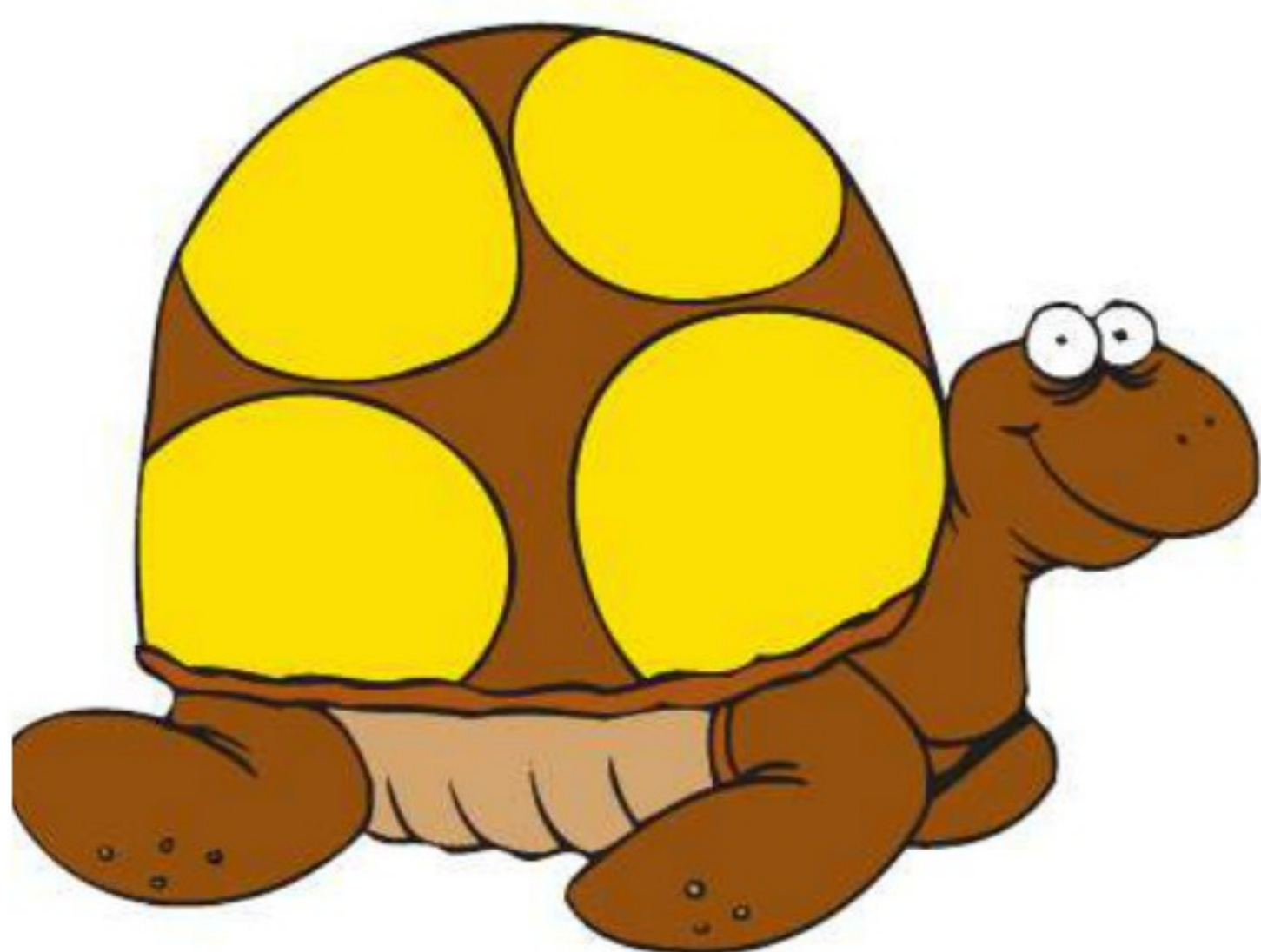



What should Tim name his turtle?





# Critical Thinking

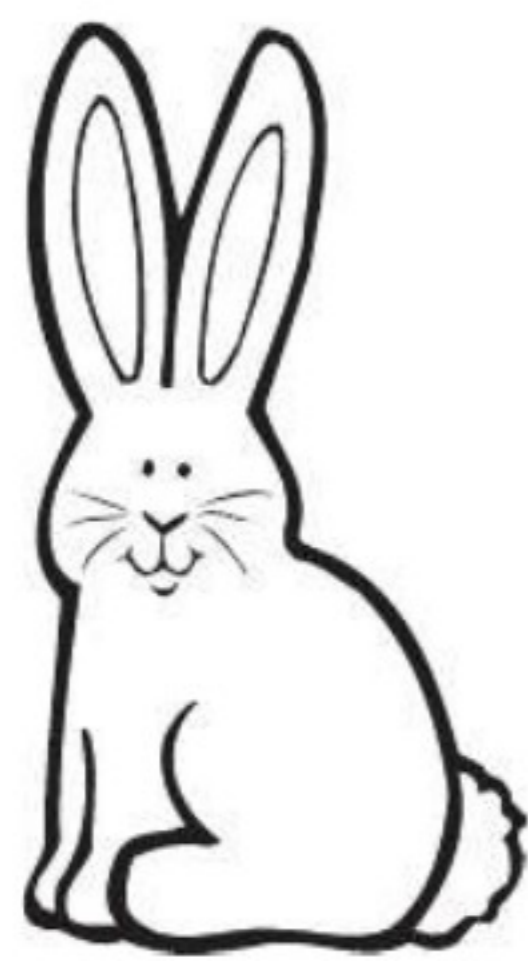
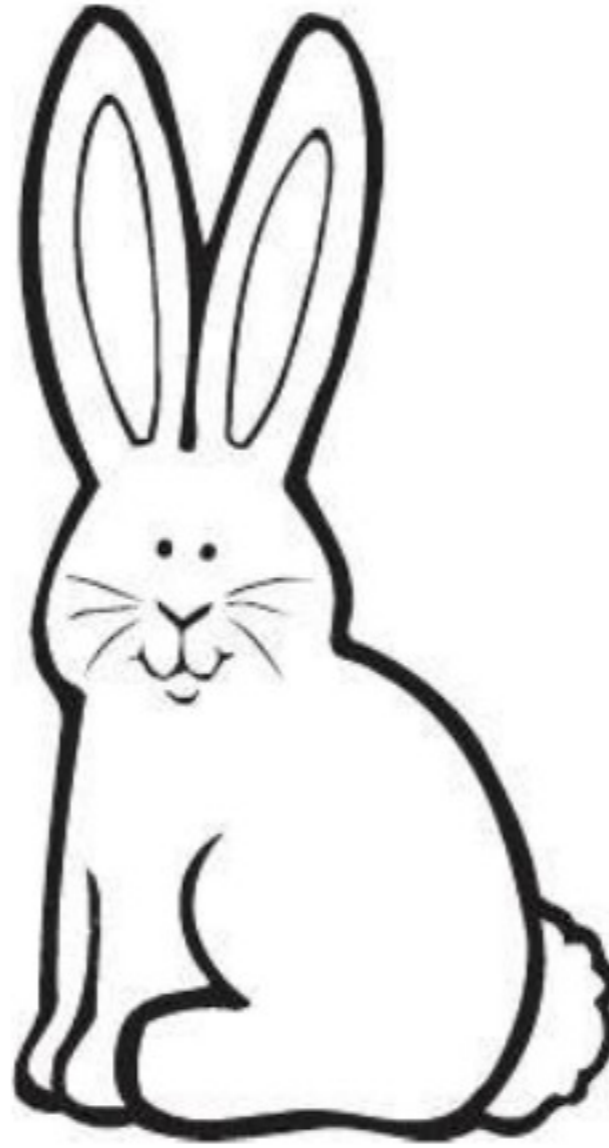
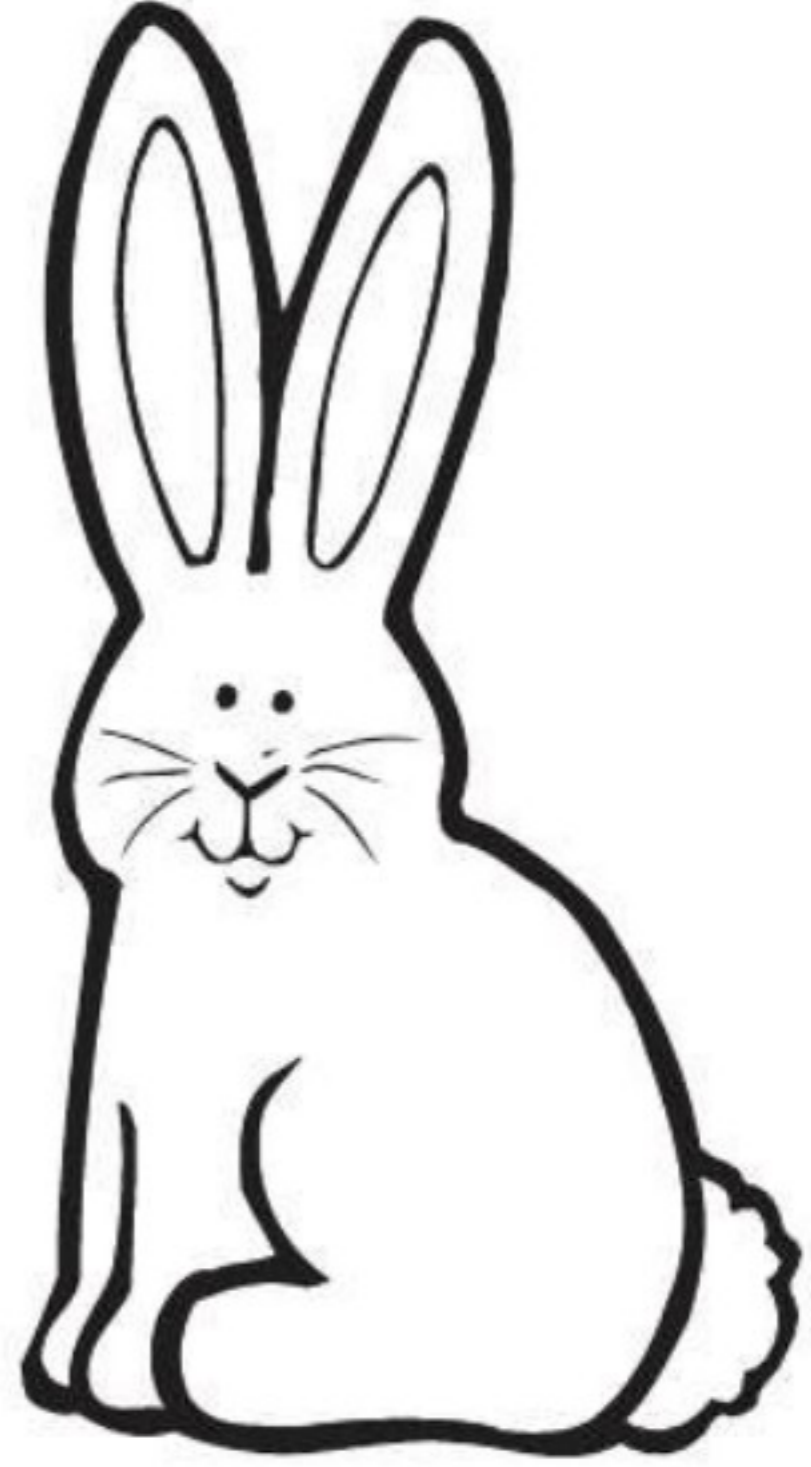

**Directions:** Let your child **color**  and **cut**  apart the cards below. Then, have him or her put the cards in a straight line according to size.





## Critical Thinking

**Directions:** Let your child **draw**  and **color**  details on the trees below according to each season of the year. Then, have him or her **cut**  the cards apart and put them in correct order. Fasten them together to make a book.



**SUMMER**

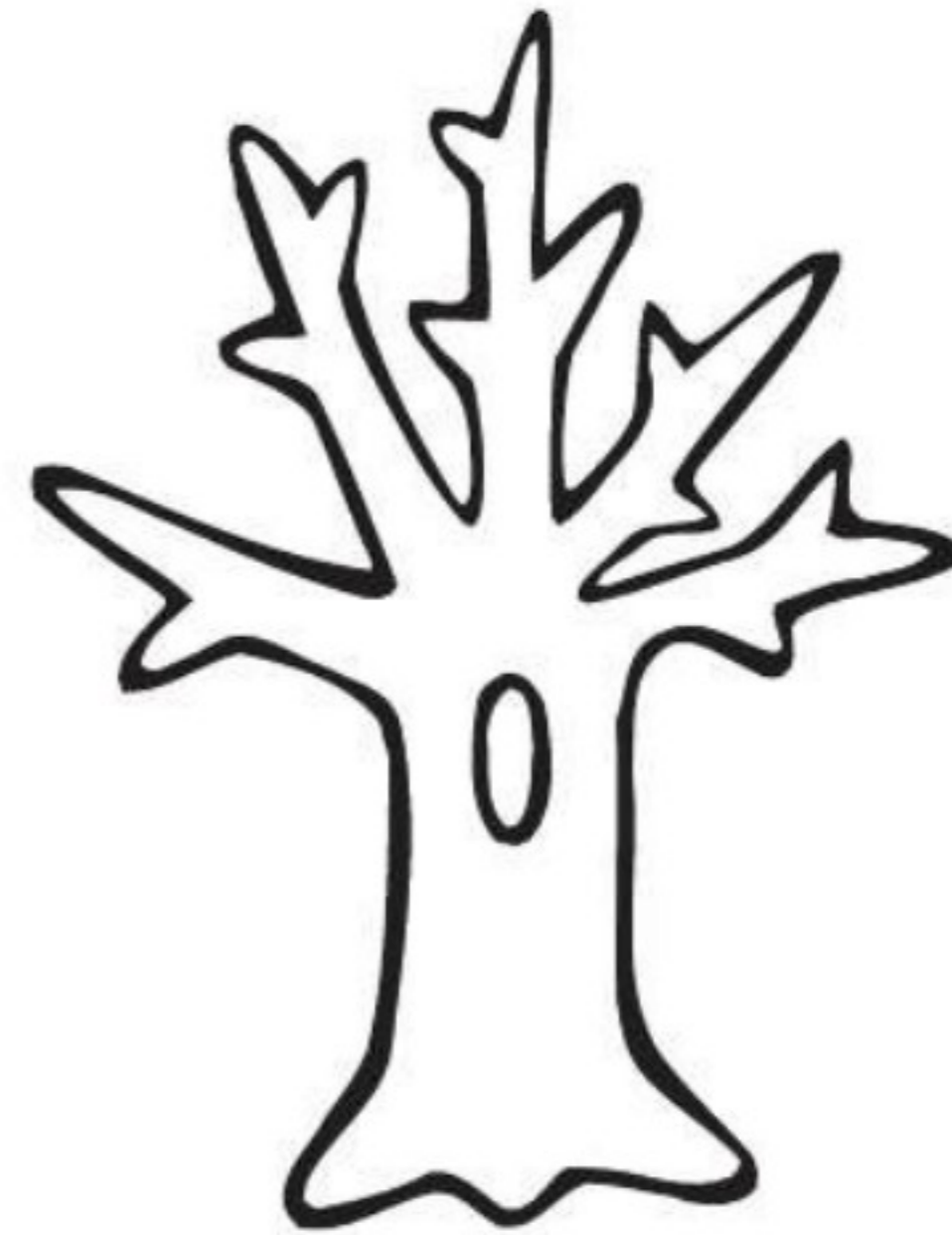

**AUTUMN**

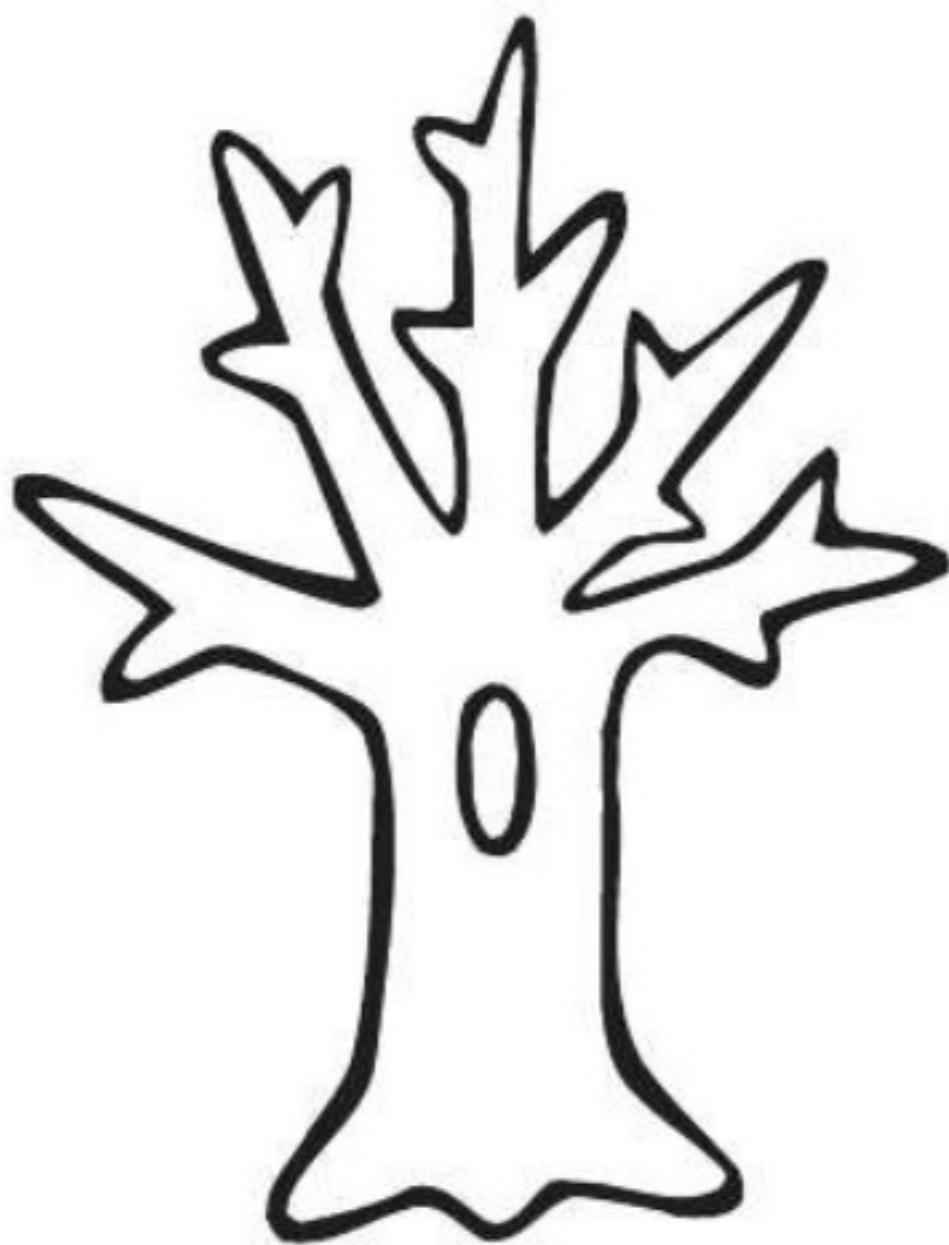

**WINTER**

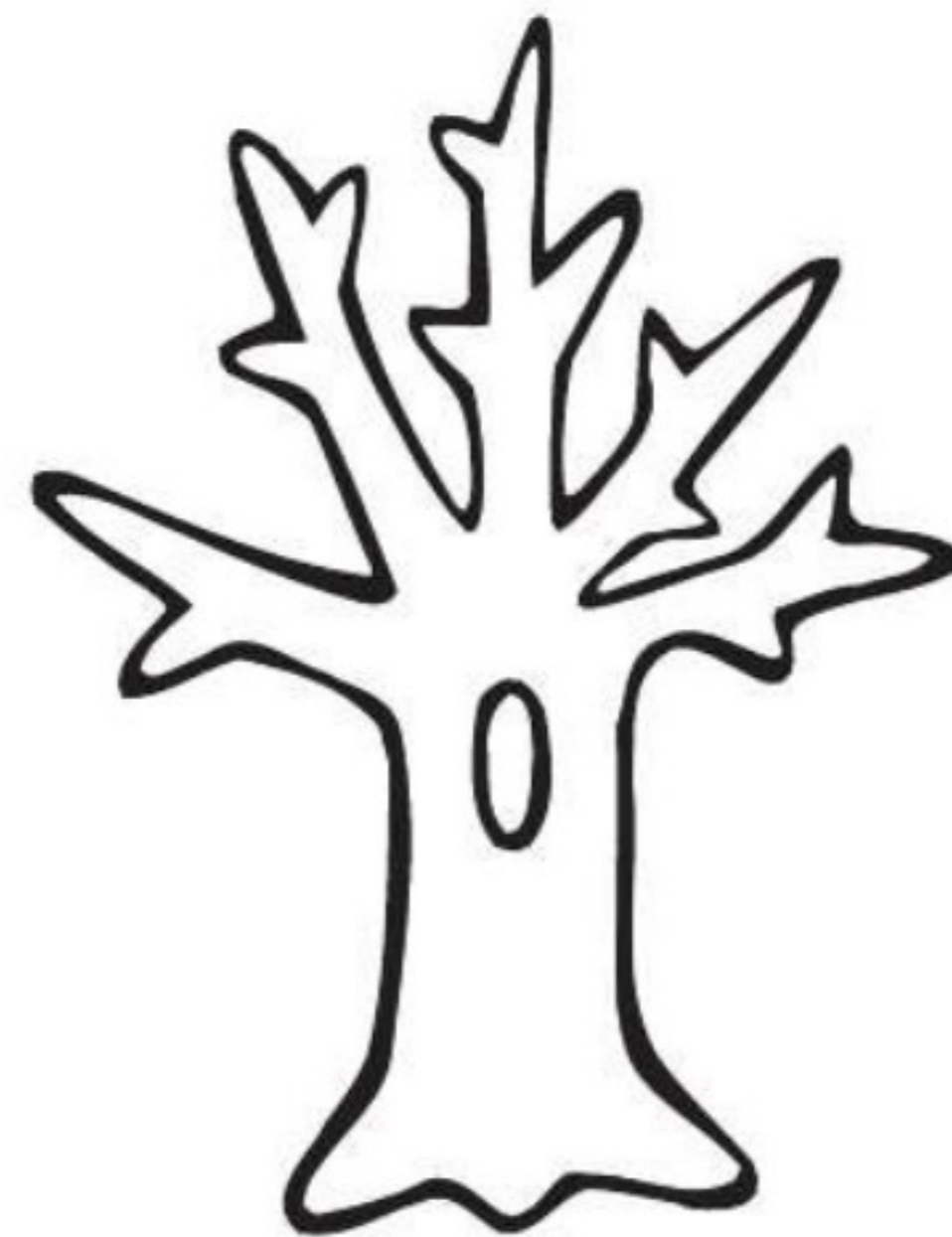

**SPRING**





# Critical Thinking

**Directions:** Color  and cut  apart the cards below.

Ask your child to match each mother to its baby.

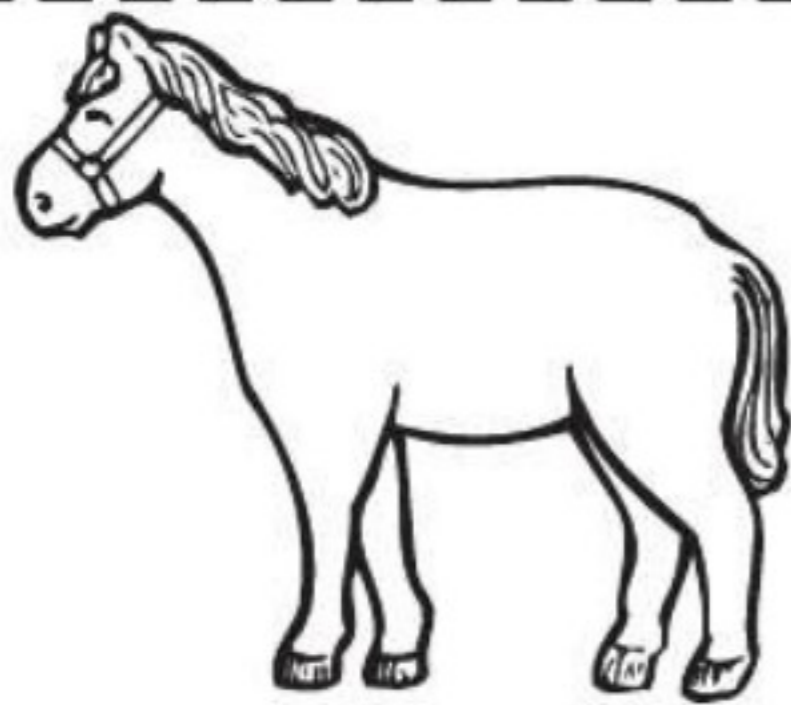

**horse**

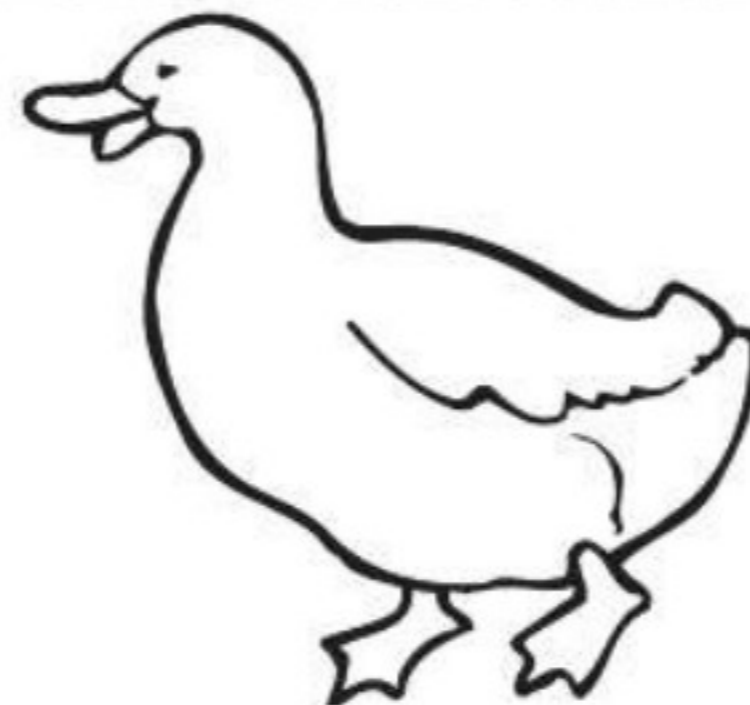

**duck**

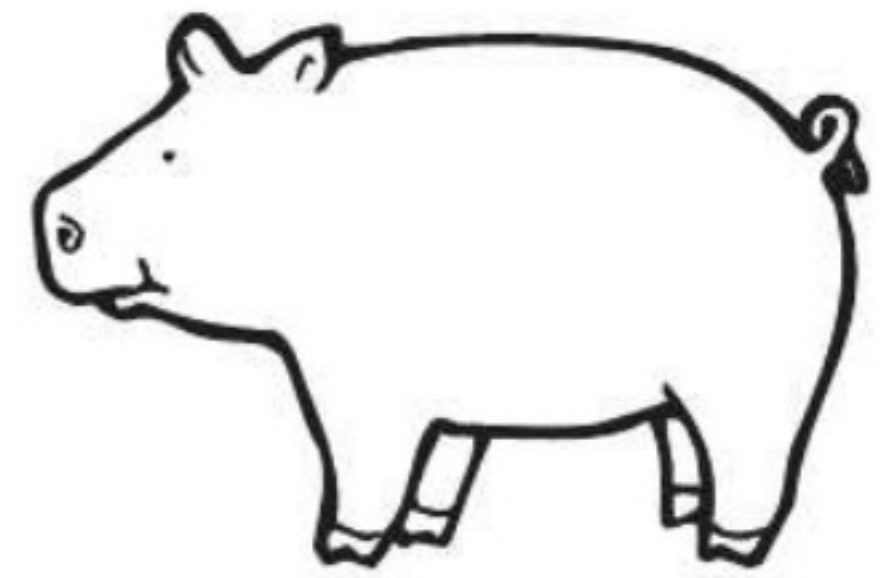

**pig**

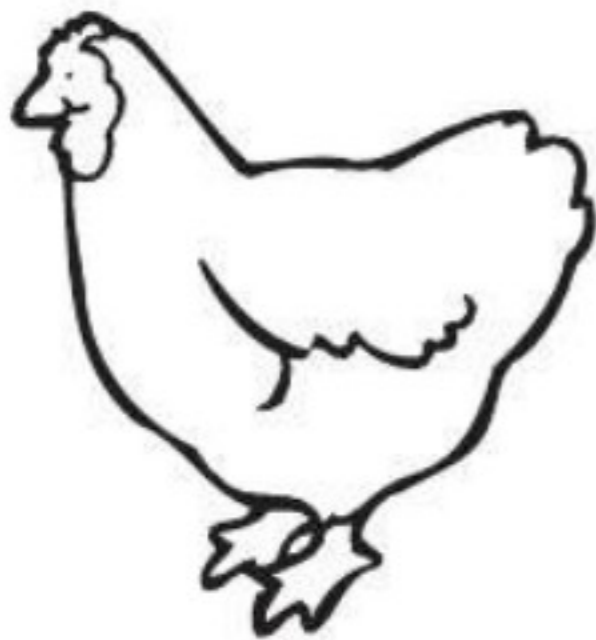

**hen**

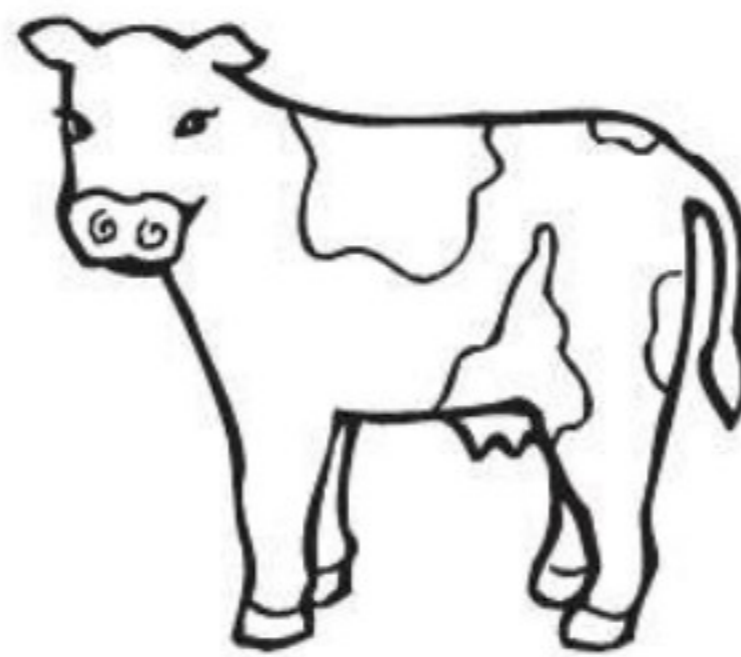

**cow**

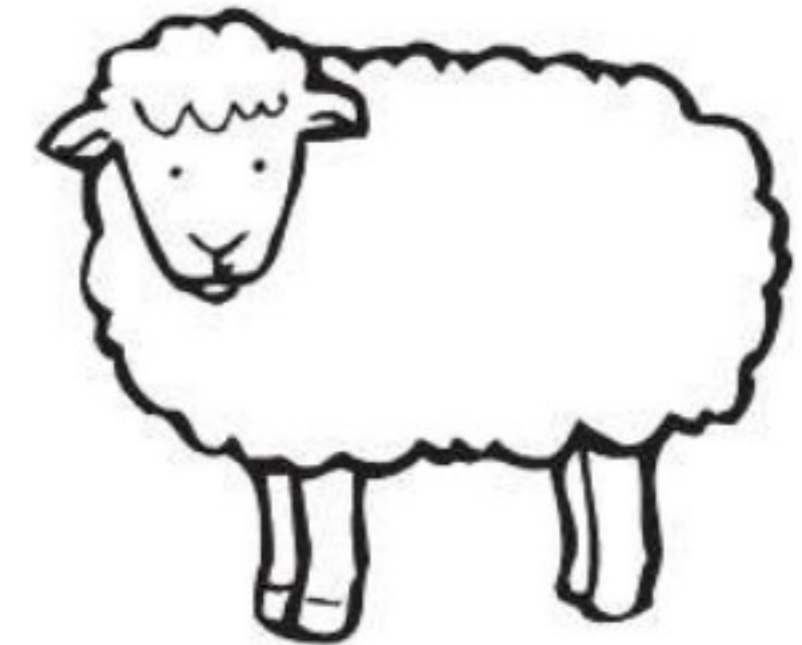

**sheep**

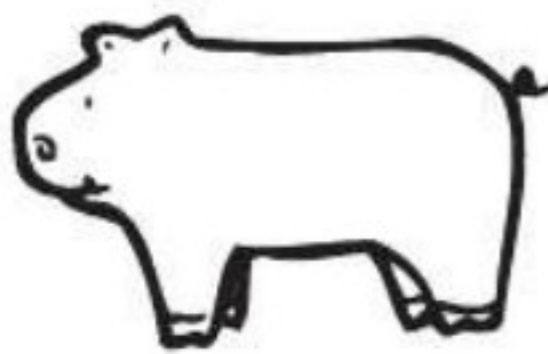

**piglet**



**chick**

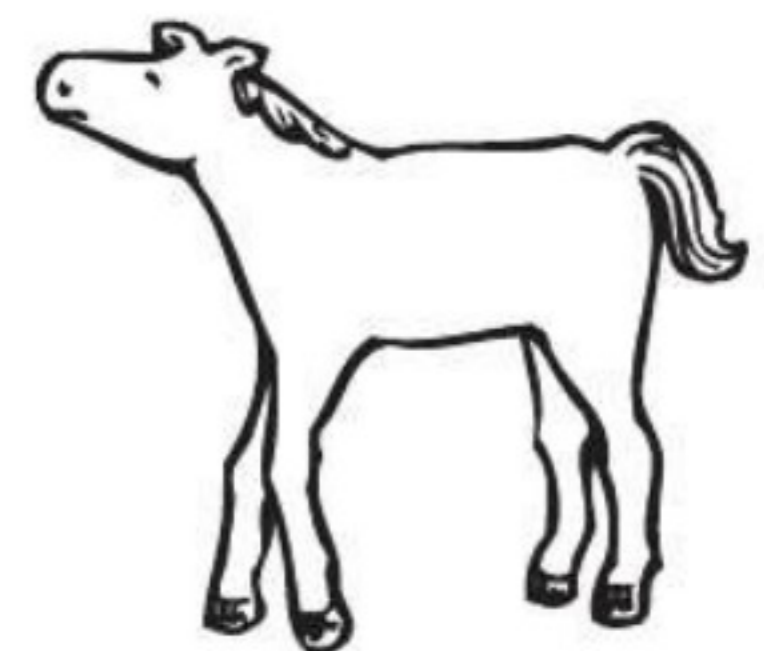

**foal**

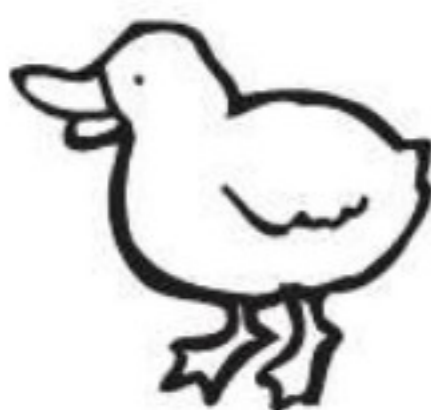

**duckling**

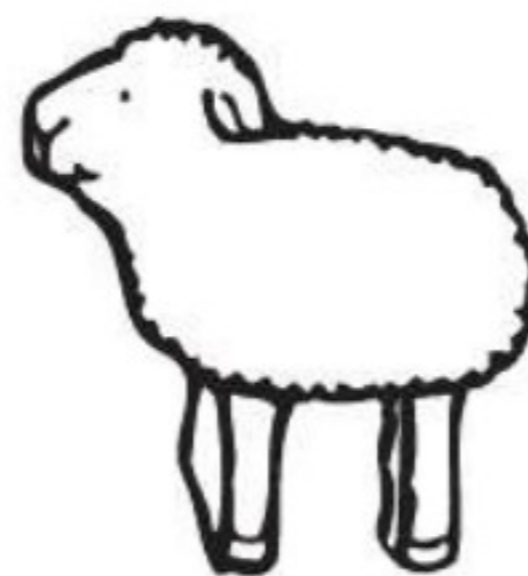

**lamb**

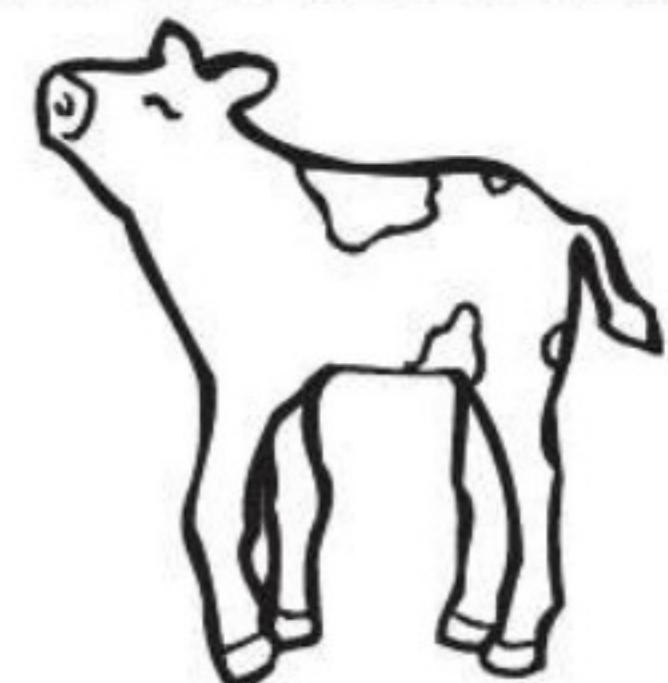

**calf**





# I'm Hungry!

**Directions:** Draw  a line to match each animal to the food it likes to eat.

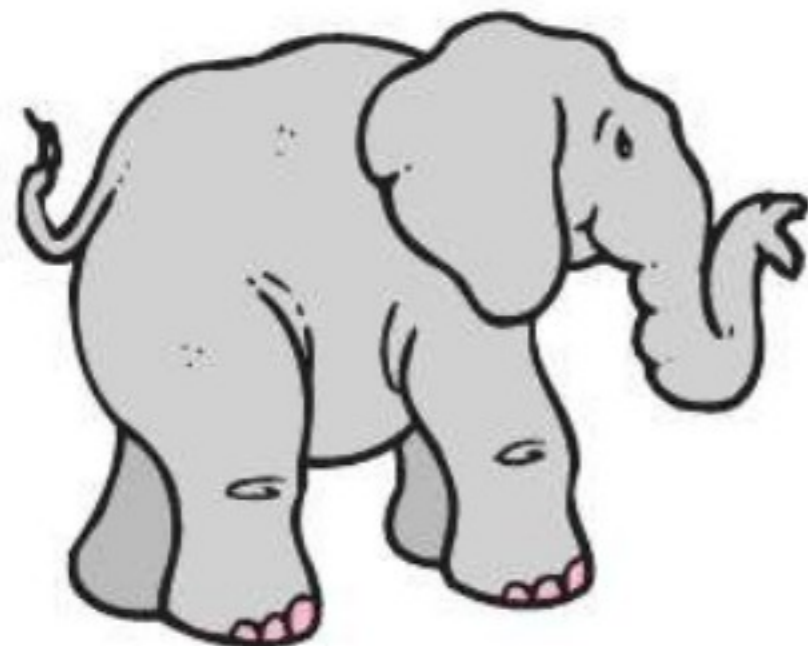
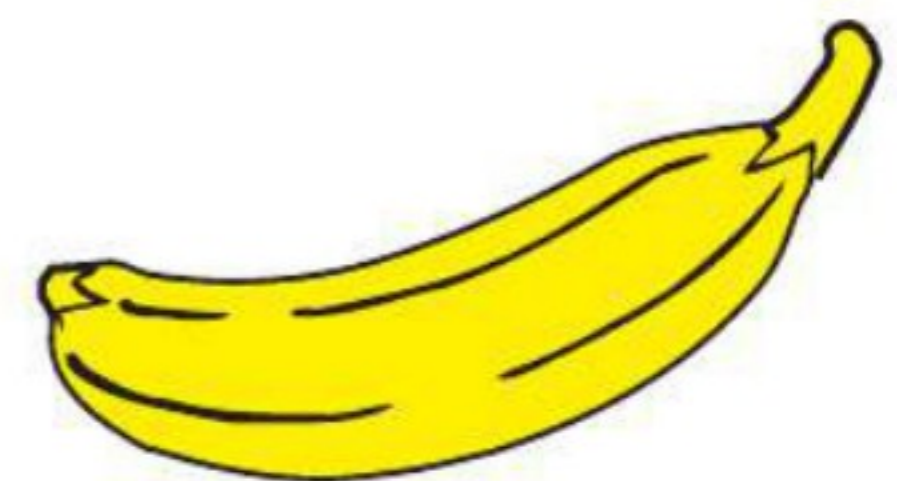
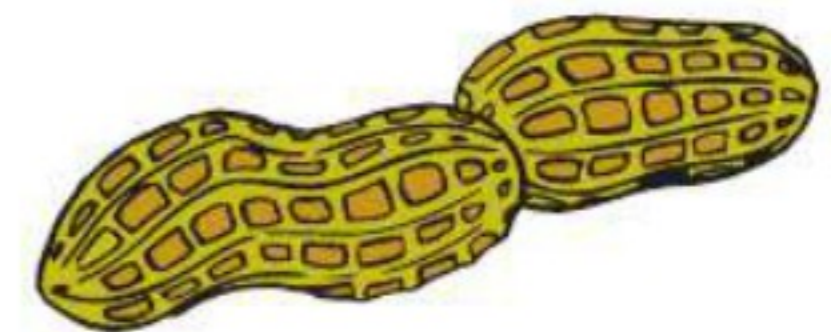
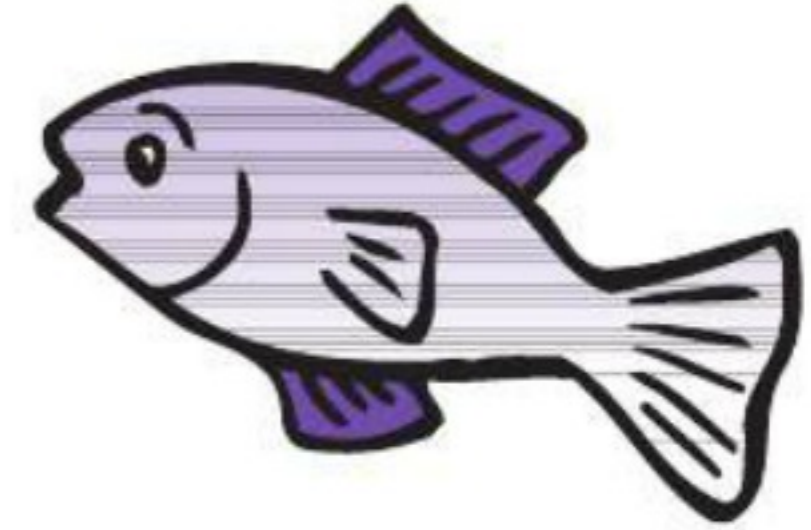



# Kindergarten Readiness Guide

Being “ready” for kindergarten means, quite simply, that your child is able to learn what will be taught in the kindergarten he or she will attend, and can function comfortably with teachers and other children in that setting.

Since learning builds upon learning, this means that your child needs to have acquired the skills, information, and attitudes that are necessary to do this, and to be able to be part of a group and get along with others.

When parents think about kindergarten readiness, they sometimes focus too much on academics. The skills that define readiness are far broader than knowing letters, numbers, and colors.

To be ready for kindergarten, your child needs to have a positive attitude toward starting school and some understanding of why he or she will be going there. He or she needs to be receptive to learning new things and making new friends.

The best way to learn what will be expected of your child is to contact the school your child will attend and speak to the teachers there. If a kindergarten readiness screening will be offered, take advantage of it.







There is no single quality or skill that enables children to perform well in school. Rather, it's a combination of qualities and skills that contributes to their academic success. Kindergarten readiness screening, which is generally offered in the early spring prior to the start of kindergarten, gives parents and kindergarten staff an inventory of each child's developmental qualities and abilities.



Kindergarten readiness screening provides readiness feedback for parents who want their child to have the best possible start when entering kindergarten. It helps the kindergarten staff get an idea of the developmental level of each child before the year actually begins, so appropriate planning and instruction is in place for the incoming class. At the same time, it provides each child with a low-key, non-threatening opportunity to sample some fun, play-based activities in a comfortable school atmosphere.

Typically, kindergarten staff and other school aides set up several different activity stations in a room for your child to visit. Depending on the size of the staff and the room, the activities may accommodate one child at a time or small groups.



While children participate in the screening activities, parents may be invited to observe silently at a distance so as not to distract or interrupt them. Some screening programs invite parents to complete a Parent Questionnaire at the same time that the screening occurs.

Examples of typical parent questionnaires and activity stations are outlined on the following pages.



## Parent Questionnaire

Many kindergarten screening programs set up an opportunity for parents to provide their child's medical history and developmental background.

Typical questions include:

- complications or special circumstances regarding child's birth, such as a premature delivery
- hospital stays, surgeries, special tests performed
- serious illnesses or injuries
- child's current medications or treatments
- child's current immunization record
- child's early temperament, such as quiet, colicky, carefree, overactive
- child's style of expressing emotion, such as reserved, talkative, temper tantrums
- child's age when developmental milestones, such as speaking first words, were reached
- family information, such as number, age, and sex of child's siblings



## Speech, Language, and Hearing Development

It is very important for a child entering kindergarten to be able to understand his or her teachers in order to learn and to know what to do. Likewise, it's very important for a child to be able to speak clearly and to be understood by others in order to express his or her needs. In addition to identifying any speech and hearing disorders, most kindergarten screenings also assess the following language developments:

- speak clearly enough so that people other than child's own family and friends can understand easily
- repeat a simple sentence
- respond to simple directions, such as where to sit, put a book, or throw a ball
- talk in complete sentences of five to six words
- produce early-developing initial and final consonant sounds—n, m, p, b, h, k, g, f, w, y, t, d
- begin to produce later-developing sounds—s, z, l, r, sh, ch
- look at pictures and then tell stories about them



## Self-Help and Social Skills

In kindergarten, young children will need to work well in large groups, get along with new adults and other children, and share the teacher's attention with other youngsters. Classroom routines will also be different from children's at-home routines. Consequently, children need to:

- be able to be away from their parents or people they know for a few hours without being upset
- be willing and happy to be going to school
- be able to listen attentively when spoken to for three or more minutes
- be willing to try new tasks, and to try them again if they don't succeed the first time
- be able to follow a two- or three-step direction, such as "Close the door and hang up your coat."
- be able to play with other children without having a lot of fights
- be able to do some self-help things for themselves, such as take off and put on jackets and sweaters

## Large-Motor Development

Before going to school, children need to have good control over their movements. They need to be able to sit, stand, walk, climb stairs, and run without bumping into things, hurting themselves, or breaking things. In school, they'll be part of a group that is doing the following things:

- walk down steps, placing one foot on each step
- walk forward on a line, putting one foot after the other
- walk backwards for six or seven steps without turning to look behind
- stand on one leg at a time for 10 seconds
- stand on two feet, hands on hips, and bend body forward, backward, and sideways
- hop with two feet together
- hop on one foot a few times without falling
- jump using both feet at the same time
- kick a ball
- pump himself or herself on a swing





- balance on one foot for a few seconds
- run without falling frequently
- bounce a ball five consecutive times
- bounce a ball to another person 4 or 5 feet away
- throw and catch a ball using both hands
- carry something on top of something else, such as a juice box on a plate
- touch parts of his or her body with both hands, such as shoulders, neck, knees, toes, hips, chest
- dance while moving forward, backward, sideways left, and sideways right
- skip
- clap hands to music



### Small-Motor Development

In school, children need to use their hands and fingers to open and close things and to use things without dropping, breaking, or spilling them. They need to be able to hold pencils and crayons correctly so they can learn to write and do math. Kindergarten screening of the following tasks allows for assessment of small-motor skill development:

- hold a pencil or marker comfortably using thumb and fingers
- open a door using a doorknob
- use crayons without breaking them
- use round-tipped scissors effectively
- color and stay within lines reasonably well
- copy a square on paper
- draw a reasonably good circle on paper
- put together a 9-piece puzzle
- print first name using capital and lowercase letters
- use paste or glue without too much mess
- string wooden beads together
- hammer pegs on a board
- use a spoon without spilling
- get a drink of water without a mess
- turn pages of a book without tearing pages



## General Knowledge

Before children start school, there are some things they need to know so they will understand what is going on around them and what teachers and other people are talking about.

- know their own name, age, sex, address or street name, and telephone number
- know mother's and father's first and last names
- know names and ages of brothers and sisters
- name several parts of their own body, such as nose, mouth, hair, eyes, throat, chest, elbow, ankle
- know some things that are around their home, such as bed, door, steps, table
- know some words for when things happen in time, such as now, later, soon, never, before bedtime
- know words for how things compare, such as same, different, more, less
- know something about the places around them and what happens there, such as store, gas station, hospital, doctor's office
- know appropriate words to use to ask to go to the bathroom





## Academic Readiness Components

- understands basic concepts
  - positions, such as top, middle, bottom, left, right
  - locations, such as down, up, above, below, across, over
  - quantity, such as less, more, many, few, heavy, light, small, large
  - recognizes feelings, such as happiness, sadness, anger, fear
- demonstrates memory perception
  - knows which object was removed from an earlier group
  - matches objects to pictures
- demonstrates strategies for understanding concepts
  - understands simple cause and effect, such as touching something hot can cause a burn
  - can sort objects into categories, such as vegetables are food
  - can identify and name the capital letters of the alphabet
  - can identify concepts about print, such as recognizing the cover of a book and understanding that words read from left to right
  - understands the difference between letters and numerals
  - can briefly tell a story he or she has just heard
  - can describe what he or she is playing
  - can describe his or her drawing
  - knows some nursery rhymes
  - can state choices about clothing
  - can follow directions for simple games, such as Red Light! Green Light!
  - asks questions beginning with *why* or *how*
  - recognizes his or her own name in print
  - makes actual letters, such as those in his or her name
  - attempts to print other letters and some words





## Nurture Development

As you help your child get ready for kindergarten, remember that your goal is to nurture excitement for learning. Every skill does not need to be mastered by your child. In fact, complete mastery of every skill by a child is a rarity.

Skills are learned best if they are not turned into lessons. Introduce skills naturally in small doses, reinforcing from time to time through casual conversations and play.

Here are a few tips as you help your child prepare for kindergarten:

- Allow your child to learn by doing.
- Read, read, read, read to your child!
- Envelop your child in language—describe, explain, discover, and communicate at every opportunity.
- Ask your child to describe and explain things of interest.
- Praise your child for asking questions. Asking a question shows a high level of thinking and reasoning.
- Be patient as your child is learning. Don't try too hard or too early. Repetition and practice are helpful when the activity is fun.



# Answer Key

**Color Red Things**

Directions: Color Kitty's red.  
Color the pictures to match the red.

Note to Parents: Have a scavenger hunt in your home to gather red items with your child.

4

**Trace and Write Red**

Directions: Trace the word "red" in the second box below. Then, in the third box, write "red" on your own.

red red

red

Directions: Which three could be red? Color with red.

Note to Parents: Ask your child to name things that are red.

5

**Color Yellow Things**

Directions: Color Dilly's yellow.  
Color the pictures to match the yellow.

Note to Parents: Have a scavenger hunt in your home to gather yellow items with your child.

6

**Trace and Write Yellow**

Directions: Trace the word "yellow" in the second box below. Then, in the third box, write "yellow" on your own.

yellow yellow

yellow

Directions: Which three could be yellow? Color with yellow.

Note to Parents: Ask your child to name things that are yellow.

7

**Color Blue Things**

Directions: Color Teddy's blue.  
Color the pictures to match the blue.

Note to Parents: Have a scavenger hunt in your home to gather blue items with your child.

8

**Trace and Write Blue**

Directions: Trace the word "blue" in the second box below. Then, in the third box, write "blue" on your own.

blue blue

blue

Directions: Which three could be blue? Color with blue.

Note to Parents: Ask your child to name things that are blue.

9





# Answer Key

**Color Brown Things**

Directions: Color Kangaroo's brown.  
Color the pictures to match the .

**Note to Parents:** Have a scavenger hunt in your home to gather brown items with your child.

10

**Trace and Write Brown**

Directions: Trace the word "brown" in the second box below.  
Then, in the third box, write "brown" on your own.

brown brown

brown

Directions: Which three could be brown? Color with brown.

**Note to Parents:** Ask your child to name things that are brown.

11

**Color Green Things**

Directions: Color Rocky's green.  
Color the pictures to match the .

**Note to Parents:** Have a scavenger hunt in your home to gather green items with your child.

12

**Trace and Write Green**

Directions: Trace the word "green" in the second box below.  
Then, in the third box, write "green" on your own.

green green

green

Directions: Which three could be green? Color with green.

**Note to Parents:** Ask your child to name things that are green.

13

**Color Purple Things**

Directions: Color Pelly's purple.  
Color the pictures to match the .

**Note to Parents:** Have a scavenger hunt in your home to gather purple items with your child.

14

**Trace and Write Purple**

Directions: Trace the word "purple" in the second box below.  
Then, in the third box, write "purple" on your own.

purple purple

purple

Directions: Which three could be purple? Color with purple.

**Note to Parents:** Ask your child to name things that are purple.

15



# Answer Key

**Color Orange Things**

Directions: Color the Puppy's orange.  
Color the pictures to match the .

Note to Parents: Have a scavenger hunt in your home and gather orange items with your child.

16

**Trace and Write Orange**

Directions: Trace the word "orange" in the second box below. Then, in the third box, write "orange" on your own.

orange orange

orange

Directions: Which three could be orange? Color with orange.

Note to Parents: Ask your child to name things that are orange.

17

**Color Black Things**

Directions: Color Penguin's black.  
Color the pictures to match the .

Note to Parents: Have a scavenger hunt in your home and gather black items with your child.

18

**Trace and Write Black**

Directions: Trace the word "black" in the second box below. Then, in the third box, write "black" on your own.

black black

black

Directions: Which three could be black? Color with black.

Note to Parents: Ask your child to name things that are black.

19

**Color Review**

Directions: Color each picture the correct color.

20

**Color Review**

Directions: Color each . Color the tool.

Directions: Use each color from the to color the pictures. Color the to match.

21



# Answer Key

**Trace and Write Circles**

Directions: This is a circle: ○ Trace and color each circle the correct color.

Directions: Trace the word "circle" in the second box below. Then, in the third box, write "circle" on your own.

circle circle

circle

22

**Color and Draw Circles**

Directions: Circles can be different sizes. Trace the circles. Find all the circles and color them.

Directions: Now, draw your own circles.

Circles will vary.

23

**Trace and Write Squares**

Directions: This is a square: □ Trace and color each square the correct color.

Directions: Trace the word "square" in the second box below. Then, in the third box, write "square" on your own.

square square

square

24

**Color Squares**

Directions: Color the ten things in the picture which are made with squares.

25

**Trace and Write Triangles**

Directions: This is a triangle: △ Trace and color each triangle the correct color.

Directions: Trace the word "triangle" in the second box below. Then, in the third box, write "triangle" on your own.

triangle triangle

triangle

26

**Color and Circle Triangles**

Directions: Color each triangle to find the path home.

Directions: Circle each picture made with a triangle.

27



# Answer Key

**Trace and Write Rectangles**

Directions: This is a rectangle. Trace and color each rectangle the correct color.

Directions: Trace the word "rectangle" in the second box below. Then, in the third box, write "rectangle" on your own.

rectangle rectangle

rectangle

28

**Color and Cut Out Rectangles**

Directions: Color, cut, and glue each to complete the picture.

29

**Shape Review**

Directions: Color each square blue. Color each circle green. Color each triangle brown. Then, finish the picture with your favorite colors!

31

**Big**

Directions: Some things are big. Some things are small. Which one is big? Color the one that is big in each row.

32

**Small**

Directions: Which one is small? Color the one that is small in each row.

33

**Long**

Directions: Some things are long. Some things are short. Color the things that are long in each row.

34



# Answer Key

**Short**

**Directions:** Which one is short? Color the one that is short in each row.

35

**Tall**

**Directions:** Some things are tall. Some things are short. Look at the pictures in each box. Color the people who are tall.

36

**Short**

**Directions:** Look at the pictures in each box. Color the objects that are short in each box.

37

**Full and Empty**

**Directions:** Circle the full container. Draw an X on the empty container.

38

**More Full and Empty**

**Directions:** Circle the full container. Draw an X on the empty container.

39

**Night and Day**

**Directions:** Circle the things you usually do at night.

**Directions:** Draw and color a picture of something you do only in the day.

Pictures will vary.

40



# ANSWER KEY

## Answer Key

**Match Opposites**

Directions: Draw a line to match each picture with its opposite.

full out  
in short  
tall empty

41

**Draw Opposites**

Directions: Draw a picture of the opposite.

day

**Pictures will vary.**

night

42

**Draw Opposites**

Directions: Draw a picture of the opposite.

sad

**Pictures will vary.**

happy

43

**Hot and Cold**

Miriam's mom just made breakfast. What things are hot on the table? What things are cold?

Directions: Circle all the hot things with a red crayon.  
Circle all the cold things with a blue crayon.

What would you eat for breakfast if you were Miriam?

44

**Fast and Slow**

Look at the pictures below.

Directions: Circle all the things that go fast.  
Draw an X on each thing that goes slow.

45

**Match Opposites**

Directions: Draw a line to match each picture with its opposite.

left sad  
above right  
happy below

46



# Answer Key

**More Opposites**

Look at the pictures below.  
**Directions:** Draw a line to match each picture to its opposite.

47

**In the Tree**

**Directions:** Draw lines to connect the tree to the things you might find in a tree.

**Note to Parents:** Talk with your child about the choices he or she made. Check out the trees in your neighborhood to see what you can find.

48

**We Go Together**

**Directions:** Draw lines to match the things that go together.

**Note to Parents:** Talk with your child about the choices he or she made.

49

**Baby Animals**

**Directions:** Draw a line to match each baby animal to its parent. Color the pictures.

50

**What Belongs?**

**Directions:** Draw a red X on the animals that do not belong in the picture. Color the animals that do belong.

**Note to Parents:** Talk with your child about his or her selections. Sort toy animals according to where they live: forest, jungle, ocean, desert, etc.

51

**Part of a Group**

**Directions:** Pick 3 pictures that go together in each group. Draw an X on the picture that does not belong in the group.

52



# Answer Key

**Three Things**

Directions: Circle your answers below.

Which 3 things are on your face?

Which 3 things would you need to sleep?

Which 3 animals like to go in the water?

Which 3 things would you wear if you were cold?

53

**We Are the Same**

Directions: Circle each picture that is the same as the first picture in the row.

54

**Color the Same Things**

Directions: Color the pictures in each row that are the same.

55

**Which One Is Different?**

Directions: Circle the puzzle piece in each row that is different.

56

**Different Things**

Directions: Circle the picture in each row that is different.

57

**Same Words**

Directions: Look at the words below. Circle the two words in each row that are the same. The first one shows you what to do.

58





# Answer Key

**More of the Same**

Directions: Look at the words below. Circle the word that is the same as the first word in the row. The first one shows you what to do.

bug	bug	mug
bat	bat	mat
pin	tin	pin
jam	ham	jam

59

**Same Objects**

Directions: Circle the mug to show it is the same as the first mug. Circle the object that is the same in each row.

60

**Pam's Purple Shoes**

Pam loves to wear purple shoes. All her shoes are purple!

Directions: Draw a line connecting each pair of matching shoes.

Which pair of shoes should Pam wear to the beach? Which pair of shoes should she wear with her pajamas?

Circle your favorite pair of shoes above.

61

**Cats and Dogs**

Look at the cat and dog below. Can you name two ways that they are the same? Can you name two ways that they are different?

Answers will vary.

What would you name the cat? What would you name the dog? Which do you like better, the cat or the dog?

Directions: Circle the one you like the most.

62

**Mama Bear**

A baby bear is called a cub. Each cub looks like its mother.

Directions: Draw a line to match each cub to its mama bear.

Did you know that bears hibernate in the winter? What color are the bears that are sleeping? What is a baby bear called? Are you a cub?

63

**Help Get Us Home**

Help each animal get home!

Directions: Use your finger to trace a path from left to right. Then, draw a line with a pencil or a crayon to connect each animal with its home.

64



# Answer Key

**Follow, Follow**

**Directions:** Follow the animals with your finger as they move across the page. Then, draw a line with a pencil or a crayon to trace each path.

65

**Where Is My Home?**

**Directions:** Draw a line from each animal to its home.

**Note to Parents:** These activities help with one-to-one correspondence and tracking left to right, which is a pre-reading skill.

66

**One to One**

**Directions:** Draw lines to help the ants get back to the picnic baskets!

67

**Let's Play!**

**Directions:** Draw a line from each picture on the left to a place to play on the right. The first one is done for you.

68

**Help the Bunnies**

**Directions:** Draw lines to help the bunnies get their carrots!

69

**Matching Tops to Bottoms**

**Directions:** Look at the pictures in each box. Starting at the top and going to the bottom, draw a line to match each thing at the top to the thing at the bottom. Color the pictures.

**Note to Parents:** Encouraging your child to start at the top when making vertical lines will help your child develop good handwriting habits for learning to print letters.

70



# Answer Key

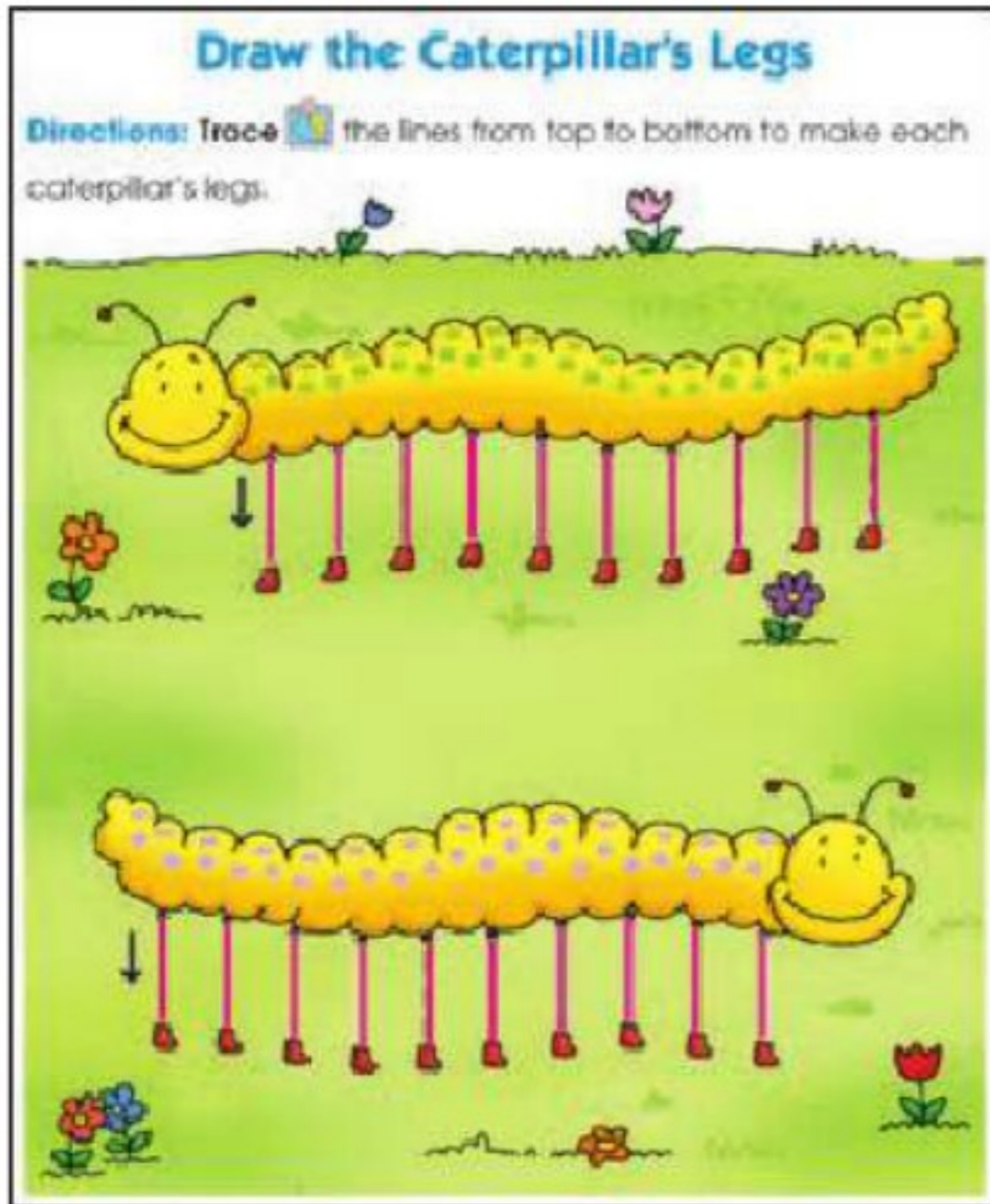

71

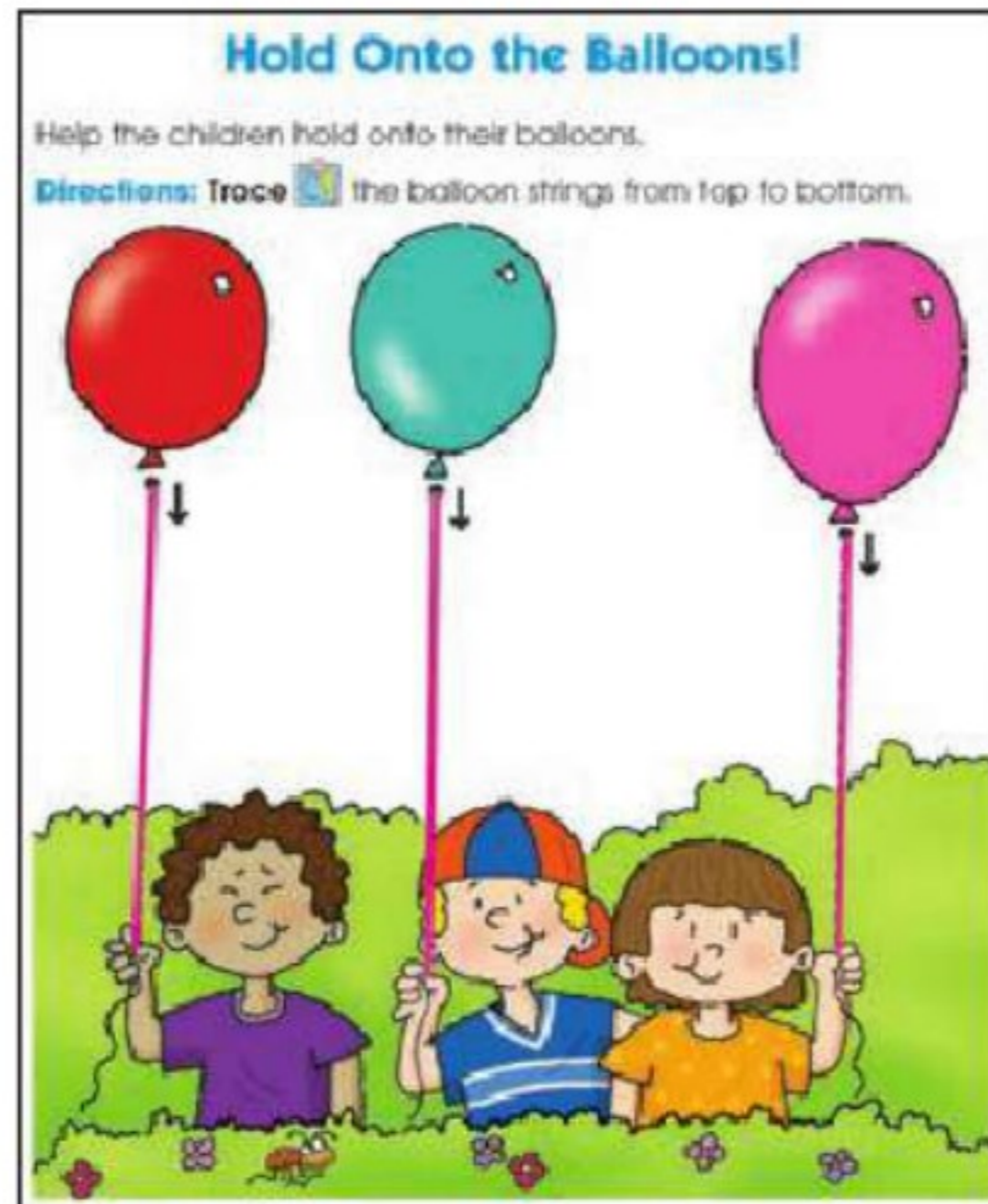

72

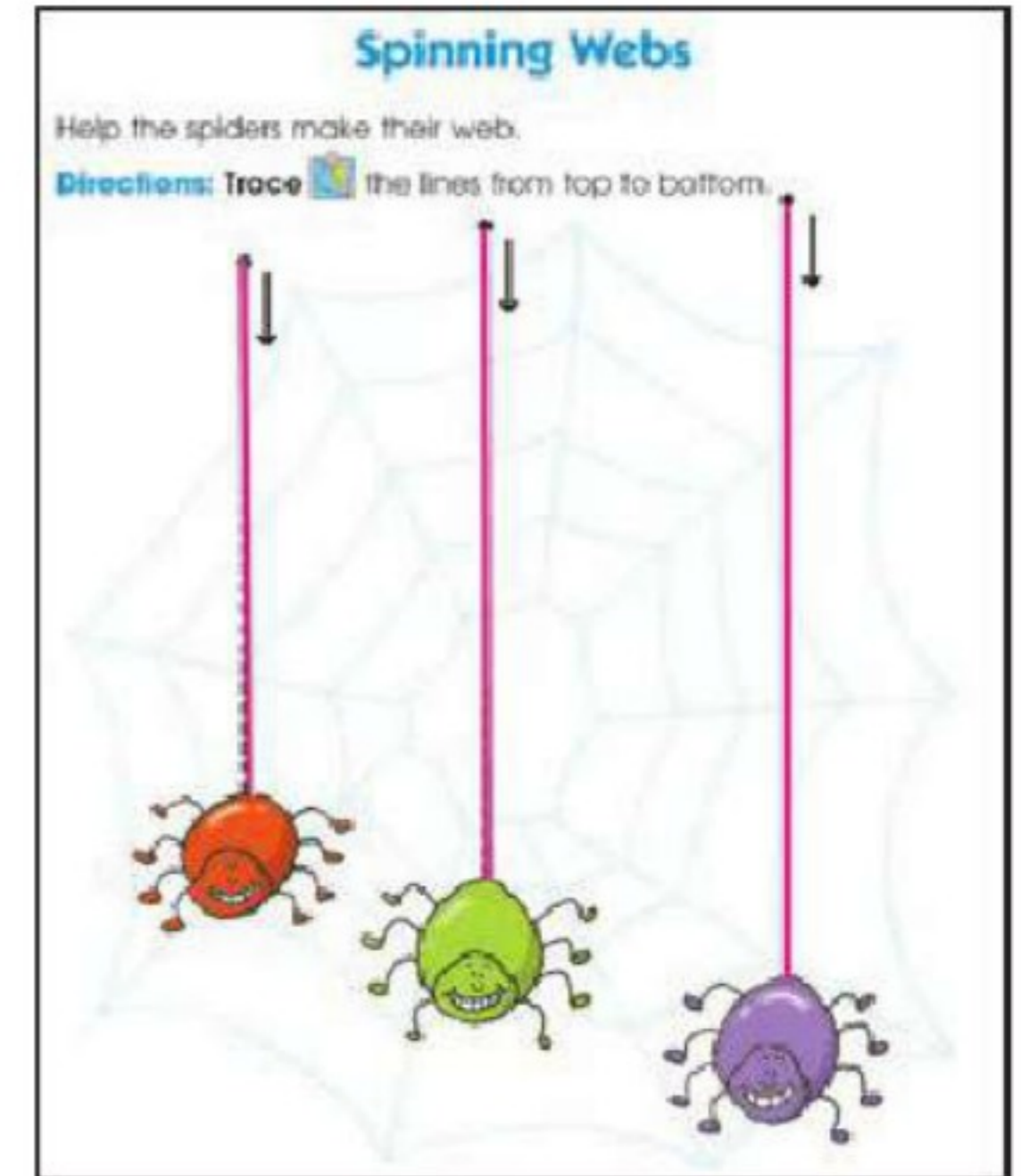

73

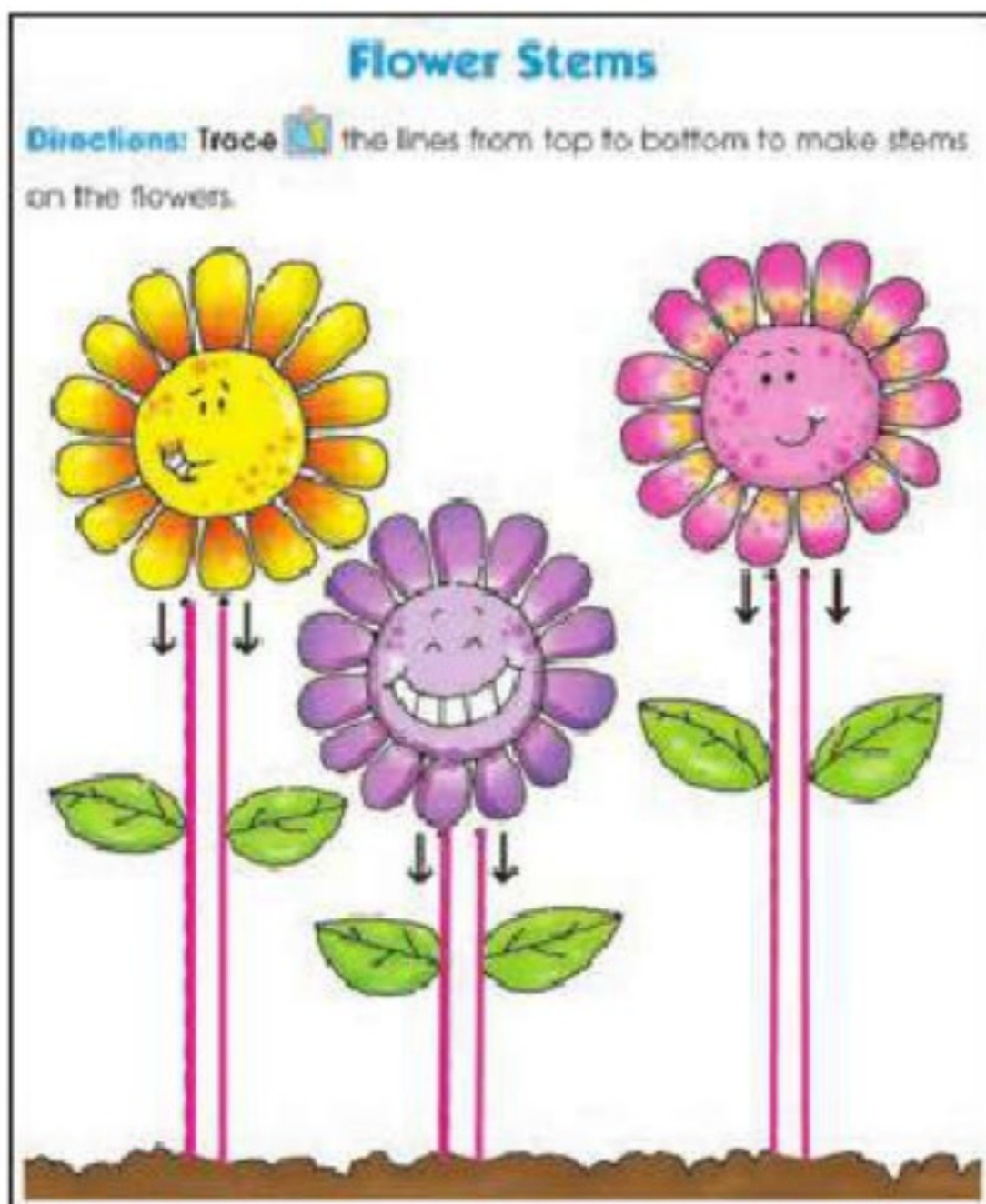

74

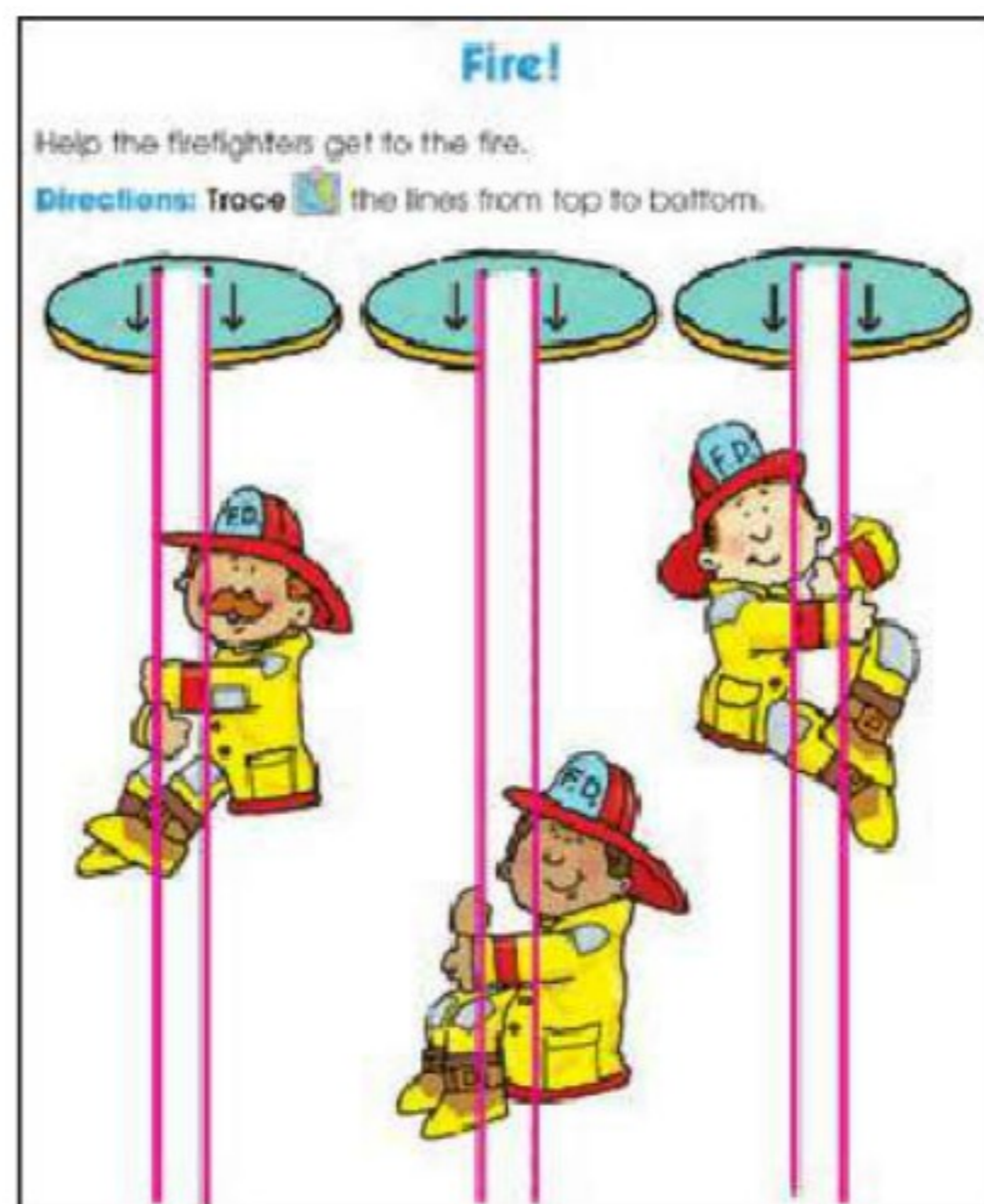

75

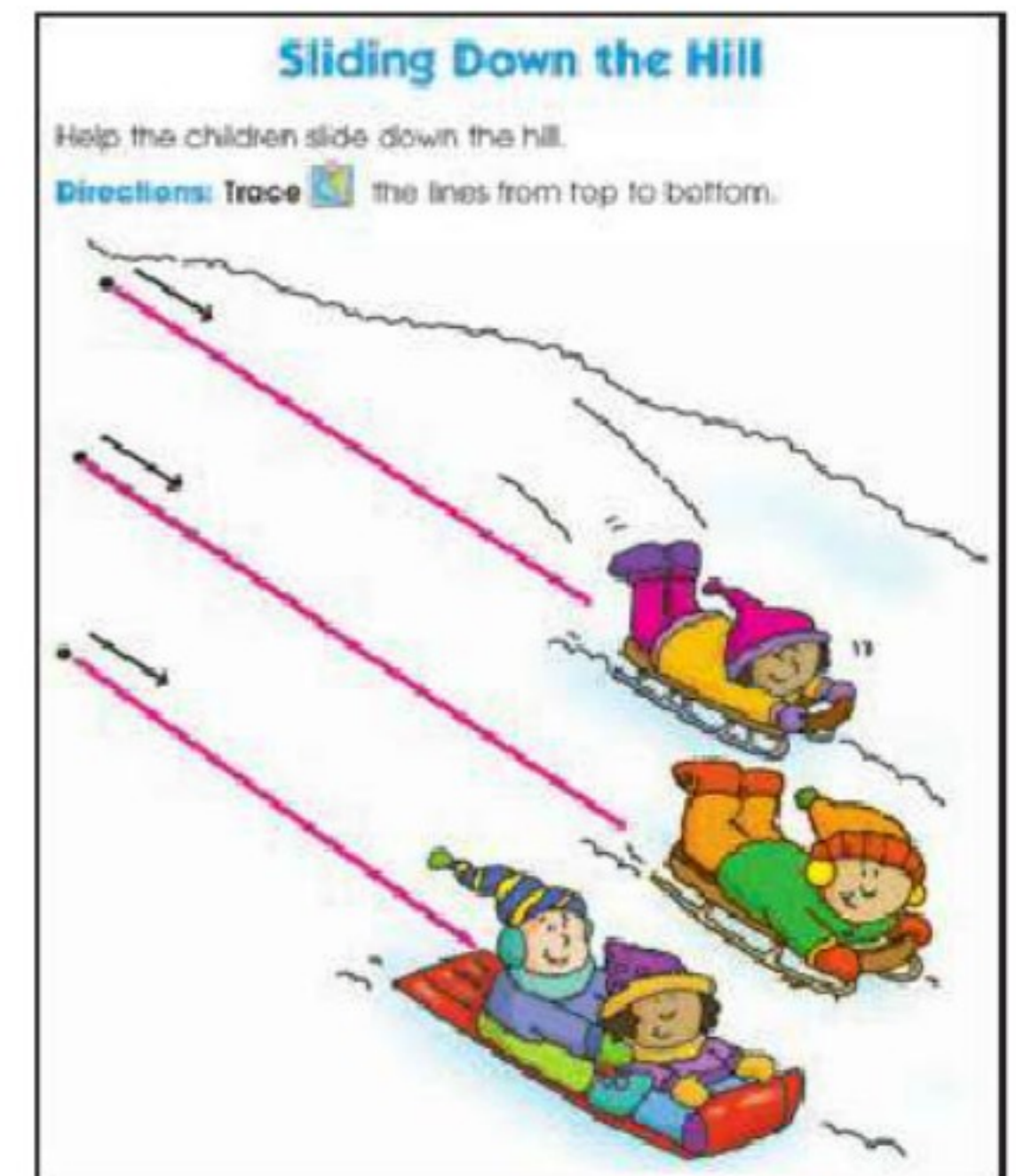

76



# Answer Key

**Slanted Lines**

Directions: Start at the top dots. Trace the dotted lines.

77

**Curved Lines**

Directions: Trace each ball's bounces from left to right.

Now, draw this ball's bounces on your own.

78

**More Curved Lines**

Directions: Start at the dots. Trace the dotted lines.

79

**Forward Circles**

Directions: Follow the arrows to trace the circles on each ice-cream cone.

80

**More Forward Circles**

Directions: Follow the arrows to trace each circle on the sun and the flowers.

81

**Backward Circles**

Directions: Start at the dots. Trace the dotted lines.

82



# Answer Key

**More Backward Circles**

Directions: Follow the arrows to trace each circle on the lollipops.

83

**Letter Aa**

Directions: Trace and write the letter Aa.

UPPERCASE  
A A A A A A A A

lowercase  
a a a a a a a a

Directions: These pictures begin with the letter Aa.  
Color the pictures.

84

**Letter Aa**

You can help the ant find the ant.

Directions: Draw a line to follow the letters A and a.  
Color the picture.

85

**Letter Aa**

Directions: Circle the A or a in these words:  
Apple, alligator, angel, Amy, at, Andy

The letter Aa can have more than one sound.

Directions: Color the pictures that start with the sound of Aa

86

**Letter Aa**

These words start with A or a.

Directions: Write a lowercase a on each line.  
Color the pictures.

A is for a pple.

A is for a ngel.

A is for a nt.

87

**Letter Bb**

Directions: Trace and write the letter Bb.

UPPERCASE  
B B B B B B B B

lowercase  
b b b b b b b b

Directions: These pictures begin with the letter Bb.  
Color the pictures.

88



# Answer Key

**Letter Bb**

Find each hidden B and b.

Directions: Draw a blue circle around each B and a green circle around each b.

89

**Letter Bb**

Directions: Circle the B or b in these words:

Bill    bawn    Bonnie  
boy    bb    balloon

Directions: Color the pictures that start with the sound of Bb.

90

**Letter Bb**

These words start with B or b.

Directions: Write a lowercase b on each line.

Color the pictures.

B is for buttons.

B is for bat.

B is for bug.

91

**Letter Cc**

Directions: Trace and write the letter Cc.

UPPERCASE

lowercase

Directions: These pictures begin with the letter Cc.

Color the pictures.

92

**Letter Cc**

Find each C and c that the cat has made with the yarn.

Directions: Color each UPPERCASE C red. Color each lowercase c yellow.

93

**Letter Cc**

Directions: Circle the C or c in these words:

cat    Casey    can  
cow    cam    coral

Directions: Color the pictures that start with the sound of Cc.

94



# Answer Key

**Letter Cc**

Help Calico Cat catch what she is chasing.

**Directions:** Circle the pictures that begin with the sound of Cc. Color the pictures.

95

**Letter Dd**

**Directions:** Trace and write the letter Dd.

UPPERCASE  
D D D D D D D D

lowercase  
d d d d d d d d

**Directions:** These pictures begin with the letter Dd.  
Color the pictures.

96

**Letter Dd**

**Directions:** Color the spaces with the letters D or d purple.  
Color the spaces with the other letters orange.  
What did you find?

Color the doll, too!

97

**Letter Dd**

**Directions:** Circle the D or d in these words:  
Dill, Darcy, Disk, Door, David, Dog

**Directions:** Color the pictures that start with the sound of Dd.

98

**Letter Dd**

These words start with D or d.

**Directions:** Write a lowercase d on each line.  
Color the pictures.

D is for d og.

D is for d rum.

D is for d uck.

99

**Letter Ee**

**Directions:** Trace and write the letter Ee.

UPPERCASE  
E E E E E E E E

lowercase  
e e e e e e e e

**Directions:** These pictures begin with the letter Ee.  
Color the pictures.

100



# Answer Key

**Letter Ee**

Help the elephant find its way to the circus tent.

**Directions:** Color the **E**s with **e** brown. Color the other **e**s green. Color the rest of the picture.

101

**Letter Ee**

**Directions:** Circle the **E** or **e** in these words:

ear Elizabeth egg  
earth Eric er

The letter **Ee** can have more than one sound.

**Directions:** Color the pictures that start with the sound of **Ee**.

102

**Letter Ee**

These words start with **E** or **e**.

**Directions:** Write a lowercase **e** on each line. Color the pictures.

E is for **e**nvelope.

E is for **e**ggs.

E is for **e**lephant.

103

**Letter Ff**

**Directions:** Trace and write the letter **Ff**.

UPPERCASE

lowercase

**Directions:** These pictures begin with the letter **Ff**. Color the pictures.

104

**Letter Ff**

Help the firefighter find each **F** and **f**.

**Directions:** Color a blue **f** of water around each **F**. Color a green **f** of water around each **f**. Color the picture.

105

**Letter Ff**

**Directions:** Circle the **F** or **f** in these words:

fire Frye fork  
fied farm fish

**Directions:** Color the pictures that start with the sound of **Ff**.

106





# Answer Key

**Letter Ff**

Directions: Color each picture on the fence that begins with the sound of ff.

107

**Letter Gg**

Directions: Trace and write the letter Gg.

UPPERCASE

lowercase

Directions: These pictures begin with the letter Gg. Color the pictures.

108

**Letter Gg**

Look at each sign in the garden.

Directions: Trace each G and g. Then, color each sign with G red and g blue.

How many?

I have  
 \_\_\_ Gs  
 \_\_\_ gs

109

**Letter Gg**

Directions: Circle the G or g in these words:

Goat Gregory Gate  
 Goat Gloria Gift

Directions: Color the pictures that start with the sound of Gg.

110

**Letter Gg**

Which cars need gas?

Directions: Draw a line from the gas pump to each car that has a driver that begins with G or g. Color the picture.

111

**Letter Hh**

Directions: Trace and write the letter Hh.

UPPERCASE

lowercase

Directions: These pictures begin with the letter Hh. Color the pictures.

112



# Answer Key

**Letter Hh**

**Directions:** Color the spaces with an UPPERCASE H red.

Color the spaces with a lowercase h purple. What did you find?

113

**Letter Hh**

**Directions:** Circle the H or h in these words:

Heather nose house  
Henry horse hand

**Directions:** Color the pictures that start with the sound of Hh.

114

**Letter Hh**

These words start with H or h.

**Directions:** Write a lowercase h on each line.

Color the pictures.

115

**Letter Ii**

**Directions:** Trace and write the letter Ii.

UPPERCASE

lowercase

**Directions:** These pictures begin with the letter Ii.

Color the pictures.

116

**Letter Ii**

Help read the 's smoke signals.

**Directions:** Color each I red. Color each i blue.

Color the rest of the picture!

117

**Letter Ii**

**Directions:** Circle the I or I in these words:

is ice cream igloo  
Ivan Icing Indian

The letter Ii can have more than one sound.

**Directions:** Color the pictures that start with the sound of Ii.

118



# Answer Key

**Letter Ii**

These words start with I or i.

**Directions:** Write a lowercase i on each line.  
Color the pictures.

I is for insects.

I is for igloo.

I is for inch.

119

**Letter Jj**

**Directions:** Trace and write the letter Jj.

UPPERCASE

lowercase

**Directions:** These pictures begin with the letter Jj.  
Color the pictures.

120

**Letter Jj**

Can you find each hidden J and j in the picture?

**Directions:** Color each J red. Color each j green.  
Then, color the rest of the picture!

121

**Letter Jj**

**Directions:** Circle the J or j in these words:

Jamal    Jump    Jennifer  
Jig    Jar    Jake

**Directions:** Color the pictures that start with the sound of Jj.

122

**Letter Jj**

Jake Jaguar likes jellybeans!

**Directions:** Draw a line from Jake Jaguar to each jellybean that has a picture that begins with the sound of Jj. Color the pictures with bright colors!

123

**Letter Kk**

**Directions:** Trace and write the letter Kk.

UPPERCASE

lowercase

**Directions:** These pictures begin with the letter Kk.  
Color the pictures.

124



# Answer Key

**Letter Kk**

Look at each letter on the kites.

**Directions:** Match the letters on the sections of the kites and color them the correct colors. Then, color the rest of the picture.

K = blue  
k = yellow

K = orange  
k = purple

K = green  
k = red

K = yellow  
k = red

125

**Letter Kk**

**Directions:** Circle the K or k in these words:

ky kjo kangaroo  
kim karate kally

**Directions:** Color the pictures that start with the sound of Kk.

126

**Letter Kk**

These words start with K or k.

**Directions:** Write a lowercase k on each line. Color the pictures.

K is for kangaroo.

K is for king.

K is for keg.

127

**Letter Ll**

**Directions:** Trace and write the letter Ll.

UPPERCASE

lowercase

**Directions:** These pictures begin with the letter Ll.

Color the pictures.

128

**Letter Ll**

It is fun to rake the fall leaves!

**Directions:** Color the leaves with L orange. Color the leaves with l red.

129

**Letter Ll**

**Directions:** Circle the L or l in these words:

letter Larry lion  
leah lamp ladder

**Directions:** Color the pictures that start with the sound of Ll.

130



# Answer Key

**Letter Ll**

Lucy lost her luggage! Help her find it.

**Directions:** Color the pictures on the luggage that begin with the sound of l. Then, color Lucy's clothes!

**luggage**

131

**Letter Mm**

**Directions:** Trace and write the letter Mm.

UPPERCASE  
M M M M M M M

lowercase  
m m m m m m m m

**Directions:** These pictures begin with the letter Mm.  
Color the pictures.

132

**Letter Mm**

You can help the mouse find the cheese.

**Directions:** Draw a green line to follow each M and m.

133

**Letter Mm**

**Directions:** Circle the M or m in these words:

man monkey Mario  
mask make Martin

**Directions:** Color the pictures that start with the sound of Mm.

134

**Letter Mm**

**Directions:** Draw a line from each Mm to a picture that begins with the sound of Mm. Color the pictures.

135

**Letter Nn**

**Directions:** Trace and write the letter Nn.

UPPERCASE  
N N N N N N N

lowercase  
n n n n n n n n

**Directions:** These pictures begin with the letter Nn.  
Color the pictures.

136



# Answer Key

**Letter Nn**

Can you find each N and n that is hidden in the room?

**Directions:** Color each N purple and each n orange. Then, color the rest of the room!

137

**Letter Nn**

**Directions:** Circle the N or n in these words:

Nothin net Nn  
n nest Nancy

**Directions:** Color the pictures that start with the sound of Nn.

138

**Letter Nn**

These words start with N or n.

**Directions:** Write a lowercase n on each line.

**Color** the pictures.

N is for nest.

N is for nifts.

N is for net.

139

**Letter Oo**

**Directions:** Trace and write the letter Oo.

UPPERCASE

lowercase

**Directions:** These pictures begin with the letter Oo.

**Color** the pictures.

140

**Letter Oo**

See what has 8 legs and lives in the ocean.

**Directions:** Color the spaces with Oo brown. Color the other spaces blue.

141

**Letter Oo**

**Directions:** Circle the O or o in these words:

Ovia Ovl Oobus  
Oce Ooly Owen

**Directions:** Color the pictures that start with the sound of Oo.

142



# Answer Key

**Letter Oo**

These words start with O or o.

**Directions:** Write a lowercase o on each line.

**Color** the pictures.

O is for **O**strich.

O is for **O**ven.

O is for **O**ctopus.

143

**Letter Pp**

**Directions:** Trace and write the letter Pp.

UPPERCASE

lowercase

**Directions:** These pictures begin with the letter Pp.

**Color** the pictures.

144

**Letter Pp**

**Directions:** Color each P or p on the pizza red. Then, color the rest of the pizza.

145

**Letter Pp**

**Directions:** Circle the P or p in these words:

pencil Paul pig  
party penny Patty

**Directions:** Color the pictures that start with the sound of Pp.

146

**Letter Pp**

**Directions:** If the picture begins with the sound of Pp, leave the space white. Color all of the other spaces red to find a popping good snack!

147

**Letter Qq**

**Directions:** Trace and write the letter Qq.

UPPERCASE

lowercase

**Directions:** These pictures begin with the letter Qq.

**Color** the pictures.

148



# Answer Key

**Letter Qq**

Look how quiet everything in the picture seems.

**Directions:** Can you find each Q and q? Color each Q blue and each q yellow.

149

**Letter Qq**

**Directions:** Circle the Q or q in these words:

Quincy    Quarter    Quilt  
Quit    Quinn    Quiet

**Directions:** Color the pictures that start with the sound of Qq.

150

**Letter Qq**

**Directions:** Color the squares with pictures that begin with the sound of Qq red. Color all of the other sections yellow.

151

**Letter Rr**

**Directions:** Trace and write the letter Rr.

UPPERCASE  
RRRRRRRRRR

lowercase  
rrrrrrrrrr

**Directions:** These pictures begin with the letter Rr.  
Color the pictures.

152

**Letter Rr**

**Directions:** Trace each R and r. Color each raindrop with R green. Color each raindrop with r blue. Use the same colors for the letters on the umbrella.

153

**Letter Rr**

**Directions:** Circle the R or r in these words:

Rain    Roses    Robert  
Rake    Rabbit    Renee

**Directions:** Color the pictures that start with the sound of Rr.

154





# Answer Key

**Letter Rr**

Help Rodeo Raccoon rope the Rs.

**Directions:** Circle each picture that begins with the sound of Rr. Color the picture with fun colors for Rodeo Raccoon!

155

**Letter Ss**

**Directions:** Trace and write the letter Ss.

UPPERCASE

lowercase

**Directions:** These pictures begin with the letter Ss.  
 Color the pictures.

156

**Letter Ss**

**Directions:** Trace each S and s. Color each bubble with S yellow. Color each bubble with s purple.

157

**Letter Ss**

**Directions:** Circle the S or s in these words:

Spin    Sea    Six  
 Sam    Sailboat    Side

**Directions:** Color the pictures that start with the sound of Ss.

158

**Letter Ss**

These words start with S or s.

**Directions:** Write a lowercase s on each line.  
 Color the pictures.

S is for     **S** aw.

S is for     **S** un.

S is for     **S** nake.

159

**Letter Tt**

**Directions:** Trace and write the letter Tt.

UPPERCASE

lowercase

**Directions:** These pictures begin with the letter Tt.  
 Color the pictures.

160



# Answer Key

**Letter Tt**

Do you like to play tic-tac-toe?

**Directions:** Color each T and t with the correct color.

**Draw** a line to win tic-tac-toe.

T = red  
t = green

T = blue  
t = yellow

T = purple  
t = orange

161

**Letter Tt**

**Directions:** Circle the T or t in these words:

Taylor    Table    Tiger  
Timothy    Tiro    Television

**Directions:** Color the pictures that start with the sound of Tt.

162

**Letter Tt**

**Directions:** Color the pictures that begin with the sound of Tt orange. Then, color the rest of the picture with bright colors.

163

**Letter Uu**

**Directions:** Trace and write the letter Uu.

UPPERCASE

lowercase

**Directions:** These pictures begin with the letter Uu.

**Color** the pictures.

164

**Letter Uu**

Find each hidden U and u.

**Directions:** Color each U purple. Color each u orange. Then, color the rest of the picture.

165

**Letter Uu**

**Directions:** Circle the U or u in these words:

Under    Unicorn    Unless  
Umbrella    Up    Use

**Directions:** The letter Uu can have more than one sound.

**Color** the pictures that start with the sound of Uu.

166



# Answer Key

**Letter Uu**

These words start with **U** or **u**.

**Directions:** Write **u** on each line.

**Color** the pictures.

U is for **U**nicorn.

U is for **U**p.

U is for **U**mbrella.

167

**Letter Vv**

**Directions:** Trace and write the letter **Vv**.

UPPERCASE

lowercase

**Directions:** These pictures begin with the letter **Vv**.

**Color** the pictures.

168

**Letter Vv**

**Directions:** Trace each **V** and **v**. Color each heart with **V** or **v** red. Draw a line from each **V** or **v** to one of the hearts on the left.

169

**Letter Vv**

**Directions:** Circle the **V** or **v** in these words:

Valerie    Violin    Vest  
Victor    Valentine    Van

**Directions:** Color the pictures that start with the sound of **Vv**.

170

**Letter Vv**

Help Vern Vampire vacuum.

**Directions:** Circle the pictures that begin with the sound of **Vv**. Color all the pictures.

171

**Letter Ww**

**Directions:** Trace and write the letter **Ww**.

UPPERCASE

lowercase

**Directions:** These pictures begin with the letter **Ww**.

**Color** the pictures.

172





# Answer Key

**Letter Xx**

These words start with X or x.

**Directions:** Write a lowercase x on each line.

**Color** the pictures.

X is for X-ray.

X is in EXIT.

X is for xylophone.

179

**Letter Yy**

**Directions:** Trace and write the letter Yy.

UPPERCASE

lowercase

**Directions:** These pictures begin with the letter Yy.

**Color** the pictures.

180

**Letter Yy**

Find each Y and y hidden in the yard.

**Directions:** Color each Y red and each y yellow.

**Color** the rest of the yard and make it fun!

181

**Letter Yy**

**Directions:** Circle the Y or y in these words:

Yarn Y-y-y-ard Yurt Y-yonne Y-y

**Directions:** Color the pictures that start with the sound of Yy.

182

**Letter Yy**

Make this yo-yo spin.

**Directions:** Color only the pictures that begin with the sound of Yy.

183

**Letter Zz**

**Directions:** Trace and write the letter Zz.

UPPERCASE

lowercase

**Directions:** These pictures begin with the letter Zz.

**Color** the pictures.

184



# Answer Key

**Letter Zz**

Take a trip through the zoo.

Directions: Color only the pictures that begin with the sound of Zz.

185

**Letter Zz**

Directions: Circle the Z or z in these words:

Zipper Zebra Zig-zag  
Zelda Zoro Zoo

Directions: Color the pictures that start with the sound of Zz.

186

**Letter Zz**

These words start with Z or z.

Directions: Write a lowercase z on each line.

Color the pictures.

Z is for Zipper.

Z is for zig-zag.

Z is for Zebra.

187

**Review Letters Aa-Zz**

Directions: Draw lines to match the UPPER and lowercase letters that go together.

188

**Review Letters Aa-Zz**

Directions: Draw lines to match the UPPER and lowercase letters that go together.

189

**Review Letters Aa-Zz**

Directions: Practice writing the letters Aa-Uu by tracing the UPPER and lowercase letters below.

190



# Answer Key

**Review Letters Aa-Zz**

Directions: Practice writing the letters Mm-Zz by tracing the UPPER and lowercase letters below.

Mm Nn Oo  
Pp Qq Rr  
Ss Tt Uu  
Vv Ww Xx  
Yy Zz

191

**Review Letters A-Z**

Directions: Grandparents are fun to visit. Draw a line from A-Z to show the way to the grandparents' house.

192

**Review Letters a-z**

Directions: Connect the dots as you say the alphabet, starting with the letter a. Color the picture.

193

**Stop Making Sense!**

Look at the picture. A lot of silly things are happening!

Directions: Circle all of the things that do **not** make sense.

194

**Ben's New Sister**

Directions: Ben is going to see his new baby sister for the first time! Ben and his dad are at the hospital looking at all the sleeping babies. Use the clues to find out which baby is Ben's new sister. Then, circle your choice.

Ben's sister is not bald.  
Ben's sister has a yellow blanket.  
Ben's sister has dark hair.

195



# Answer Key

**Color It In!**

Directions: Color the 1 picture in each row that both words describe.

**soft and cold**

**tall and large**

**hot and round**

**shiny and hard**

196

**Color It In Again!**

Directions: Color the 1 picture in each row that both words describe.

**square and hard**

**sticky and pink**

**smooth and cold**

**wet and large**

197

**Find the Right Picture**

Directions: Which picture goes with the sentence? Circle the correct picture.

The 3 little pigs had a picnic in the tree to escape from the big bad wolf.

198

**Find the Right Picture**

Directions: Which picture goes with the sentence? Circle the correct picture.

Marilyn and Mindy went on a Ferris wheel ride with their parents.

199





# Answer Key

**Which Picture Is Missing?**

**Directions:** Look at the pictures below. There is a picture missing.

**Circle** the missing picture.

200

**Which Picture Is Missing?**

**Directions:** Look at the pictures below. There is a picture missing.

**Circle** the missing picture.

201

**Puppy Needs**

Marcy and her dad want to build a doghouse for their new puppy.

**Directions:** Draw X on the things they will **not** need. Then, draw pictures of some other things they might need.

**Pictures will vary.**

202

**Super Ice-Cream Sundaes!**

Janet and her mom want to make ice-cream sundaes.

**Directions:** Draw X on the things they will **not** need. Then, draw pictures of some other things they might need.

**Pictures will vary.**

203



# Answer Key

**What Will Happen Next?**



**Directions:** Look at the picture above. Now, circle the picture below that shows what happens next.



204

**What's Next?**



**Directions:** Look at the picture above. Now, circle the picture below that shows what happens next.



205

**Tim's Turtle**

**Directions:** Help Tim pick out a turtle at the pet shop.  
 Tim does **not** want a turtle with circles on its back.  
 Tim does **not** want a green turtle.  
 Tim does **not** want a turtle with triangles on its back.  
**Circle** the turtle that Tim should pick.

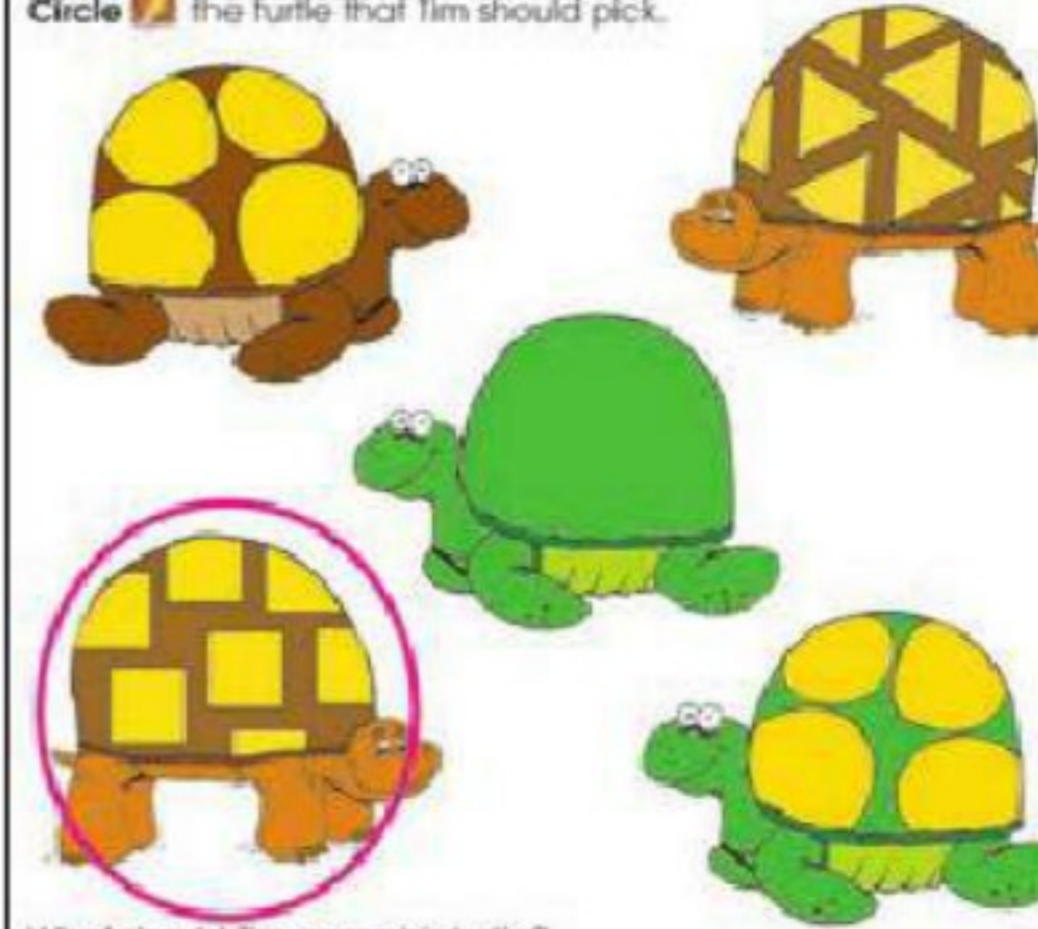

What should Tim name his turtle?

206

**I'm Hungry!**

**Directions:** Draw a line to match each animal to the food it likes to eat.

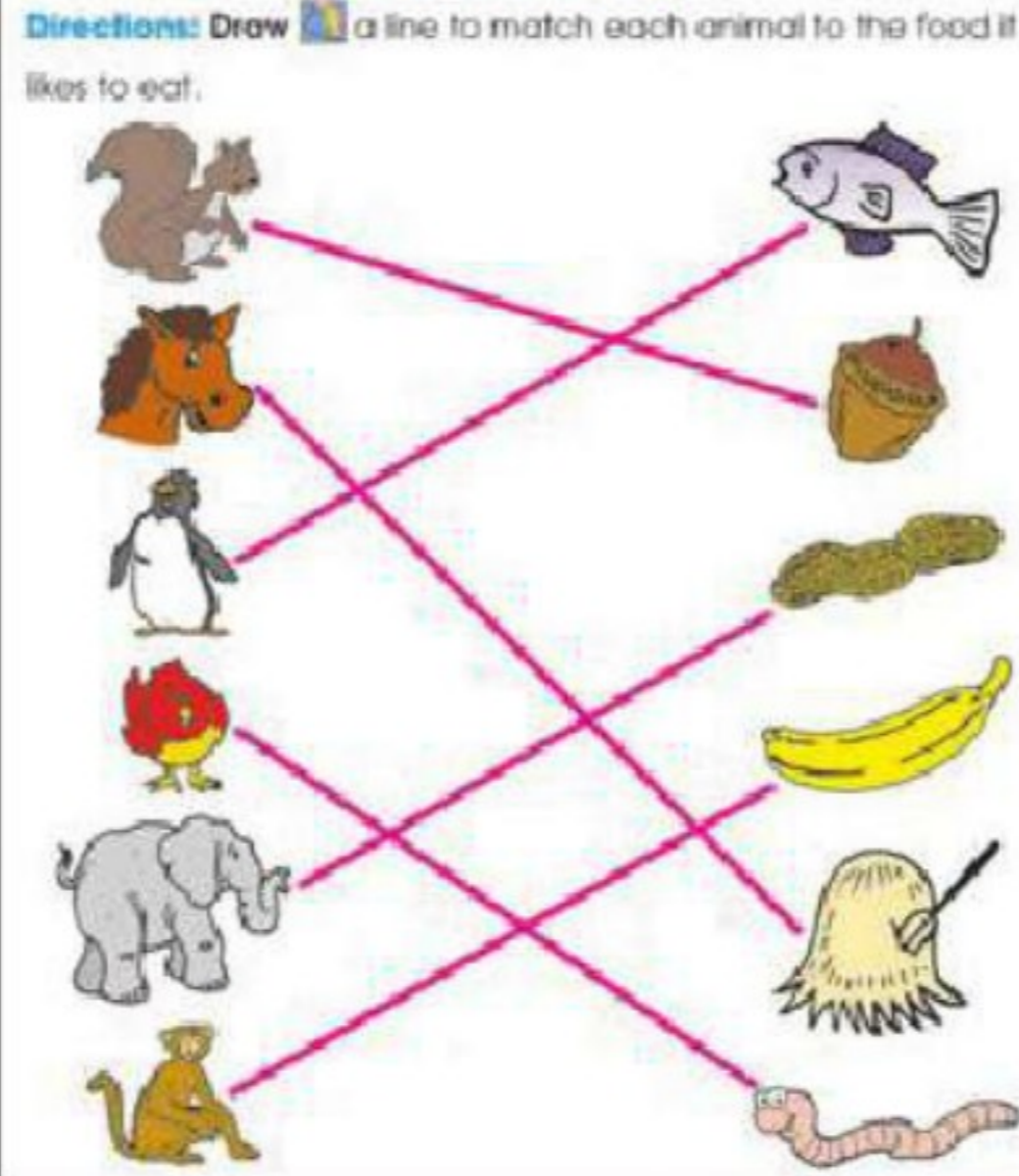

213